

STOP&GO connected kit and automatic resetting



4 149 54



4 062 88

Pack	Cat.Nos	Connected STOP&GO (remote control resetting)	
1	4 149 54	Control voltage 230 V~	No. of modules 4

For remotely switching (via a smartphone or tablet) 1 module per pole RCCBs and RCBOs up to 63 A. Examples of use:

- In the event of unwanted tripping (generated by temporarily electrical disturbances or other external events) the Connected STOP&GO will do an automatic checking of the installation. If no permanent fault is detected: it will send a message on the smartphone or tablet of the user in order to get an authorization to switch on the associated device.
- In case of permanent fault: the user will be informed about it without having the possibility to remotely switch on the power.
- Needs a permanent internet connection via a Wi-Fi modem/router (powered by an UPS) in order to send messages to the user and allow him to remotely control the circuit.
- In a normal situation, to remotely switch ON a circuit (like the electrical heating in a holiday house). Can take one control auxiliary and one signalling auxiliary. The signalling auxiliary must be placed between the STOP&GO and the control auxiliary. No tool required for assembling.

Kit comprising:

- 1 Connected STOP&GO (non-automatic)
- 1 IP gateway (Wi-Fi connection)
- 1 power supply module, input voltage 230 V~/ output voltage 12 V=
- 2 communication cables

Pack	Cat.Nos	STOP&GO automatic resetting	
1	4 062 88	Control voltage 230 V~	No. of modules 2
1	4 062 89	Control voltage 230 V~	No. of modules 2

For automatic resetting of 1 module per pole RCCBs and RCBOs up to 63 A. STOP&GO is used in the event of unwanted tripping generated by temporarily electrical disturbances or other external events. Can take one control auxiliary and one signalling auxiliary. The signalling auxiliary must be placed between the STOP&GO and the control auxiliary. No tool required for assembling

Automatic resetting function

Automatic resetting + periodic self-test function

Manual supply inverter DX³ and accessories



4 063 14

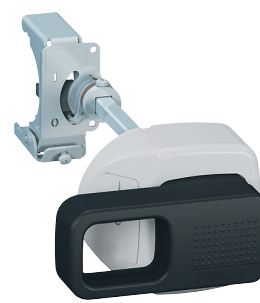

4 063 19

Pack	Cat.Nos	Manual supply inverter (MSI)	
1	4 063 14	For manually switching between the mains and an alternative power supply. Allow to restore power on pre-designated and/or critical circuits in case of a power failure of the main supply.	
1	4 063 15	For 2P 2-module devices	
1	4 063 16	For 3P 3-module devices	
		For 4P 4-module devices	
		Front external rotary handles	
1	4 063 19	Allow the manual control (open/close) of a modular device without opening the enclosure	
1	4 063 20	For all DX ³ , TX ³ and RX ³ devices from 2P upwards	
		Supplied with bracket, connection rod, handle, self-adhesive drilling template and connection accessories	
		Installation principle - see e-catalogue	
		Black handle	
		Yellow and red handle	
		Wiring management accessories	
		Insulating shields	
1	4 063 05	For 1 module per pole MCBs	
		For separation between the terminals of the MCB, when using high cross section cables	
		Spacing unit with feedthrough	
10	4 063 07	0.5 module	
		Allows cables to run between two modular devices and creates an air channel in order to limit temperature rise	
		Terminals for aluminium cables	
1	4 063 10	For 1 and 1.5 module/pole MCBs up to 63 A	
1	4 063 11	For 1.5 module/pole MCBs and remote trip isolating switches from 80 A to 125 A	
		Safety and maintenance accessories	
		Sealable screw covers	
2	4 063 04	For 1 module per pole MCBs (set of 4)	
1	4 063 12	For 1.5 module per pole MCBs (set of 4)	
		Terminal shield	
1	4 063 06	For 1.5 module/pole MCBs (set of 2)	
		Padlocking	
		To lock the handle of a modular device during maintenance	
1	0 227 97	Large padlock, Ø6 mm, 50 mm length	
		Supplied with two keys and labels	
3	4 063 13	Small padlock, Ø5 mm	
2	4 063 03	Support for one padlock (for small or large model)	
		For locking the handle of the modular devices (MCBs, RCCBs, RCBOs or isolating switches) in OFF position	

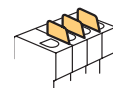

Dimensions of din-rail equipment

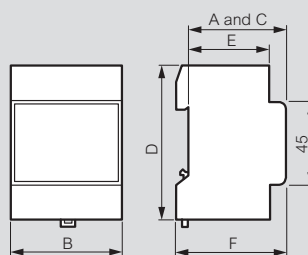
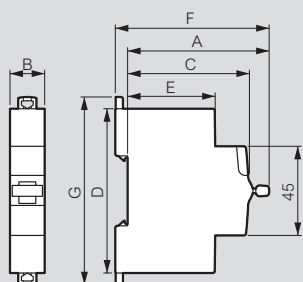

Product	A		B				C	D	E	F	G
	1P	1P+ N	2P	3P	4P						
RX³ MCBs	71.7	17.7	35.4	35.4	53.1	70.8	61	83	44	77.8	88.9
RX³ RCCBs	71.7			35.6		71.2	61	83	44	77.8	88.9
TX³ MCBs	71.7	17.7	35.4	35.4	53.1	70.8	61	83	44	77.8	88.9
TX³ RCCBs	71.7			35.6		71.2	61	83	44	77.8	88.9
Isolating switches DX³	71.7	17.8		17.8/ 35.4	35.6/ 53.1	70.8	61	83	44	77.8	94.8
Remote trip head isolating switches DX³ up to 63A - 1 mod/pole	71.7			35.4	53.1	70.8	61	83	44	77.9	94.8
Remote trip head isolating switches DX³ 100/125A - 1.5 mod/pole	73				80.1	106.8	61	96	47	79	104.3
DX³ RCCBs	71.7			35.6		71.2	61	83	44	77.8	94.8
1P DX³ RCBOs (up to 45A)	68	17.7					60	115	48	74	126.8
1P+N DX³ RCBOs (up to 40A) & 4P (up to 32A)	71.7		35.6			71.2	61	83	44	77.8	94.8
2P & 4P DX³ RCBOs (40A to 63A)	72			71.2		124.6	61	96	44	78.2	107.8
1P+N DX³ MCBs 1 mod	71.7		17.8				61	83	44	77.8	94.8
DX³ MCBs - 1 mod/pole	71.7	17.7	35.4	35.4	53.1	70.8	61	83	44	77.8	94.8
DX³ MCBs - 1,5 mod/pole	73.1	26.7		53.4	80.1	106.8	61	100	47	79	104.3
DX³ add-on modules up to 63A - 1 mod/pole	72			35.6	53.4	53.4	61	96	44	78.2	107.8
DX³ add-on modules up to 63A - 1.5 mod/pole	72			35.6	53.4	53.4	61	96	47	78.2	116.7
DX³ add-on modules 80 to 125A - 1.5 mod/pole	72			71.2	106.8	106.8	61	114	47	78.2	129
DX³ auxiliaries	71.5			8.8 / 17.7			61	83	44	77.7	84.5
DX³ remote control	74.3			17.7 / 35.4			61	83	44	80.5	98.8
DX³ Stop&Go automatic resetting	74.3			35.4			61	83	44	80.5	113.7
Change-over switches	68	17.7		35.6			60	83	44	74	94
CX³ latching relays	64	17.8		17.8	35.6	35.6	61	84.5	44	70.2	94.8
CX³ contactors up to 25A	66.3/ 61	17.8		17.8	35.6	35.6	61	84.5	44	72.6/ 67.3	94.8
CX³ contactors 40A & 63A	62			35.6	53.4	53.4	60	83	44	68	94
Auxiliaries for CX³ contactors and latching relays	61			9/17.8			61	84.5	44	67	84.5
Push-buttons / control switches	68			17.7			60	83	44	74	94
Indicators	68			17.7			60	83	44	69	94
Bells and buzzers	60			17.7			60	76	44	66	85
Light sensitive switches											
Cat.Nos 0 037 21, 4 126 23	60			35.6			60	85	37.5	66	70
Socket outlets	60			44.5			60	83	44	66	92
Time delay relays	60			17.7			60	83	44	66	94
Remote control dimmers											
Cat.No 0 036 58	60			36			60	83	44	66	94
Cat.No 0 036 60	60			72			60	83	44	66	94
Cat.No 0 036 71	60			108			60	83	44	66	94

Description	A	B	C	D	E	F
Programmable time switches						
0 037 05	60	17.8	60	83	44	66
4 127 80/90/94	60	17.8	60	83	44	66
4 127 95, 4 128 12/13	60	53	60	83	44	66
4 126 31/33/41	60	35.6	60	83	44	66
4 126 54/57	60	35.6	60	83	44	66
0 047 70	60	90	60	83	44	66
Transformers and power supplies						
0 042 10/30/31	60	72	60	83	44	66
4 130 91	60	35.8	60	83.5	44	66
4 130 92/93/96	60	71.5	60	83.5	44	66
4 130 98	60	89	60	94	44	66
0 047 91/92	60	105	60	95	44	66
4 131 05/06/07/08	60	89	60	95	44	66
0 047 93	60	70	60	95	44	66
Residual current relay						
0 260 88	60	35.5	60	89	44	66

STOP&GO automatic resetting for DX³

Manual changeover switches for DX³

Temporarily electrical disturbances and other external events can cause unwanted tripping of different devices protecting electrical installation

STOP&GO verifies automatically the state of the installation, before resetting and launches a visual and audible alarm signal in case of permanent fault detection (short-circuit or residual current)

After verifying the state of the installation, STOP&GO automatic resets the associated protection device in order to immediately re-establish power supply and avoid unwanted consequences

STOP&GO does not protect the installation against lightning strikes
For an efficient protection against lightning, use voltage surge protectors

The Autotest version is specially suitable for installations equipped with residual current protection devices (RCD's and RCBOs)
STOP&GO periodically does an automatic test of the functioning of residual current protection devices. The manual test is no longer needed

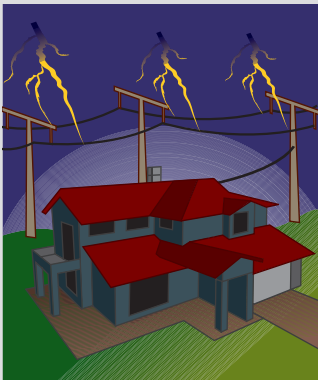

Installation without STOP&GO

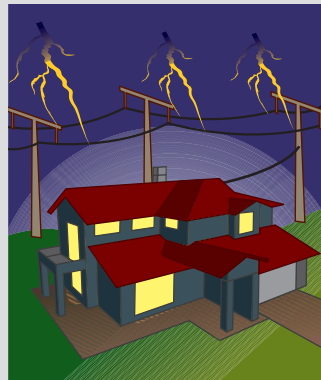

Installation with STOP&GO

Mains fault due to temporarily electrical disturbances
Electrical devices are not powered anymore

STOP&GO automatic resets the associated protection device in order to immediately re-establish power supply

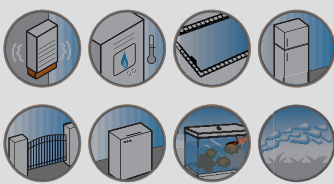

1- The power is on the general network
The MCB behind the window, connected to the generator is on the OFF position

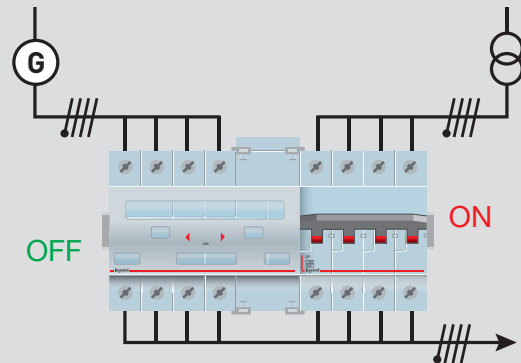

2- Switch OFF the main MCB

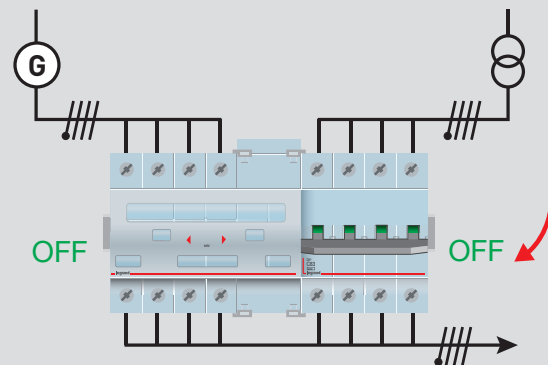

3- Slide the window in order to change the power supply

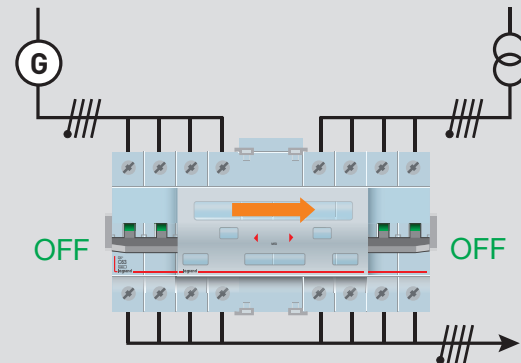

4- Switch ON the MCB connected to the generator

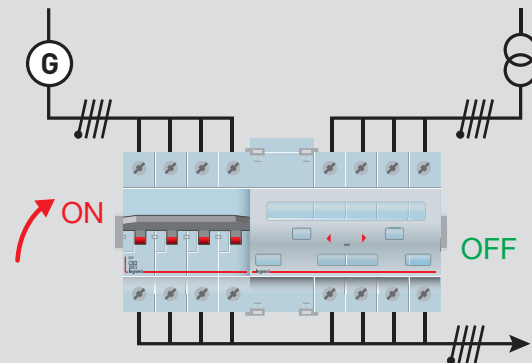

Front external rotary handles

■ Example of mounting on a DX³ MCB

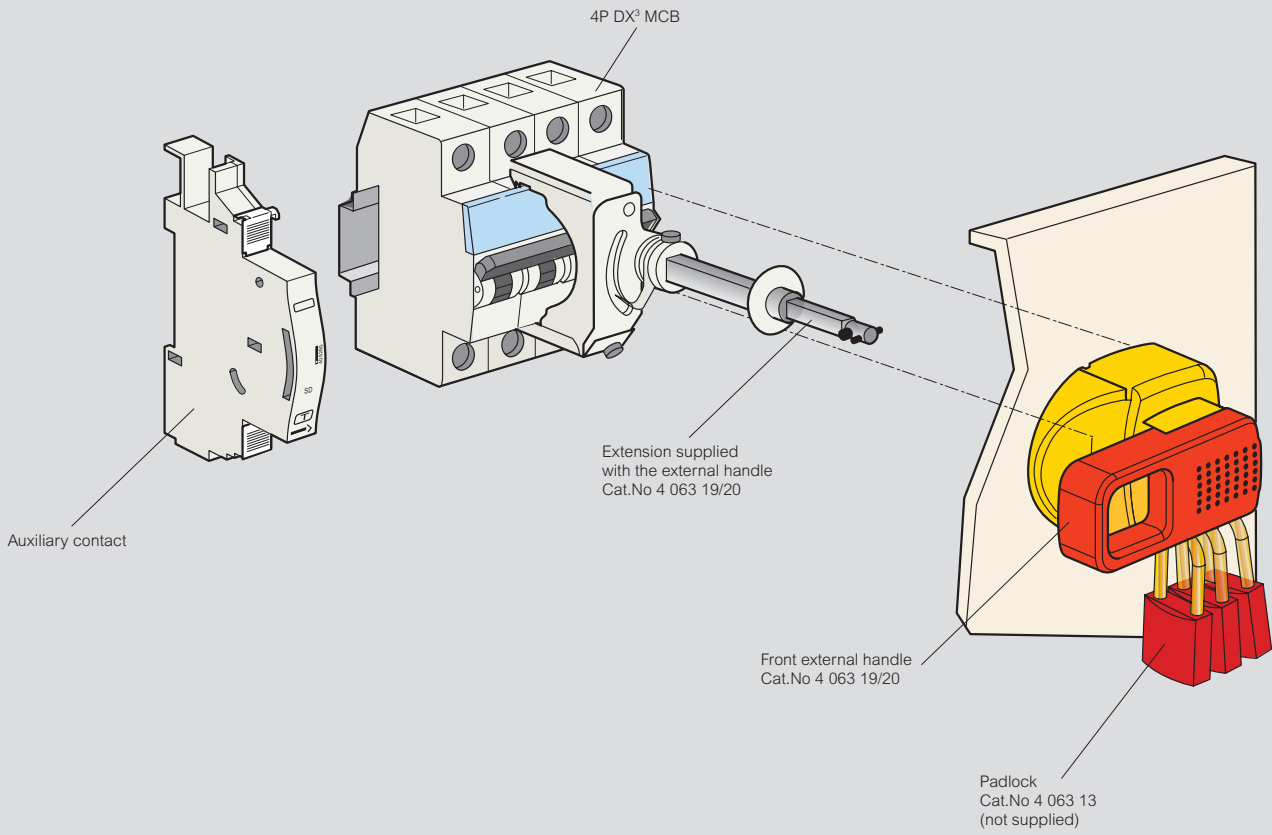

STOP & GO automatic resetting

Cat. N°(s) : 4 062 88 / 4 062 89



CONTENTS	PAGE
1. Description - Use	1
2. Product range	1
3. Overall dimensions	1
4. Preparation - Connection	1
5. General characteristics	4
6. Conformities and approvals	5
7. Auxiliaries and accessories	6

1. DESCRIPTION - USE

STOP & GO motor driven unit is an automatic resetting device for MCB's, RCBO's (P+N or 2P) and RCCB's (2P).
 STOP & GO automatic resetting main functions are:

- . In case of tripping due to earth leakage or short circuit, it detects the presence of an insulation fault in the system before to reset.
- . In case of transient fault, it automatically resets the electrical circuit.
- . In case of permanent fault, (earth leakage or short circuit), it keeps the circuit open and notifies the user by a visual signal and, if necessary, by an acoustic signal (by an integrated contact)
- . These functions allow the continuity of operation of the involved circuits.
- . Cat. n° 4 062 89 is fitted with a self-test function that allows to test automatically every 56 days (hour and day of test are programmable) that the associated residual current device operates properly.

Technology :

- . DC electric motor with permanent magnets

2. PRODUCT RANGE

Cat. N° 4 062 88:

- . It automatically resets the associated device (P+N or 2P) in case of tripping after a transient fault.
- . It checks the status of the installation before to reset.
- . It reports any permanent fault (earth leakage or short circuit).

Cat. N° 4 062 89:

- . In addition to the same functions as cat. n° 4062 88, it allows an automatic periodic test of the associated 30 mA residual current device.

Width = 2 modules (35,4 mm)

Rated Voltage & Frequency:

- . 230 V ~ 50 / 60 Hz with standard tolerances.

Operating voltages:

- . Minimum (0,85 x Un) : 195,5 V
- . Maximum (1,1 x Un) : 253 V

3. OVERALL DIMENSIONS

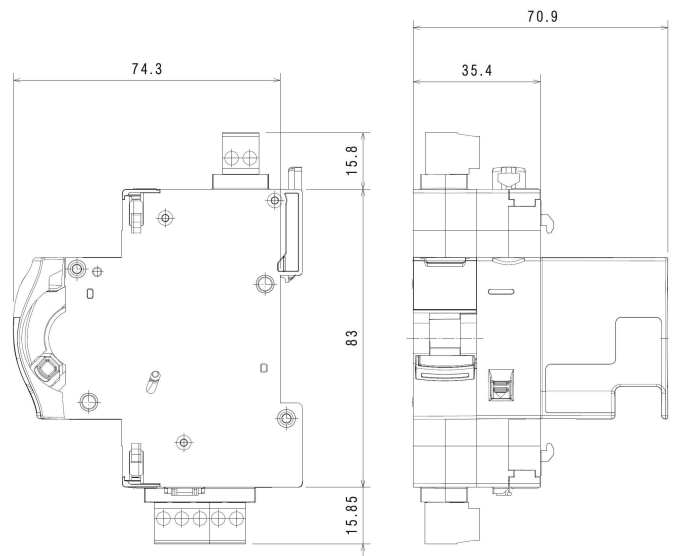

4. PREPARATION - CONNECTION

Fixing:

- . On symmetric rail EN/IEC 60715 or DIN 35.

Operating positions:

- . Vertical, Horizontal, backwards, on the side

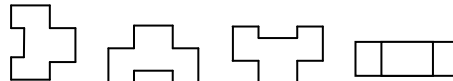

Supply:

- . Supply Phase and Neutral from the top on the extractable connector
- . It is compulsory to connect Phase and Neutral downstream of the associated device and the protection conductor to the connector at the bottom of this device. Stop & Go will not work correctly if the protection conductor is not connected.

List of possible associations:

- . 2P RCCBs
- . 2P RCBOs (2 poles protected or P+N, 1 pole protected)
- . 2P MCBs (2 poles protected or P+N, 1 pole protected)

4. PREPARATION - CONNECTION (continued):

Association:

- . To be fitted to the left of MCB's DX³ ≤ 10 000A (P+N, 1P, 2P - 1 module per pole wide), RCCB's DX³ 2P and RCBO's DX³ ≤ 10 000A (P+N et 2P ≤ 63A)
- . No tool required. Clipped to the associated device by mean of plastic clamps.

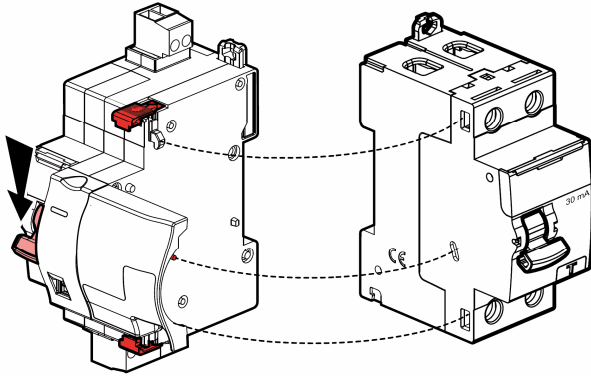

Wiring diagram:

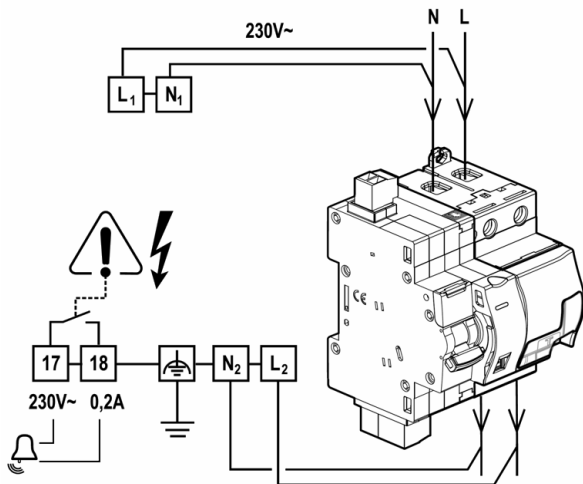

Protection of STOP&GO:

- . It is not necessary to install specific protections upstream of the Stop & Go because it is self-protected

Connection:

- . Terminals protected against accidental contact (IP20, wired device).

Depth of terminals :

- . 10 mm.

Connectable section:

	Copper cables	
	Without ferrule	With ferrule
Rigid cable	1 x 2,5mm ² 2 x 1,5mm ²	-
Flexible cable	1 x 2,5mm ² 2 x 1,5mm ²	1 x 2,5mm ² 2 x 1,5mm ²

4. PREPARATION - CONNECTION (continued):

Stripping length recommended:

- . 7 mm.

Screw head:

- . Slotted, diameter 3.5 mm.

Recommended tightening torque:

- . 0.4±0.5 Nm.

Tools required:

- . For the terminals: flat screwdriver 3.5 mm.
- . For fixing: flat screwdriver 5.5 mm (6 mm maximum).

Lockout:

- . By the sliding front face.
 - Sliding front face downward: the associated device goes into OFF position and manual or automatic closing operations are disabled.
 - Sliding front face upward: the device is operating.
- . Lockout by padlock Φ4mm only when the sliding front face is down. Then mechanical and electrical controls are not possible.

Display of the device status and the status of the contacts of the associated device:

- . By handle mark:
 - "O-Off" white on a green background = device switched-off and contacts opened.
 - "I-On" white on a red background = device powered-on and contacts closed.

Device handle status:

- . The handle of the Stop & Go automatic resetting module, consists of two parts:

- an "isolating" handle
- a "power" handle

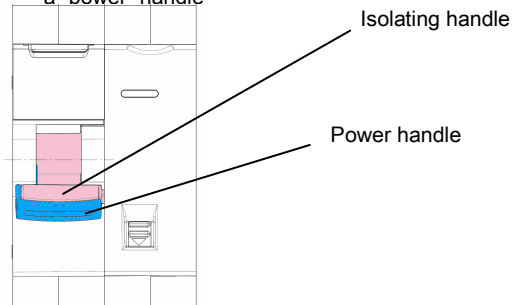

Operation sequences:

- Normal operation: both handle upward.

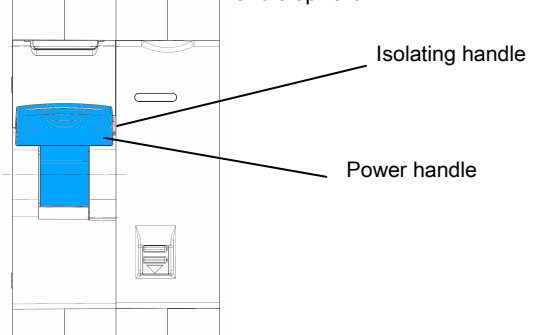

4. PREPARATION - CONNECTION (continued):

- In case of an unwanted tripping of the associated device and during the verification of the state of the electric circuit:

The power handle is down.

The isolating handle is up.

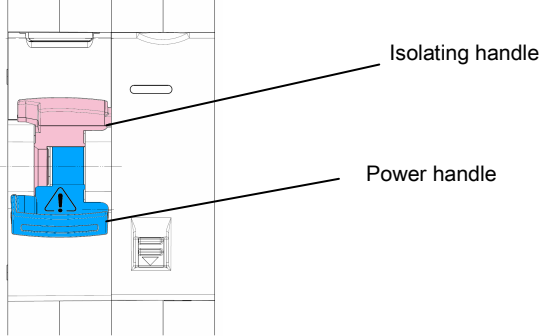

- If the Stop & Go detects a permanent fault after a tripping, the isolating handle goes down

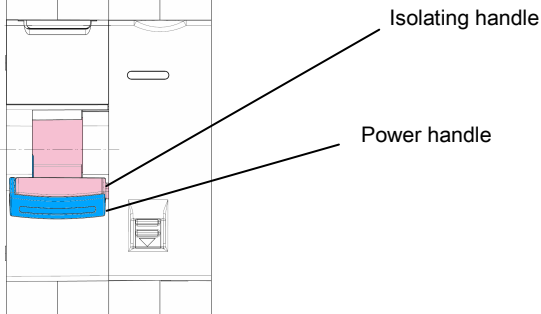

- If the Stop & Go doesn't detect a permanent fault, it returns to normal operation (reset of the associated device): both handle are upward.

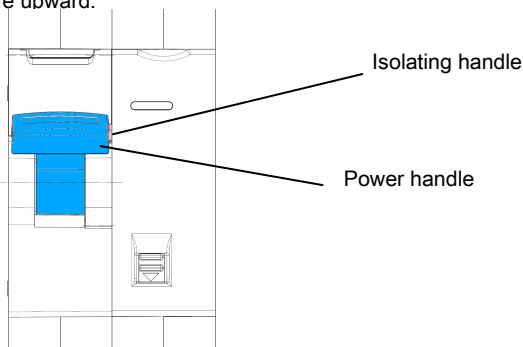

WARNING : the stop & go makes only one attempt of resetting.

Time of a re-setting cycle:

. < 2 sec

Tripping by the test button of the associated residual current device:

. In auto mode, when tripping the associated device by the test button, if the test button has been pushed more than 1 second, the Stop & Go unit will reset the associated device then switch it off again. It will be necessary to manually reset the Stop & Go.

4. PREPARATION - CONNECTION (continued):

Resetting by the Stop & Go handle:

. When the permanent fault has disappeared, the resetting of the Stop & Go and of the associated device is carried out by the Stop & Go handle (isolating and power handles together)

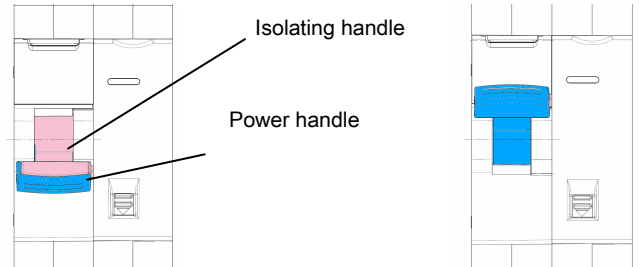

Selector AUTO / MAN:

. The selector enables and disables the automatic remote control.

. Positions:

- AUTO: possibility to automatically or manually control tripping and re-setting.
- MAN: manual control only by the handle of the Stop & Go (isolating and power handles together)

. Signalling by LED:

- Green fixed: associated device "power on" and "Stop & Go" in AUTO mode.
- Green flashing: "Stop & Go" in MAN mode.

Signalling:

. Signalling by LED:

- Green fixed: associated device "power on" and "Stop & Go" in AUTO mode. Automatic resetting activated (and self-test activated for cat. n° 4 062 89).
- Green flashing: "Stop & Go" in MAN mode.
- Red flashing: waiting for reset.
- Red fixed: the device has tripped on fault (overload, short-circuit, residual current fault) or by control auxiliary.
- Sliding front face downward: LED switched-off.
- Yellow fixed (cat. n° 4 062 89 only): self-test function has detected a malfunction of the associated differential device.

Self-test programming (cat. n° 4 062 89):

. After having connected cat. N° 4 068 89 to 230 V ~ network, put the handle on ON position, switch the selector from "AUTO" position to "MAN" position then again to "AUTO" position.

. The first automatic test of the residual current detection is carried out instantaneously. The next test will be carried out 56 days and 8 hours after the first test and this test will be shift during the night. Then the next test will occur every 56 days (8 weeks).

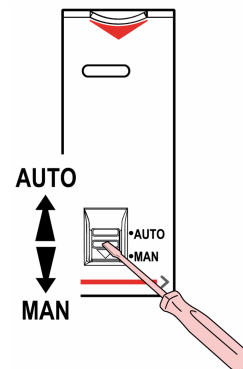

5. GENERAL CHARACTERISTICS

Front side marking:

. By permanent pad printing

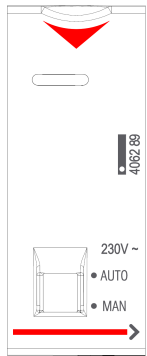

Lateral side marking:

. By laser.

left side

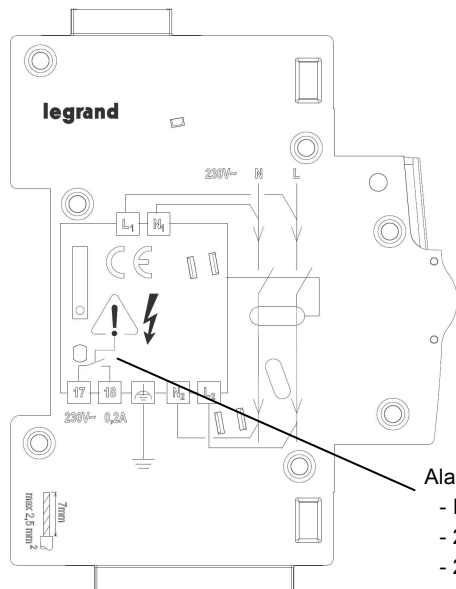

Alarm contact:
 - IEC/EN 60950
 - 230V~, 0,2A
 - 24 / 48V, 1A

right side

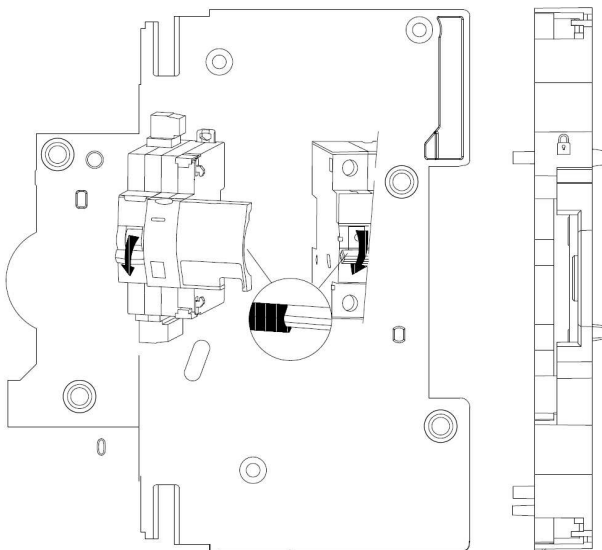

5. GENERAL CHARACTERISTICS (continued)

Characteristics of the fault detection:

- Rd (non operating rated resistance between the live parts and the earth) 225kΩ
- Rd0 (operating rated resistance between the live parts and the earth) 375kΩ
- Rcc (non operating rated resistance between the live parts) 0,75Ω
- Rcc0 (operating rated resistance between the live parts) 1,25Ω
- The Stop & Go device can be used in TT and TN earth systems

Pulse rated voltage:

. Uimp = 4 kV

Insulation rated voltage:

. Ui = 500 V

Pollution degree :

. 2 according to IEC/EN 60898-1.

Dielectric strength:

. 2500 V

Mechanical endurance:

. 20000 operations.

Electrical endurance:

. In accordance with the requirements of the standards of the associated protection device.

Enclosure material:

- . 20% glass-fiber reinforced polycarbonate
- . Characteristics of this material: self extinguishing, heat and fire resistant according to EN 60898-1, glow-wire test at 960°C for external parts made of insulating material necessary to retain in position current-carrying parts and parts of protective circuit (650°C for all other external parts made of insulating material).

Average weight per pole:

. 0.174 kg.

Volume when packed :

. 1.20 dm³.

Ambient operating temperature:

. Min. = - 5 °C / Max. = + 60 °C.

Ambient storage temperature:

. Min. = - 25 °C / Max. = + 60 °C.

Protection class:

- . Protection index of terminals against solid and liquid bodies: IP 20 (according to IEC 529, EN 60529 et NF C 20-010).
- . Protection index of the case against solid and liquid bodies: IP 40 (according to IEC 529, EN 60529 et NF C 20-010).

5. GENERAL CHARACTERISTICS *(continued)*

Resistance to sinusoidal vibrations:

- . According to IEC 60068-2-6.
- . Axis : x, y, z.
- . Frequency range: 5÷100 Hz ; duration 90 min.
- . Displacement (5÷13.2 Hz) : 1mm
- . Acceleration (13.2÷100 Hz) : 0.7g (g=9.81 m/s²).

Maximum power consumption:

- . <20VA rms (<80VA peak) during resetting

Standby power consumption:

- . <1,5VA

Recognition:

- . Labelling of the circuits by label in the "label holder" on the front-side of the device.

6. CONFORMITIES AND APPROVALS

Compliance with standards:

- . CEE guidelines : 73/23/CEE + 93/68/CEE
- . IEC / EN 50557: device for automatic reset of MCB's, RCBO's, RCCB's for household and similar purposes.
- . Electromagnetic compatibility: EN 61543
- . Legrand devices can be used under the conditions of use as defined by IEC / EN 60947.

7. AUXILIARIES AND ACCESSORIES

Signalling auxiliaries:

- . Auxiliary contact (½ module – cat n° 4 062 58).
- . Fault signalling changeover switch (½ module – cat n° 4 062 60).
- . Auxiliary contact modifiable in default signal (½ module – cat n° 4 062 62).
- . Auxiliary contact + fault signalling switch - can be modified to 2 auxiliary contacts (1 module - cat n° 4 062 66).

Control auxiliaries:

- . It is forbidden to associate control auxiliaries (cat. n° 4 062 7x / 8x) to motor driven control module with integrated automatic resetting.

Possible combinations with signalling auxiliaries:

- . Auxiliaries are clipped on the left side of the Stop & Go unit
- . Two signalling auxiliaries max. (cat. n° 4 062 58 / 60 / 62 / 66).
- . If two signalling auxiliaries are associated to a same motor driven control unit, the 1 module wide control auxiliary (cat n° 4 062 66 / 78 / 82 / 84) must be located to the left of the ½ module wide auxiliary (cat. n° 4 062 58 / 60 / 62).

			4062.. 88 / 89	
		4062.. 58 / 60 / 62 / 66	4062.. 88 / 89	
	4062.. 58 / 60 / 62	4062.. 58 / 60 / 62	4062.. 88 / 89	
	4062.. 58 / 60 / 62 / 66	4062 66		

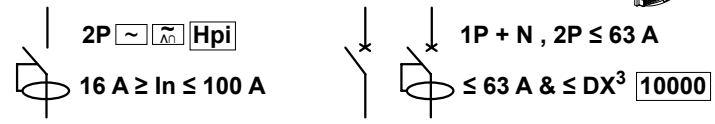
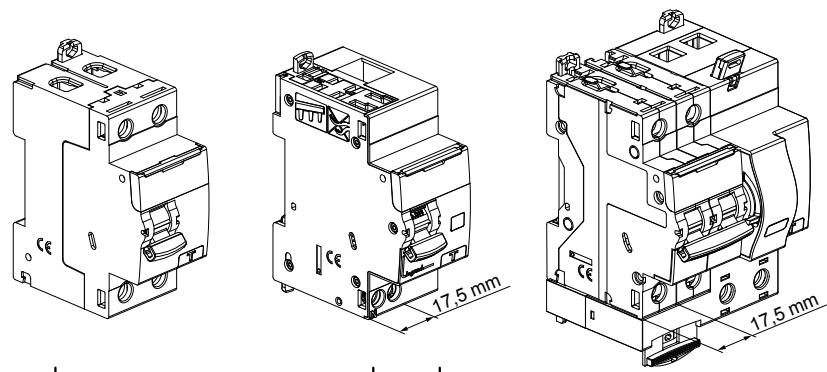
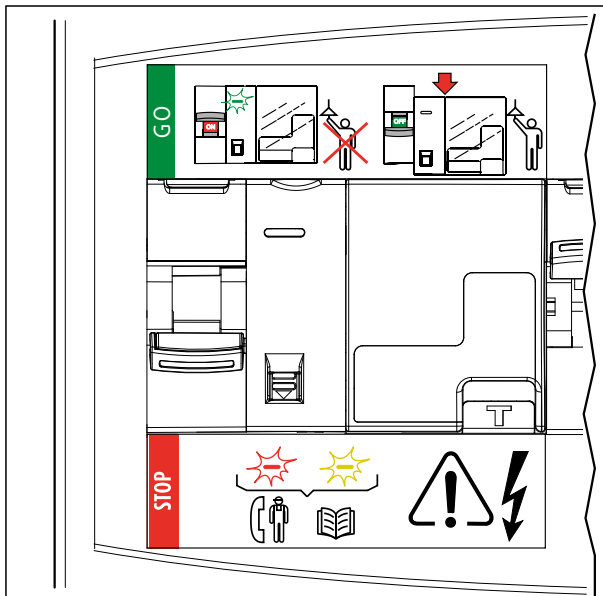
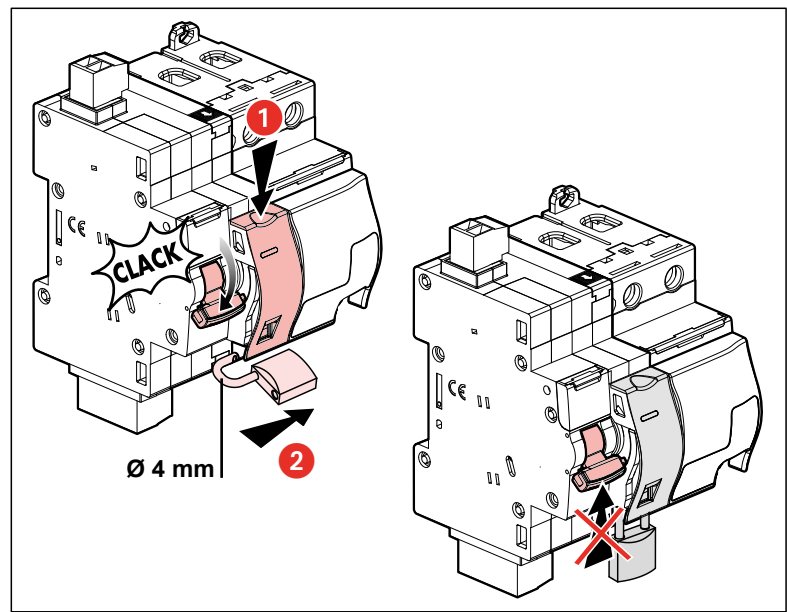
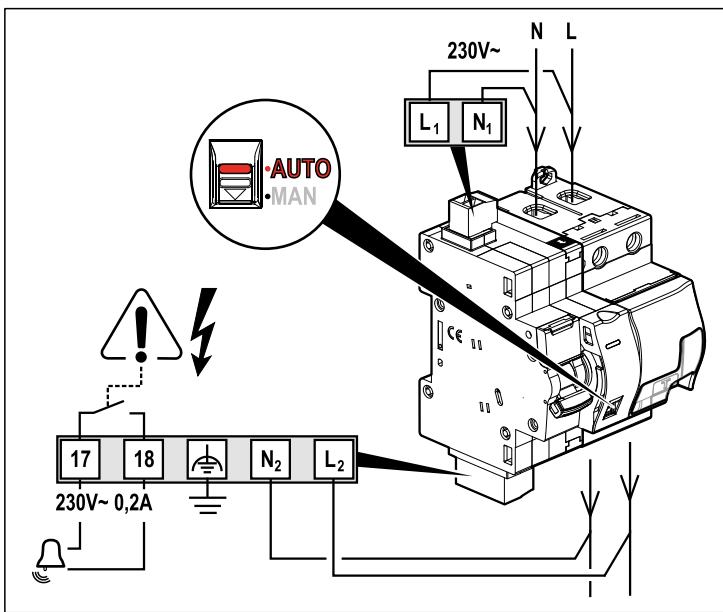
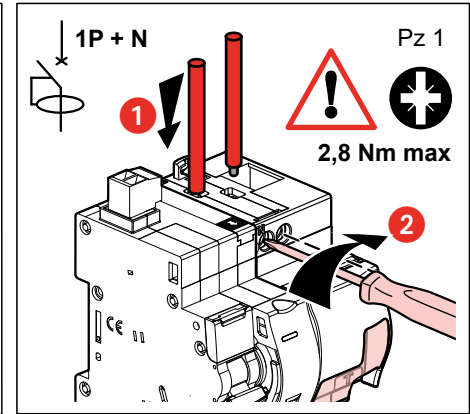
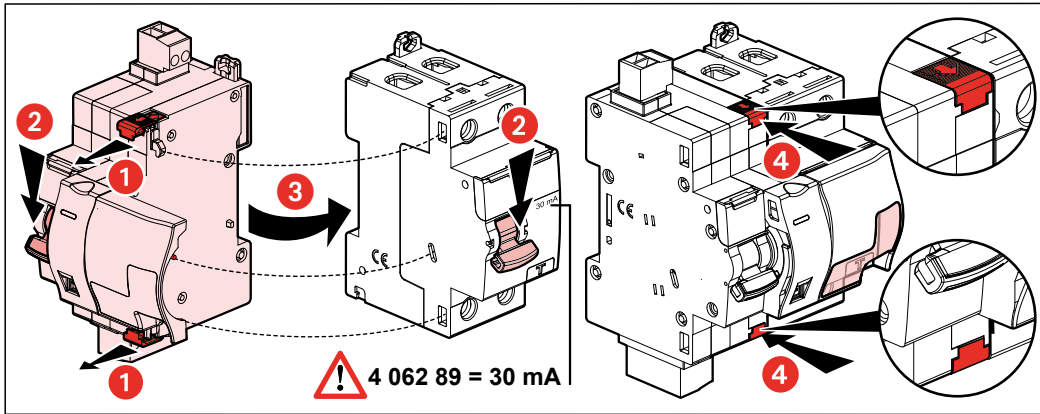
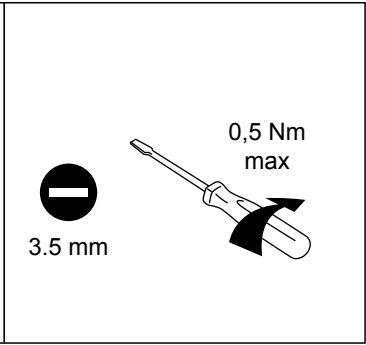
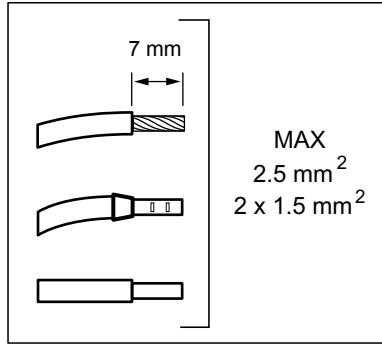
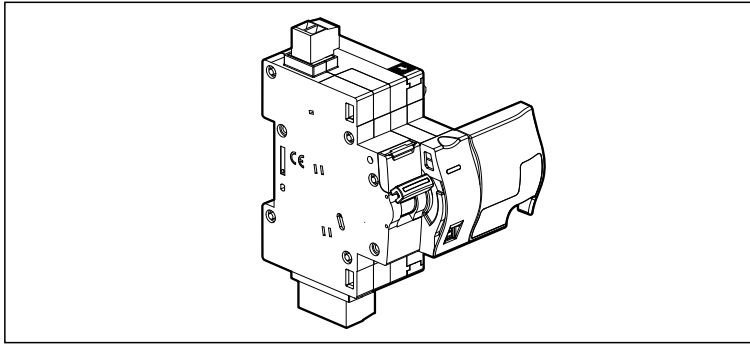



Autotest

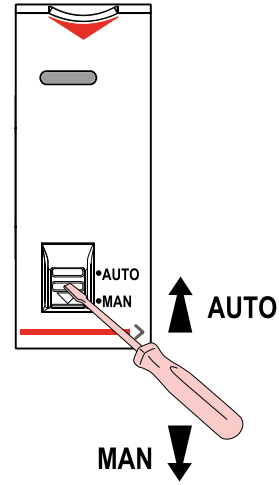
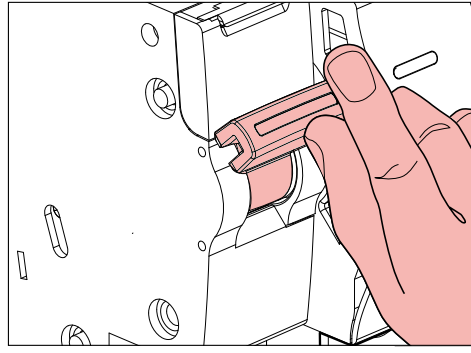

• Programmation:

- 1) Après avoir mis sous tension la référence 4 062 89, mettre la manette en position ON, passer le sélecteur de la position "AUTO" à la position "MAN" et le remonter en position "AUTO".
- 2) Le premier test automatique de la fonction différentielle est instantané. Le test suivant se réalisera 56 jours et 8 heures après ce premier test et permettra de décaler ce test pendant la nuit. Les tests suivants auront lieu tous les 56 jours (8 semaines).

• Programmering:

- 1) Na het onder spanning zetten van de referentie 4 062 89, de handgreep in de positie ON plaatsen, de keuzeschakelaar van de positie "AUTO" naar de positie "MAN" zetten en nadien deze opnieuw in de positie "AUTO" brengen.
- 2) De eerste automatische test van de differentieelfunctie gebeurt onmiddellijk. De volgende test vindt plaats 56 dagen en 8 uur na deze eerste test en laat toe om deze test uit te stellen tot tijdens de nacht. De volgende tests zullen plaats vinden om de 56 dagen (8 weken).

• Programming:

- 1) After having connected item n° 4 062 89 to 230V ~ network, put the handle on ON position, switch the selector from "AUTO" position to "MAN" position then again to "AUTO" position.
- 2) The first automatic test of the residual current detection is carried out instantaneously. The next test will be carried out 56 days and 8 hours after the first test and this test will be shifted during the night. Then the next tests will occur every 56 days (8 weeks).

• Einstellung:

- 1) Nach erfolgtem Anschluss der Artikelnummer 4 062 89 an das 230V~ Netz bitte den Handschalter auf ON stellen und den Umschalter von Position "AUTO" auf Position "MAN" und dann wieder auf Position "AUTO" betätigen.
- 2) Der erste automatische Test der Fehlerstromerkennung wird sofort ausgeführt. Der nächste Test wird nach 56 Tagen (8 Wochen) und 8 Stunden nach dem ersten Test ausgeführt, dieser Test schaltet während der Nacht. Die folgenden Tests werden dann alle 56 Tage (8 Wochen) ausgeführt.

• Programación:

- 1) Una vez alimentada la referencia 4 062 89, colocar la maneta en posición ON, pasar el selector de la posición "AUTO" a la posición "MAN" y volver a pasarlo a la posición "AUTO".
- 2) El primer test automático de la función diferencial es instantáneo. El siguiente test se realizará 56 días y 8 horas después de realizarse el primero y permitirá decalar este test a las horas nocturnas. Los tests sucesivos se realizarán cada 56 días (8 semanas).

• Programação:

- 1) Após colocar sob tensão a ref. 4 062 89, colocar a manete na posição "ON", passar o seletor da posição "AUTO" para a posição "MAN" e passá-lo de novo para a posição "AUTO".
- 2) O primeiro teste automático da função diferencial é efetuado imediatamente. O teste seguinte será efetuado 56 dias e 8 horas depois do primeiro, para que fique em horário noturno. Os testes seguintes serão efetuados a cada 56 dias (8 semanas).

• Программирование:

- 1) После подключения к источнику питания кат. № 4 062 89 установите рычаг в положение ON (ВКЛ), переведите переключатель из положения "AUTO" (АВТО) в положение "MAN" (РУЧН.), а затем верните в положение "AUTO" (АВТО).
- 2) Первая проверка функции защиты от тока утечки будет выполнена сразу же после завершения операций из п 1. Следующая проверка будет выполнена через 56 дней и 8 часов для его сдвига на ночное время. Все последующие проверки выполняются раз в 56 дней (8 недель).

• Programowanie:

- 1) Po podłączeniu aparatu o nr referencyjnym 4 062 89 do sieci 230V~, należy przestawić dźwignię załączającą aparatu w pozycję ON, programowanie następuje poprzez przestawienie przełącznika rodzaju pracy z pozycji "AUTO" na "MAN" i następnie z powrotem na pozycję "AUTO".
- 2) Pierwszy automatyczny test prądem różnicowym będzie wykonany natychmiastowo. Następny test będzie wykonany po 56 dniach i 8 godzinach po pierwszym teście i powinien być przeprowadzony w godzinach nocnych. Następne testy będą wykonywane co 56 dni (8 tygodni).

• Programlama:

- 1) 4 062 89 referanslı ürüne enerji verdikten sonra, mandali ON konumuna getirin, islev seçiciyi "AUTO" konumundan "MAN" konumuna getirin ve sonra tekrar "AUTO" konumuna getiriniz.
- 2) Kaçak akım islevinin ilk otomatik testi anında gerçekleşecektir. Bir sonraki test ilk testten 56 gün 8saat sonra gerçekleşecek olup böylelikle testlerin gece gerçekleşmesi sağlanmış olacaktır. Sonraki testler her 56 günde (8 hafta) bir gerçekleşecektir.

• البرمجة

بعد توصيل 406289 يجب تغيير AUTO لموقف MAN و التغيير مرة أخرى إلى AUTO الاختبار الاوتوماتيكي الدوري يتحقق كل 56 يوما (8 أسابيع) و 8 ساعات بعد تنفيذ البرنامج المذكور أعلاه أولا ، ثم كل 56 يوما

4062 88/89

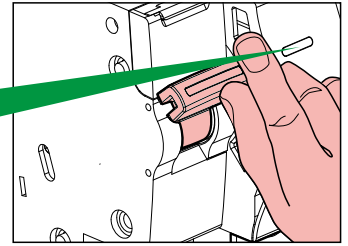
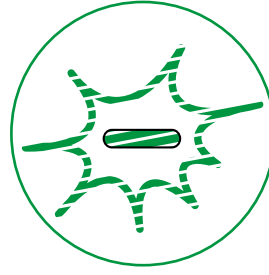
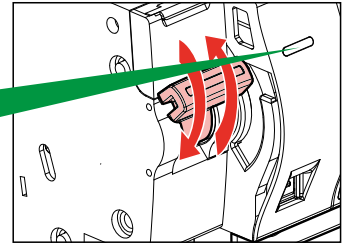
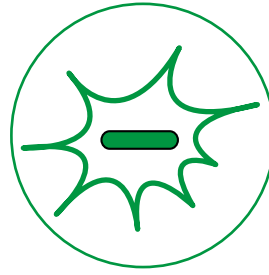
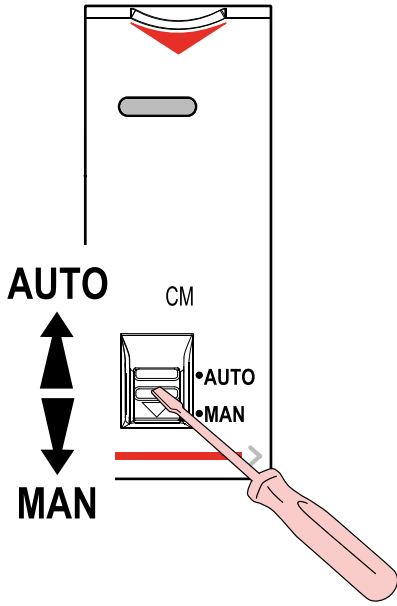

4062 88/89

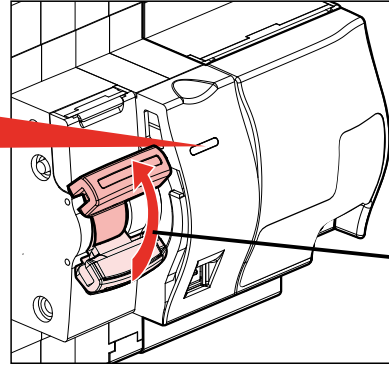

4062 88/89

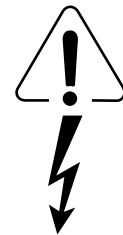
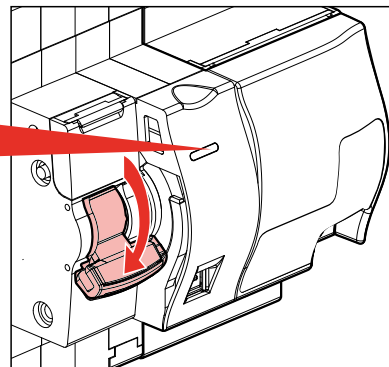
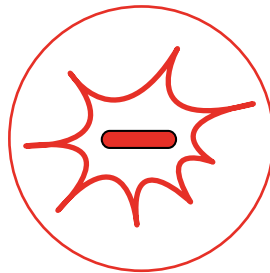

4062 88/89
Auto test

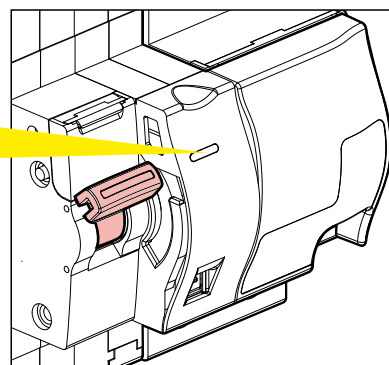
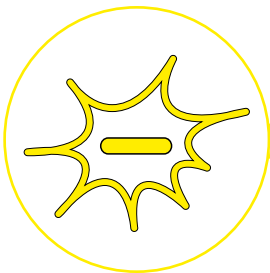

$I_{\Delta} > 30 \text{ mA}$

- Rd0 (résistance nominale de non fonctionnement entre les parties actives et la terre) 225 kΩ
- Rd (résistance nominale de fonctionnement entre les parties actives et la terre) 375 kΩ
- Rcc0 (résistance nominale de non fonctionnement entre parties actives) 0,75 Ω
- Rcc (résistance nominale de fonctionnement entre parties actives) 1,25 Ω

Le dispositif peut être utilisé dans les systèmes de schéma de liaison à la terre TT et TN

- Rd0 (ingestelde niet-operationele weerstand tussen actieve delen en aarde) 225 kΩ
- Rd (ngestelde operationele weerstand tussen actieve delen en aarde) 375 kΩ
- Rcc0 (ingestelde niet-operationele weerstand tussen actieve delen) 0,75 Ω
- Rcc (ngestelde operationele weerstand tussen actieve delen) 1,25 Ω

De apparaten kunnen worden gebruikt in TT en TN nulleidertstelsel

- Rd0 (rated non operating resistance between live parts and earth) 225 kΩ
- Rd (rated operating resistance between live parts and earth) 375 kΩ
- Rcc0 (rated non operating resistance between live parts) 0,75 Ω
- Rcc (rated operating resistance between live parts) 1,25 Ω

The devices may be used in TT and TN earthing system

- Rd0 (Nennbetriebswiderstand im unbetätigten Zustand zwischen aktiven Teilen und Erde) 225 kΩ
- Rd (Nennbetriebswiderstand im betätigten Zustand zwischen aktiven Teilen und Erde) 375 kΩ
- Rcc0 (Nennbetriebswiderstand im unbetätigten Zustand zwischen aktiven Teilen) 0,75 Ω
- Rcc (Nennbetriebswiderstand im betätigten Zustand zwischen aktiven Teilen) 1,25 Ω

Die Geräte sind für die Netzform TT und TN geeignet.

- Rd0 (resistencia nominal de no funcionamiento entre las partes activas y tierra) 225 kΩ
- Rd (resistencia nominal de funcionamiento entre las partes activas y tierra) 375 kΩ
- Rcc0 (resistencia nominal de no funcionamiento entre partes activas) 0,75 Ω
- Rcc (resistencia nominal de funcionamiento entre partes activas) 1,25 Ω

El dispositivo puede utilizarse en los sistemas TT y TN de distribución de neutro.

- Rd0 (resistência à terra de não funcionamento) 225 kΩ
- Rd (resistência à terra de funcionamento) 375 kΩ
- Rcc0 (resistência entre fases de não funcionamento) 0,75 Ω
- Rcc (resistência entre fases de funcionamento) 1,25 Ω

Estes dispositivos podem ser utilizados em regimes de neutro TT e TN

- Номинальное аварийное сопротивление между частями электроустановки, находящимися под напряжением и землей 225 kΩ
- Номинальное рабочее сопротивление между частями электроустановки, находящимися под напряжением и землей 375 kΩ
- Номинальное аварийное сопротивление между частями электроустановки, находящимися под напряжением 0,75 Ω
- Номинальное рабочее сопротивление между частями электроустановки, находящимися под напряжением 1,25 Ω

Данное оборудование может применяться в системах с режимами нейтрали TT и TN

Polish:

- Rd0 - (rezystancja nie pozwalająca na załączenie, wartość rezystancji pomiędzy przewodami czynnymi i uziemieniem) 225kΩ
- Rd - (rezystancja pozwalająca na załączenie, wartość rezystancji pomiędzy przewodami czynnymi i uziemieniem) 375kΩ
- Rcc0 - (rezystancja nie pozwalająca na załączenie, wartość rezystancji pomiędzy przewodami czynnymi) 0,75Ω
- Rcc - (rezystancja pozwalająca na załączenie, wartość rezystancji pomiędzy przewodami czynnymi) 1,25Ω

Te aparaty mogą być stosowane w układach sieci TT i TN

- Rd0 (faz ile toprak arasindaki bosta anma direnci) 225 kΩ
- Rd (faz ile toprak arasindaki çalisma anma direnci) 375 kΩ
- Rcc0 (gerilim altindaki kisimlar arasindaki bosta anma direnci) 0,75 Ω
- Rcc (gerilim altindaki kisimlar arasindaki çalisma anma direnci) 1,25 Ω

Bu cihaz TT ve TN nötr rejimlerinde kullanılabilir.

- ۲۲۵ k Ω المقاومة المقننة الغير تشغيلية بين الأجزاء الحية و الأرضي. (Rd0)
 - ۳۷۵ k Ω المقاومة المقننة التشغيلية بين الأجزاء الحية و الأرضي. (Rd)
 - ۰,۷۵ Ω المقاومة المقننة الغير تشغيلية بين الأجزاء الحية. (Rcc0)
 - ۱,۲۵ Ω المقاومة المقننة التشغيلية بين الأجزاء الحية. (Rcc)
- يمكن استخدام هذه الأجهزة مع أنظمة التأسيس TT و NT

				4 062.. 88 / 89
				4 062.. 58 / 60 / 62 / 66
				4 062.. 58 / 60 / 62
				4 062.. 88 / 89
				4 062.. 58 / 60 / 62 / 66

<p>Ne pas respecter strictement les conditions d'installation et d'utilisation peut entraîner des risques de choc électrique ou d'incendie.</p> <p>Door de installatie- en gebruiksvoorwaarden niet strikt na te leven, kan er gevaar voor elektrische schokken of brand ontstaan.</p> <p>The instructions for installation and use must be strictly observed in order to avoid the risk of electric shock or fire.</p> <p>Bei Nichtbeachtung der Einbau- und Nutzungsvorschriften besteht Stromschlag- bzw. Brandgefahr.</p> <p>El no cumplimiento estricto de las instrucciones de instalación y uso puede implicar riesgos de choque eléctrico o incendio.</p> <p>Il non rispetto alla lettera delle condizioni d'installazione e di utilizzo può generare rischi di scariche elettriche o di incendio.</p> <p>Não respeitar estritamente as condições de instalação e de utilização poderá provocar riscos de choque eléctrico ou de incêndio.</p> <p>Η μη αυστηρή τήρηση των συνθηκών εγκατάστασης και χρήσης μπορεί να επιφέρει κινδύνους ηλεκτροπληξίας ή πυρκαγιάς.</p> <p>Несоблюдение правил монтажа и эксплуатации может повлечь за собой риск поражения электрическим током или возникновения пожара.</p> <p>Niezastosowanie się ściśle do warunków instalacji i użytkowania może grozić porażeniem prądem lub pożarem.</p> <p>Yerleşirme ve kullanim koşullarına uyulmaması elektrik çarpması veya yangın risklerine yol açabilir.</p> <p>A beszerelési és használati feltételek szigorú betartásának elmulasztása áramütés vagy tűz kockázatával jár.</p> <p>Jos et noudata tarkasti asennus- ja käyttöohjeita, voit aiheuttaa sähköiskun vaaran tai tulipalon.</p>	<p>FR LU BE CH</p> <p>NL BE</p> <p>GB IE</p> <p>DE AT LI CH</p> <p>ES</p> <p>IT CH</p> <p>PT</p> <p>GR CY</p> <p>RU</p> <p>PL</p> <p>TR CY</p> <p>HU</p> <p>FI</p>	<p>Om installationsvilkoren inte uppfylls strikt, föreligger risk för elchocker eller brand. Nedodržení stanovených podmínek instalace a používání může vést k rizikům zasažení elektrickým proudem nebo požáru. V prípade nedodržania presných podmienok týkajúcich sa inštalácie a používania hrozí riziko úrazu elektrickým prúdom alebo vzniku požiaru. Neupoštevanje vseh pogojev instalacije in uporabe lahko povzroči nevarnost električnega udara ali požara. Hvis installations- og brugsbetingelserne ikke strengt overholdes, kan det medføre risiko for elektrisk stød eller brand. Kui paigaldamis- ja kasutustingimusi ei järgita rangelt, võib see kaasa tuua elektrišoki või tulekahjuohtu. Precizi neievērojot uzstādīšanas un lietošanas noteikumus, pieaug elektriskās strāvas trieciena vai ugunsgrēka iespējamība. Tiksliai nesilaikant instaliavimo ir naudojimo sąlygų gali kilti trumpojo elektros jungimo arba gaisro pavojus. Manglende overhold av installasjons- og brugsbetingelsene kan føre til elektrisk støt eller brann. Ef skilyrdum um uppsetningu og notkun er ekki vandlega fylgt kann slíkt að valda hættu á raflosti eða eldsvoða. Nerespectarea strictă a condițiilor de instalare și utilizare poate genera riscuri de șocuri electrice sau incendiu. Неспазването стриктно на указанията за сглобяване и използване може да доведе до риск от токов удар или пожар.</p>	<p>SE</p> <p>CZ</p> <p>SK</p> <p>SI</p> <p>DK</p> <p>EE</p> <p>LV</p> <p>LT</p> <p>NO</p> <p>IS</p> <p>RO</p> <p>BG</p>
---	--	--	---