

STOP&GO connected kit and automatic resetting



4 149 54



4 062 88

Pack	Cat.Nos	Connected STOP&GO (remote control resetting)				
1	4 149 54	<p>For remotely switching (via a smartphone or tablet) 1 module per pole RCCBs and RCBOs up to 63 A. Examples of use:</p> <ul style="list-style-type: none"> - In the event of unwanted tripping (generated by temporarily electrical disturbances or other external events) the Connected STOP&GO will do an automatic checking of the installation. If no permanent fault is detected: it will send a message on the smartphone or tablet of the user in order to get an authorization to switch on the associated device. - In case of permanent fault: the user will be informed about it without having the possibility to remotely switch on the power. - Needs a permanent internet connection via a Wi-Fi modem/router (powered by an UPS) in order to send messages to the user and allow him to remotely control the circuit. - In a normal situation, to remotely switch ON a circuit (like the electrical heating in a holiday house). Can take one control auxiliary and one signalling auxiliary. The signalling auxiliary must be placed between the STOP&GO and the control auxiliary. No tool required for assembling. <p>Kit comprising:</p> <ul style="list-style-type: none"> - 1 Connected STOP&GO (non-automatic) - 1 IP gateway (Wi-Fi connection) - 1 power supply module, input voltage 230 V~/ output voltage 12 V= - 2 communication cables <table border="1"> <thead> <tr> <th>Control voltage</th> <th>No. of modules</th> </tr> </thead> <tbody> <tr> <td>230 V~</td> <td>4</td> </tr> </tbody> </table>	Control voltage	No. of modules	230 V~	4
Control voltage	No. of modules					
230 V~	4					

Pack	Cat.Nos	STOP&GO automatic resetting				
1	4 062 88	<p>For automatic resetting of 1 module per pole RCCBs and RCBOs up to 63 A. STOP&GO is used in the event of unwanted tripping generated by temporarily electrical disturbances or other external events. Can take one control auxiliary and one signalling auxiliary. The signalling auxiliary must be placed between the STOP&GO and the control auxiliary. No tool required for assembling.</p> <p>Automatic resetting function</p> <table border="1"> <thead> <tr> <th>Control voltage</th> <th>No. of modules</th> </tr> </thead> <tbody> <tr> <td>230 V~</td> <td>2</td> </tr> </tbody> </table>	Control voltage	No. of modules	230 V~	2
Control voltage	No. of modules					
230 V~	2					
1	4 062 89	<p>Automatic resetting + periodic self-test function</p> <table border="1"> <thead> <tr> <th>Control voltage</th> <th>No. of modules</th> </tr> </thead> <tbody> <tr> <td>230 V~</td> <td>2</td> </tr> </tbody> </table>	Control voltage	No. of modules	230 V~	2
Control voltage	No. of modules					
230 V~	2					

Manual supply inverter DX³ and accessories



4 063 14

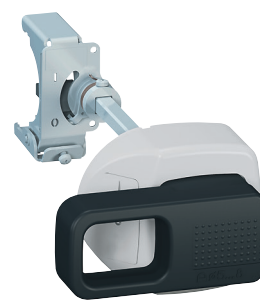

4 063 19

Pack	Cat.Nos	Manual supply inverter (MSI)
		<p>For manually switching between the mains and an alternative power supply. Allow to restore power on pre-designated and/or critical circuits in case of a power failure of the main supply. For DX³ MCBs and remote trip isolating switches. Installation principle - see e-catalogue</p> <ul style="list-style-type: none"> For 2P 2-module devices For 3P 3-module devices For 4P 4-module devices
1	4 063 14	
1	4 063 15	
1	4 063 16	
		<p>Front external rotary handles</p> <p>Allow the manual control (open/close) of a modular device without opening the enclosure. For all DX³, TX³ and RX³ devices from 2P upwards. Supplied with bracket, connection rod, handle, self-adhesive drilling template and connection accessories. Installation principle - see e-catalogue</p> <ul style="list-style-type: none"> Black handle Yellow and red handle
1	4 063 19	
1	4 063 20	
		<p>Wiring management accessories</p> <p>Insulating shields</p> <p>For 1 module per pole MCBs. For separation between the terminals of the MCB, when using high cross section cables.</p>
1	4 063 05	
10	4 063 07	
		<p>Spacing unit with feedthrough</p> <p>0.5 module. Allows cables to run between two modular devices and creates an air channel in order to limit temperature rise.</p>
1	4 063 10	
1	4 063 11	
		<p>Terminals for aluminium cables</p> <ul style="list-style-type: none"> For 1 and 1.5 module/pole MCBs up to 63 A For 1.5 module/pole MCBs and remote trip isolating switches from 80 A to 125 A
		<p>Safety and maintenance accessories</p> <p>Sealable screw covers</p> <ul style="list-style-type: none"> For 1 module per pole MCBs (set of 4) For 1.5 module per pole MCBs (set of 4)
2	4 063 04	
1	4 063 12	
		<p>Terminal shield</p> <p>For 1.5 module/pole MCBs (set of 2)</p>
1	4 063 06	
		<p>Padlocking</p> <p>To lock the handle of a modular device during maintenance.</p> <ul style="list-style-type: none"> Large padlock, Ø6 mm, 50 mm length. Supplied with two keys and labels Small padlock, Ø5 mm Support for one padlock (for small or large model) For locking the handle of the modular devices (MCBs, RCCBs, RCBOs or isolating switches) in OFF position
1	0 227 97	
3	4 063 13	
2	4 063 03	

Voltage surge protectors
p. 66-70

Keor UPS
p. 678

Dimensions of din-rail equipment

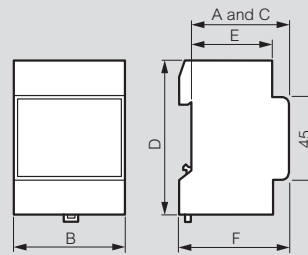
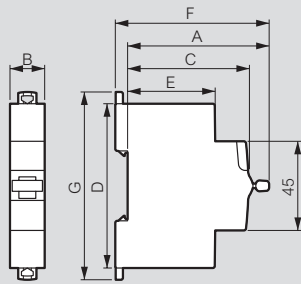

Product	A		B				C	D	E	F	G
	1P	1P+ N	2P	3P	4P						
RX³ MCBs	71.7	17.7	35.4	35.4	53.1	70.8	61	83	44	77.8	88.9
RX³ RCCBs	71.7			35.6		71.2	61	83	44	77.8	88.9
TX³ MCBs	71.7	17.7	35.4	35.4	53.1	70.8	61	83	44	77.8	88.9
TX³ RCCBs	71.7			35.6		71.2	61	83	44	77.8	88.9
Isolating switches DX³	71.7	17.8		17.8/ 35.4	35.6/ 53.1	70.8	61	83	44	77.8	94.8
Remote trip head isolating switches DX³ up to 63A - 1 mod/pole	71.7			35.4	53.1	70.8	61	83	44	77.9	94.8
Remote trip head isolating switches DX³ 100/125A - 1.5 mod/pole	73				80.1	106.8	61	96	47	79	104.3
DX³ RCCBs	71.7			35.6		71.2	61	83	44	77.8	94.8
1P DX³ RCBOs (up to 45A)	68	17.7					60	115	48	74	126.8
1P+N DX³ RCBOs (up to 40A) & 4P (up to 32A)	71.7		35.6			71.2	61	83	44	77.8	94.8
2P & 4P DX³ RCBOs (40A to 63A)	72			71.2		124.6	61	96	44	78.2	107.8
1P+N DX³ MCBs 1 mod	71.7		17.8				61	83	44	77.8	94.8
DX³ MCBs - 1 mod/pole	71.7	17.7	35.4	35.4	53.1	70.8	61	83	44	77.8	94.8
DX³ MCBs - 1,5 mod/pole	73.1	26.7		53.4	80.1	106.8	61	100	47	79	104.3
DX³ add-on modules up to 63A - 1 mod/pole	72			35.6	53.4	53.4	61	96	44	78.2	107.8
DX³ add-on modules up to 63A - 1.5 mod/pole	72			35.6	53.4	53.4	61	96	47	78.2	116.7
DX³ add-on modules 80 to 125A - 1.5 mod/pole	72			71.2	106.8	106.8	61	114	47	78.2	129
DX³ auxiliaries	71.5			8.8 / 17.7			61	83	44	77.7	84.5
DX³ remote control	74.3			17.7 / 35.4			61	83	44	80.5	98.8
DX³ Stop&Go automatic resetting	74.3			35.4			61	83	44	80.5	113.7
Change-over switches	68	17.7		35.6			60	83	44	74	94
CX³ latching relays	64	17.8		17.8	35.6	35.6	61	84.5	44	70.2	94.8
CX³ contactors up to 25A	66.3/ 61	17.8		17.8	35.6	35.6	61	84.5	44	72.6/ 67.3	94.8
CX³ contactors 40A & 63A	62			35.6	53.4	53.4	60	83	44	68	94
Auxiliaries for CX³ contactors and latching relays	61			9/17.8			61	84.5	44	67	84.5
Push-buttons / control switches	68			17.7			60	83	44	74	94
Indicators	68			17.7			60	83	44	69	94
Bells and buzzers	60			17.7			60	76	44	66	85
Light sensitive switches											
Cat.Nos 0 037 21, 4 126 23	60			35.6			60	85	37.5	66	70
Socket outlets	60			44.5			60	83	44	66	92
Time delay relays	60			17.7			60	83	44	66	94
Remote control dimmers											
Cat.No 0 036 58	60			36			60	83	44	66	94
Cat.No 0 036 60	60			72			60	83	44	66	94
Cat.No 0 036 71	60			108			60	83	44	66	94

Description	A	B	C	D	E	F
Programmable time switches						
0 037 05	60	17.8	60	83	44	66
4 127 80/90/94	60	17.8	60	83	44	66
4 127 95, 4 128 12/13	60	53	60	83	44	66
4 126 31/33/41	60	35.6	60	83	44	66
4 126 54/57	60	35.6	60	83	44	66
0 047 70	60	90	60	83	44	66
Transformers and power supplies						
0 042 10/30/31	60	72	60	83	44	66
4 130 91	60	35.8	60	83.5	44	66
4 130 92/93/96	60	71.5	60	83.5	44	66
4 130 98	60	89	60	94	44	66
0 047 91/92	60	105	60	95	44	66
4 131 05/06/07/08	60	89	60	95	44	66
0 047 93	60	70	60	95	44	66
Residual current relay						
0 260 88	60	35.5	60	89	44	66

DX³ Manual Supply Invertor

Cat. Nos: 4 063 14/15/16



CONTENTS	PAGE
1. Description - Use	1
2. Range	1
3. Overall dimensions	1
4. Preparation - Connection	1
5. General Characteristics.....	3
6. Compliance and approvals.....	3

1. DESCRIPTION - USE:

For a pre-defined circuit the Manual Supply Invertor (MSI), allows the end user to manually switch to another power source (ex. a generator) when the mains supply is not available

2. RANGE

Cat. Nos:

- . 4 063 14 : for devices 2 poles/2 modules.
- . 4 063 15 : for devices 3 poles/3 modules.
- . 4 063 16 : for devices 4 poles/4 modules.

3. OVERALL DIMENSIONS:

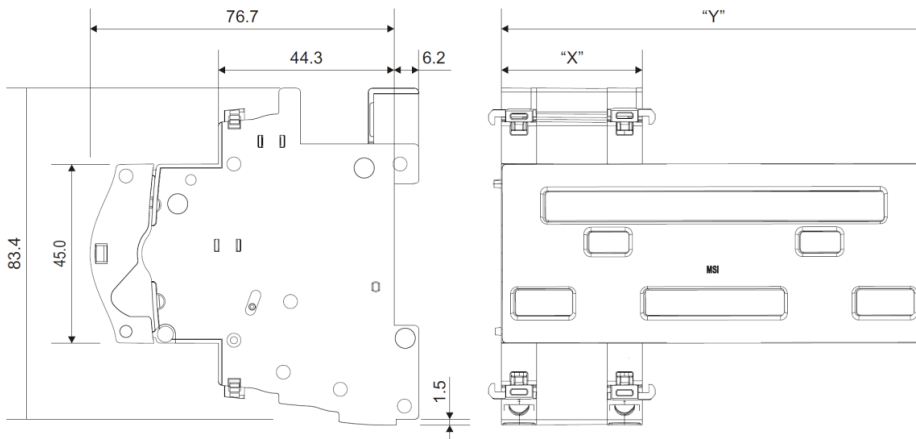

Cat. Nos	"X" (mm)	"Y" (mm)
4 063 14	17.8 mm	53.1 mm
4 063 15	35.6 mm	89.0 mm
4 063 16		106.8 mm

4. PREPARATION –CONNECTION

Fixing:

- . On symmetric rail EN/IEC 60715 or DIN 35 rail, by the device which is associated.

Operating positions:

- . Vertical, horizontal, upside down, on the side



4. PREPARATION –CONNECTION (continued)

Supply:

. No power supply.

Assembling:

- . Between two modular protection devices (see the association table for the type of products to associate)
- . Clipped on the associated device by mean of plastic clamps present on each side of MSI.

. Assembling on the right side

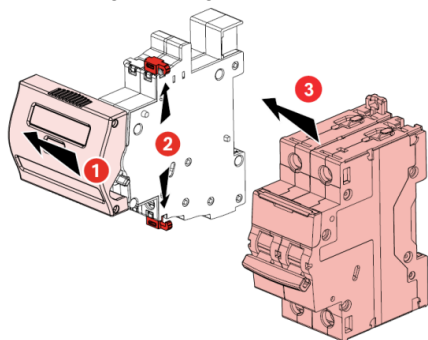

. Assembling on the left side

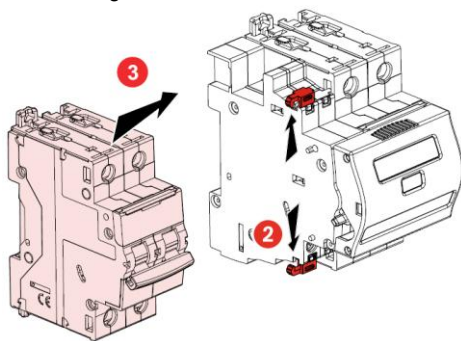

Tools required:

- . Fixing the MSI and protection devices: no tools.
- . Fixing on the DIN rail: no tools.
- . To remove the security seals: flat screwdriver 5,5 mm (6 mm maximum).

Lockout:

. The MSI is equipped with security seals that ensure the association between MSI and the associated device.

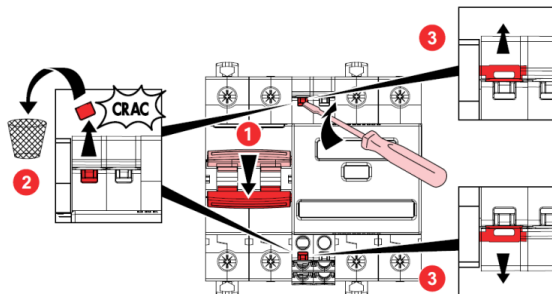

. It is possible to lock the protection device (MCB or IS) associated to the MSI by padlock (cat. nos 4 063 13 or 227 97) and padlock support (cat. no 4 063 03).

4. PREPARATION –CONNECTION (continued)

Operation:

- . To perform the source inversion:
- 1. Lower the handle of the protection device powered-on.

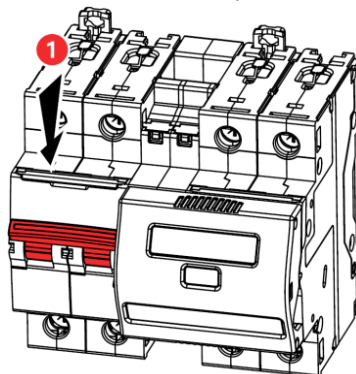

- 2. Slide the frontal slider on the device with the handle lowered.

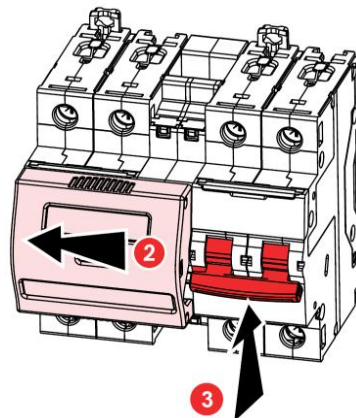

- 3. Lift the handle of the other circuit breaker to restore the supply.

Association table

	$\begin{matrix} 1 & 3 & 5 \\ 2 & 4 & 6 \\ 1 & 3 \\ 2 & 4 \end{matrix}$	4 063 14	$\begin{matrix} 1 & 3 & 5 \\ 2 & 4 & 6 \\ 1 & 3 \\ 2 & 4 \end{matrix}$
	$\begin{matrix} 1 & 3 & 5 \\ 2 & 4 & 6 \\ 1 & 3 & 5 \\ 2 & 4 & 6 \\ 2 & 4 & 6 \end{matrix}$	4 063 15	$\begin{matrix} 1 & 3 & 5 \\ 2 & 4 & 6 \\ 1 & 3 & 5 \\ 2 & 4 & 6 \\ 2 & 4 & 6 \end{matrix}$
	$\begin{matrix} 1 & 3 & 5 & 7 \\ 2 & 4 & 6 & 8 \\ 1 & 3 & 5 & 7 \\ 2 & 4 & 6 & 8 \\ 2 & 4 & 6 & 8 \end{matrix}$	4 063 16	$\begin{matrix} 1 & 3 & 5 & 7 \\ 2 & 4 & 6 & 8 \\ 1 & 3 & 5 & 7 \\ 2 & 4 & 6 & 8 \\ 2 & 4 & 6 & 8 \end{matrix}$

5. GENERAL CHARACTERISTICS

Front face marking:

- . By permanent ink pad printing:
 - Device name: MSI
 - Directional arrows
 - Legrand reference code and Logo 
 - Mark: Legrand.

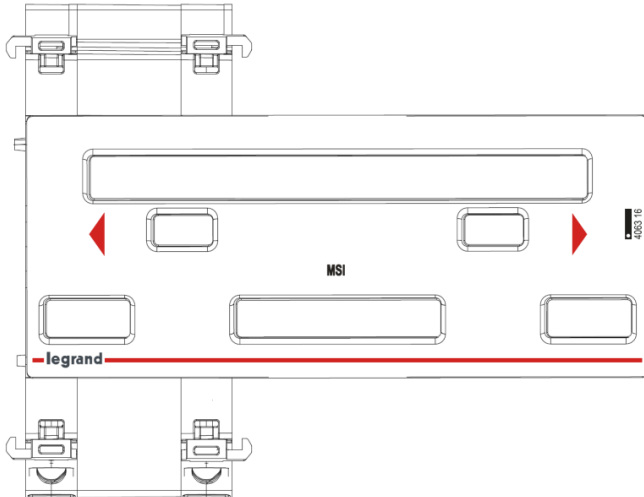

Plastic materials:

- . 10% Glass fiber reinforced polycarbonate
- . Characteristics of this material: self extinguishing, heat and fire resistant according to EN 60898-1, glow-wire test at 960°C.

Average weight per device:

Cat.Nos	Weight (kg)
4 063 14	0,057
4 063 15	0,089
4 063 16	0,094

Volume when packed:

Cat.Nos	Volume (m ³)
4 063 14	0,49
4 063 15	1.25
4 063 16	

Ambient temperature:

- . operating= - 25 °C Max. = + 60 °C.
- . storage= - 25 °C Max. = + 60 °C.

5. GENERAL CHARACTERISTICS (continued)

Class protection:

- . Protection index of the box against solid and liquid bodies: IP40 (in accordance with standards IEC 529, EN 60529 and NF C 20-010).

Sinusoidal vibration resistance in accordance with IEC 60068-2-6:

- . Axes : x, y, z.
- . Frequency: 5÷100 Hz ; duration 90 minutes
- . Displacement (5÷13,2 Hz) : 1mm
- . Acceleration (13,2÷100 Hz) : 0,7g (g=9,81 m/s²)

Power dissipated (W) :

- . 0 W.

Identification:

- . MSI is equipped with several windows, so all information of the associated device remain visible

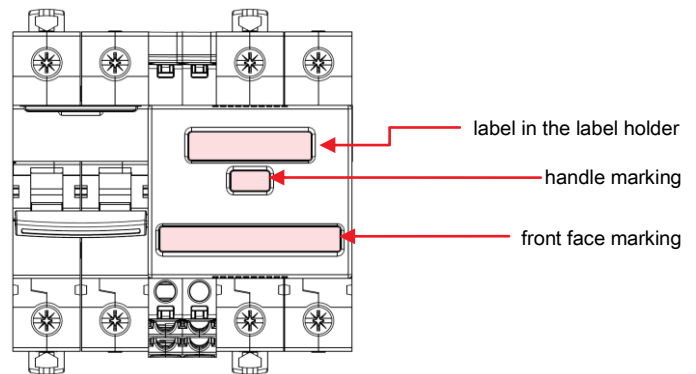

6. COMPLIANCE AND APPROVALS

In accordance with:

- . CEE guidelines : 73/23/CEE + 93/68/CEE
- . Legrand devices can be used under the conditions of use as defined by IEC /EN 60947-1
- . The performance of circuit breakers can be influenced by particular climates: hot dry, cold dry, hot humid, salt fog atmosphere

Plastic materials :

- . Halogens-free plastic materials.
- . Marking of parts according to ISO 11469 and ISO 1043.

Packaging:

- . Design and manufacture of packaging in accordance with decree 98-638 of 07.20.98 and Directive 94/62/EC

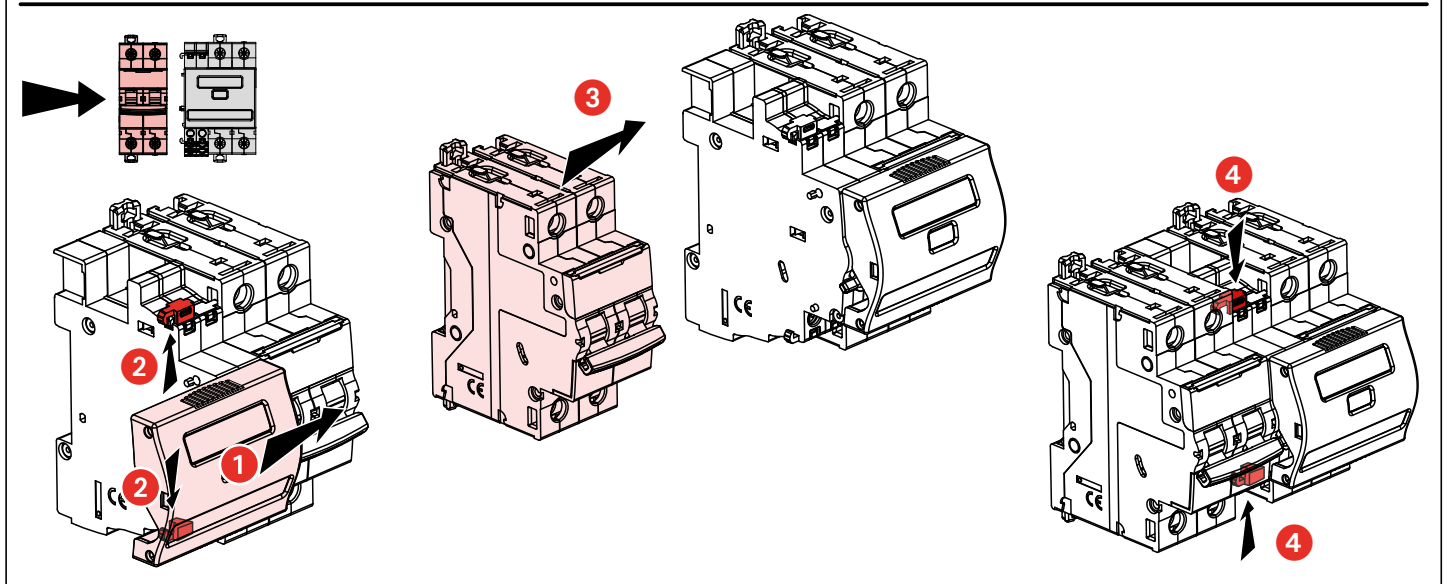
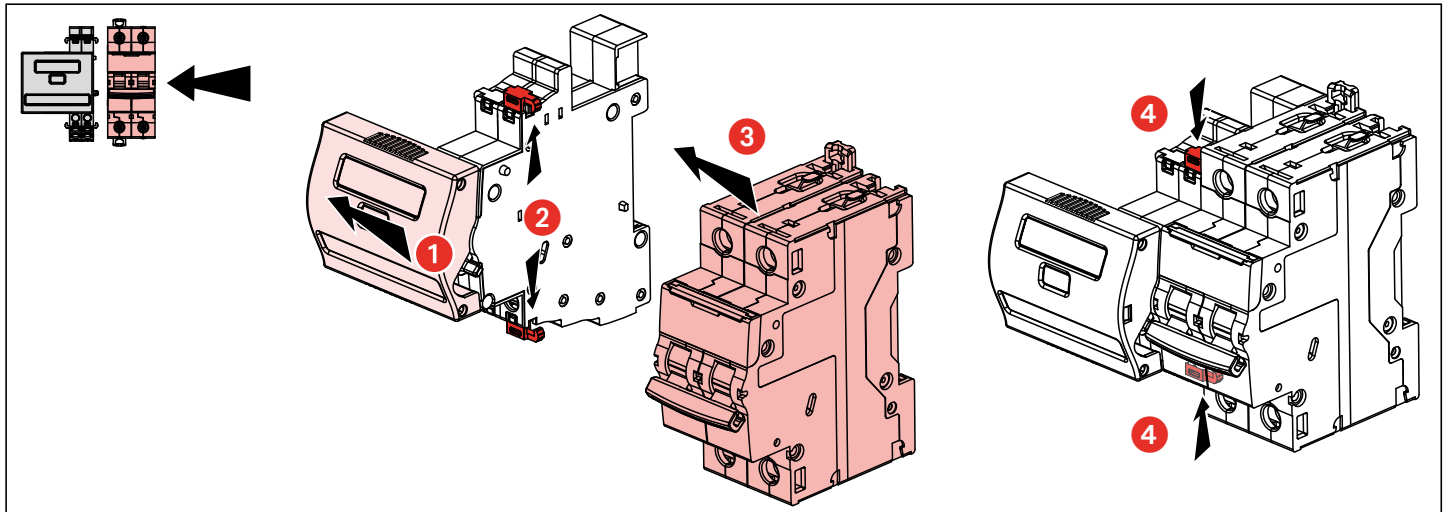
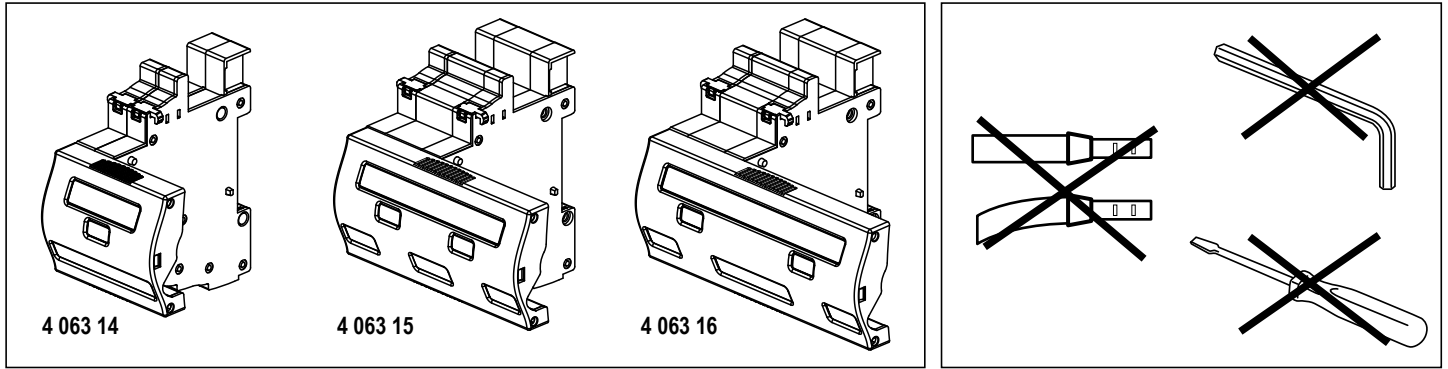

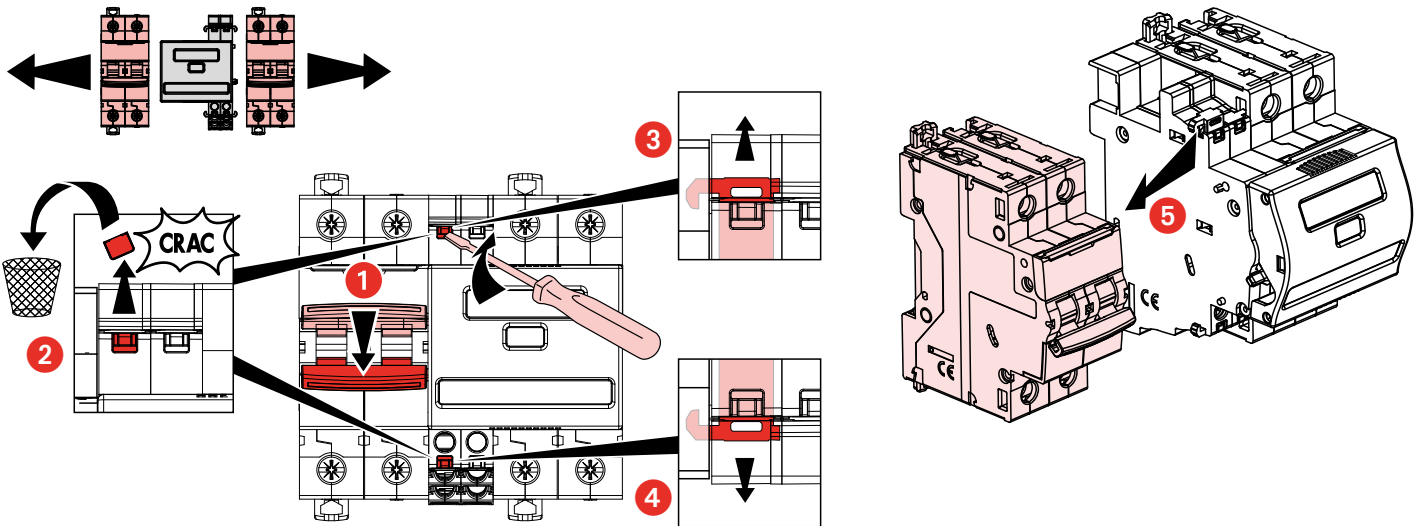
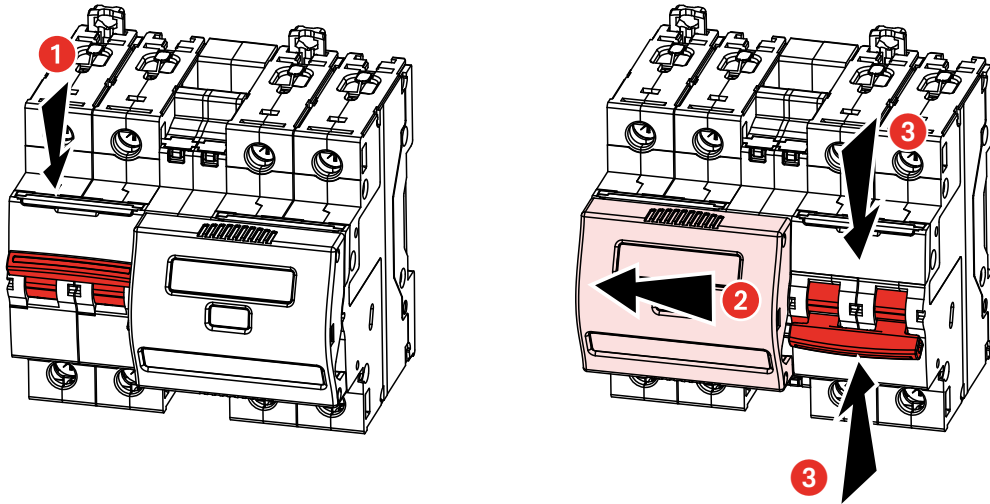
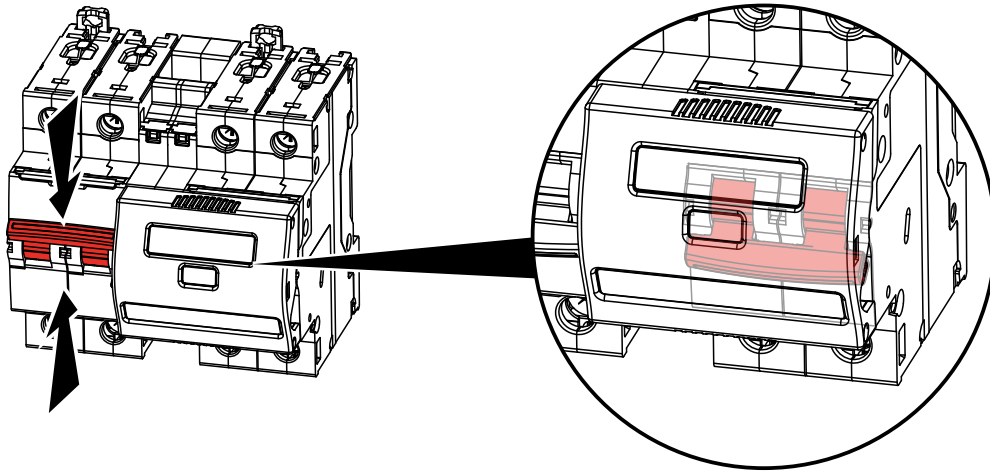

Ne pas respecter strictement les conditions d'installation et d'utilisation peut entraîner des risques de choc électrique ou d'incendie.

Door de installatie- en gebruiksvoorwaarden niet strikt na te leven, kan er gevaar voor elektrische schokken of brand ontstaan.

The instructions for installation and use must be strictly observed in order to avoid the risk of electric shock or fire.

Bei Nichtbeachtung der Einbau- und Nutzungsvorschriften besteht Stromschlag- bzw. Brandgefahr.

El no cumplimiento estricto de las instrucciones de instalación y uso puede implicar riesgos de choque eléctrico o incendio.

Il non rispetto alla lettera delle condizioni d'installazione e di utilizzo può generare rischi di scariche elettriche o di incendio.

Não respeitar estritamente as condições de instalação e de utilização poderá provocar riscos de choque eléctrico ou de incêndio.

Η μη αυστηρή τήρηση των συνθηκών εγκατάστασης και χρήσης μπορεί να επιφέρει κινδύνους ηλεκτροπληξίας ή πυρκαγιάς.

Несоблюдение правил монтажа и эксплуатации может повлечь за собой риск поражения электрическим током или возникновения пожара.

Niezastosowanie się ściśle do warunków instalacji i użytkowania może grozić porażeniem prądem lub pożarem.

Yerleşirme ve kullanım koşullarına uyulmaması elektrik çarpması veya yangın risklerine yol açabilir.

A beszerelési és használati feltételek szigorú betartásának elmulasztása áramütés vagy tűz kockázatával jár.

Jos et noudata tarkasti asennus- ja käyttöohjeita, voit aiheuttaa sähköiskun vaaran tai tulipalon.

FR LU BE CH

NL BE

GB IE

DE AT LI CH

ES

IT CH

PT

GR CY

RU

PL

TR CY

HU

FI

Om installationsvilkoren inte uppfylls strikt, föreligger risk för elchocker eller brand.

Nedodržení stanovených podmínek instalace a používání může vést k rizikům zasažení elektrickým proudem nebo požáru.

V prípade nedodržania presných podmienok týkajúcich sa inštalácie a používania hrozí riziko úrazu elektrickým prúdom alebo vzniku požiaru.

Neupoštevanje vseh pogojev instalacije in uporabe lahko povzroči nevarnost električnega udara ali požara.

Hvis installations- og brugsbetingelserne ikke strengt overholdes, kan det medføre risiko for elektrisk stød eller brand.

Kui paigaldamis- ja kasutustingimusi ei järgita rangelt, võib see kaasa tuua elektrišoki või tulekahjuohtu.

Precizni neievērojot uzstādīšanas un lietošanas noteikumus, pieaug elektriskās strāvas trieciena vai ugunsgrēka iespējamība.

Tiksliai nesilaikant instaliavimo ir naudojimo sąlygų gali kilti trumpojo elektros jungimo arba gaisro pavojus.

Manglende overhold av installasjons- og bruksbetingelsene kan føre til elektrisk støt eller brann.

Ef skilyrðum um uppsetningu og notkun er ekki vandlega fylgt kann slíkt að valda hættu á raflosti eða eldsvoða.

Nerespectarea strictă a condițiilor de instalare și utilizare poate genera riscuri de șocuri electrice sau incendiu.

Неспазването стриктно на указанията за спсобяване и използване може да доведе до риск от токов удар или пожар.

SE

CZ

SK

SI

DK

EE

LV

LT

NO

IS

RO

BG