

Add-on modules DX³

for 1.5 module/pole DX³ MCBs

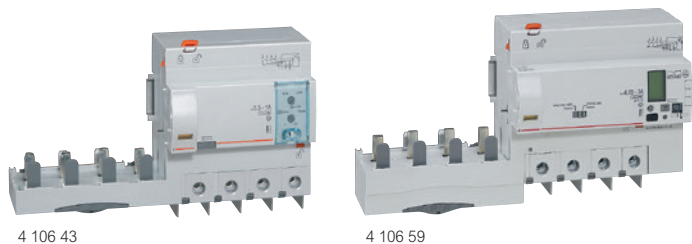

Technical characteristics **see e-catalogue**

Conform to IEC 61009-1

- AC type : detect AC components faults
- Hpi type : detect faults with AC and DC components, increased immunity to false tripping

For mounting on the right-hand side of 1.5 module per pole DX³ MCBs

Pack	Cat.Nos	2-pole - 230 V \sim			
1	4 105 76	Hpi Type	Sensitivity (mA)	Nominal rating In (A)	Number of modules
	4 105 77		30	63	2
1	4 105 83	Hpi Type adjustable	from 300 to 1000	63	4
	4 105 84		from 300 to 1000	125	4
1	4 106 05	Hpi Type	Sensitivity (mA)	Nominal rating In (A)	Number of modules
	4 106 06		30	63	3
	4 106 08		300	63	3
1	4 106 11	Hpi Type adjustable	from 300 to 1000	63	6
	4 106 12		from 300 to 1000	125	6
1	4 106 24	AC Type	Sensitivity (mA)	Nominal rating In (A)	Number of modules
	4 106 28		30	125	6
			300	125	6
1	4 106 36	Hpi Type	30	63	3
	4 106 37		30	125	6
	4 106 40		300	63	3
1	4 106 43	Hpi Type adjustable	from 300 to 1000	63	6
	4 106 44		from 300 to 1000	125	6
1	4 106 57	4-pole 400 V\sim - Metering	LCD display	For displaying active energy, instantaneous power and current per phase (A) consumption	
	4 106 58	Hpi type with integrated energy meter	Sensitivity (mA)	Nominal rating (A)	Number of modules
			30 à 3000	63	7.5
1	4 106 59	4-pole 400 V\sim - Measurement	LCD display	For displaying current per phase, voltage, frequency, active and reactive power, power factor, active and reactive energy consumption and harmonics	
		Hpi type with integrated measurement unit	Sensitivity (mA)	Nominal rating (A)	Number of modules
			30 à 3000	125	7.5

Add-on modules DX³

Compatibility MCBs/add-on modules

Breaking capacity	Curve	Number of poles	Add-on module for 1 module/pole MCBs	Add-on module for 1.5 module/pole MCBs
6000 / 10 kA	B, C, D	2P, 3P, 4P	All range	-
10000 / 16 kA	B, C, D	2P, 3P, 4P	In ≤ 63 A	In ≥ 80 A
		3P, 4P	In ≤ 25 A	In ≥ 32 A
25 kA	B, C, Z	2P	In ≤ 32 A	In ≥ 40 A
		3P, 4P	In ≤ 10 A	In ≥ 12,5 A
	D	2P	In ≤ 25 A	In ≥ 32 A
36kA, 50 kA	B, C, D	2P, 3P, 4P	-	All range

Adjustable add-on modules, Hpi type

Easy to access settings on front panel with sealable transparent cover
Sensitivity: 300, 500 and 1000 mA
Time delay: instantaneous, selective (60 ms) or delayed (150 ms)



Hpi add-on modules with integrated metering unit or measurement control unit

Conform to standards EN 61009-1, EN 60947-2 and 61557-12 (PMD/DD/K55)

Electronic settings on the front panel
Sensitivity: 30, 300, 1000, 3000 mA
Time delay: instantaneous, or delayed (300 ms, 1 s, 3 s)

For integration in the EMDX³ display and supervision system with interface Cat.No 4 210 75 (p. 85), to feed back information and the status of the remote MCB.

Precision: EN 61557-12 Class 1

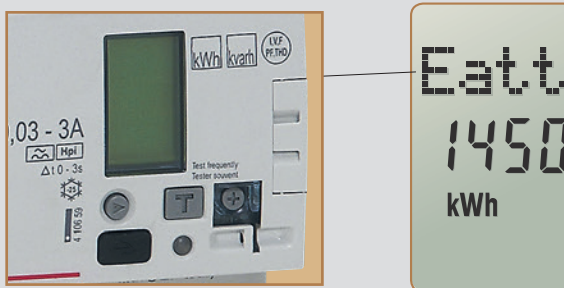

For detailed dimensions, **see e-catalogue**



Performance of MCBs and auxiliaries

Breaking capacity in IT neutral earthing system

MCB single pole breaking capacity at 400 V according to IEC 60947-2

DX ³ 6000 10 kA	1P/2P/3P/4P	3 kA
DX ³ 10000 16 kA	1P/2P/3P/4P	4 kA
DX ³ 25 kA	1P/2P/3P/4P	6.25 kA
DX ³ 50 kA	1P/2P/3P/4P	12.5 kA

Breaking capacity in the event of short-circuit to earth and insulation voltage

	1P/2P/3P/4P 230/400 V~ MCBs			
	DX ³ 6000 10 kA	DX ³ 10000 16 kA	DX ³ 25 kA	DX ³ 50 kA
I _{cn1}	10000 A	16000 A	25000 A	50000 A
U _i	500 V	500 V	500 V	500 V

I_{cn1}: Breaking capacity on 1 pole for multipole MCBs in the event of short-circuit to earth
U_i: Rated insulation voltage

Terminal connection cross-sections (mm²)

Copper cable	Rigid		Flexible	
	DX ³ 6000 10 kA	DX ³ 10000 16 kA	DX ³ 25 kA	DX ³ 50 kA
DX ³ 6000 10 kA	35	25		
DX ³ 10000 16 kA	70	50		
DX ³ 25 kA			50	35
DX ³ 36 kA, DX ³ 50 kA and add-on modules				
Auxiliaries	2.5	2.5		

MCB tripping curves

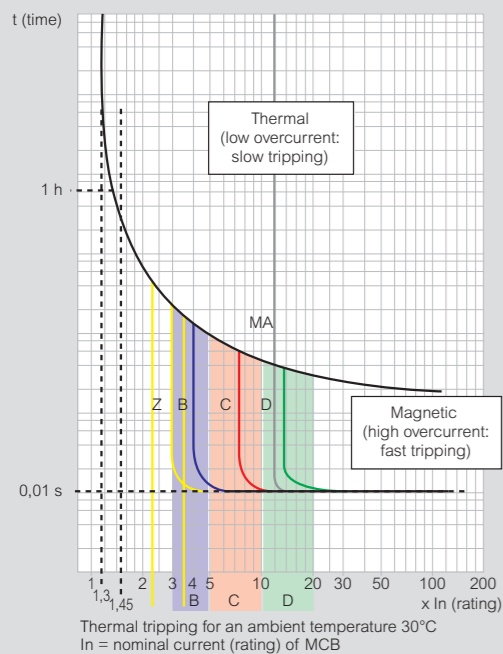

Curves	Magnetic threshold settings
Z ⁽¹⁾	2.4 to 3.6 I _n
B	3 to 5 I _n
C	5 to 10 I _n
D	10 to 14 I _n (10 to 20 acc. to the stds)
MA ⁽¹⁾	12 to 14 I _n

1: On request

Technical characteristics of auxiliaries

Max. connection cross-section: 2.5 mm²
Operating temperature: - 25°C to + 70°C

Shunt trips

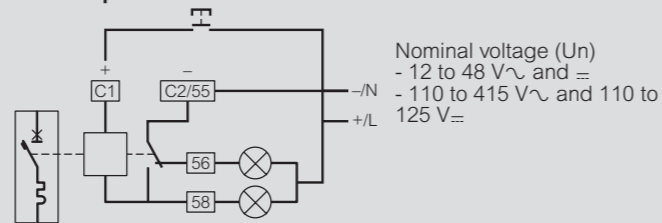

Equipped with a signalling contact which indicates tripping of the shunt trip and automatically breaks the coil.
Min. and max. voltage: 0.7 to 1.1 U_n
Tripping time: less than 20 ms
Power consumption: at 1.1 x 48 V = 121 VA
at 1.1 x 415 V = 127 VA
Impedance: 12 to 48 V = 23 Ω
110 to 415 V = 1640 Ω

Consumption	U _{min.}	U _{max.}
12 to 48 V	522 mA	2610 mA
110 to 415 V	69 mA	259 mA

Undervoltage releases

Pull-in voltage ≥ 0.55 U_n
Tripping time: 100 to 400 ms ± 10% (adjustable)
Power consumption: 24 V~ and =: 0.1 VA
48 V~ and =: 0.2 VA
230 V~: 1 VA

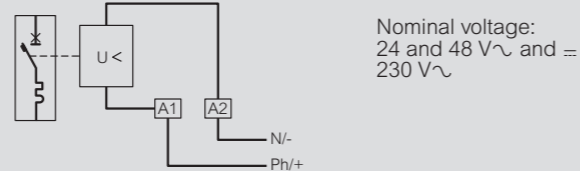

Stand-alone releases for N/C push-buttons

Min. and max. operating voltage: 196 to 250 V~
Power consumption: 1.4 VA

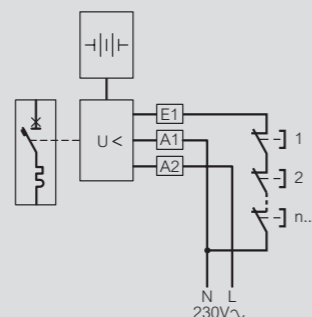

Signalling auxiliaries

U_{min.}: 24 V~ and I_{min.}: 5 mA

Compatibility between auxiliaries on 1 module/pole devices

1 module / pole device (auxiliary on the left side)	1st auxiliary	2nd auxiliary	3rd auxiliary
1st auxiliary	4 062 .. 50/52/56/58/60/62/66/76/78/80/82/84/86/87	-	-
2nd auxiliary	4 062 .. 50/52/56/58/60/62/64/66/	4 062 .. 50/52/56/58/60/62/76/78/80/82/84/86/87	-
3rd auxiliary	4 062 .. 50/52/56/58/60/62	4 062 .. 50/52/56/58/60/62	4 062 .. 76/78/80/82/84/86/87

Compatibility between auxiliaries on 1.5 module/pole devices

1.5 module / pole device (auxiliary on the left side)	1st auxiliary	2nd auxiliary	3rd auxiliary
1st auxiliary	4 062 .. 50/52/56/58/60/62/66/76/78/80/82/84/86/87	-	-
2nd auxiliary	4 062 .. 50/52/56/58/60/62	4 062 .. 50/52/56/58/60/62/	-
3rd auxiliary	4 062 .. 64/66/	4 062 .. 50/52/56/58/60/62/64/66/76/78/80/82/84/86/87	4 062 .. 76/78/80/82/84/86/87

Performance of add-on modules

AC type - Standard applications

Detection of 50-60 Hz AC residual currents

A type - Specific applications: dedicated lines

In addition to the characteristics of AC type add-on modules, A type add-on modules also detect residual currents with DC components. They are used whenever the fault currents are not sinusoidal. They are particularly suitable for the following dedicated line applications:

- On circuits where class 1 equipment may produce fault currents with DC components, such as variable speed drives with frequency inverter, etc.

Hpi type - Special applications

Hpi add-on modules, with additional immunity to false tripping, which is much higher than the level required by the standard, detect residual currents with AC and DC components (A type), operate between - 25°C and + 40°C, and are used in the following special cases:

- When loss of data would be detrimental, such as computer equipment power supply lines (banks, military instrumentation, airline reservation centres, etc.)
- When loss of operation would be detrimental (automated machines, medical instrumentation, freezer lines, etc.)

- In places where there is a high risk of lightning strikes

- On sites with lines subject to considerable interference (use of fluorescent lights, etc)
- On sites with very long lines

Special case of continuity of service

In certain locations where no staff are present and in which continuity of service is particularly important, false tripping of MCBs is not permitted (isolated telephone/TV or radio substations, pumping stations, etc.)

Combining an Hpi RCBO with a motorised control and a STOP & GO recloser provides optimum continuity of service

B type

In addition to the characteristics of A type RCDs, B type RCDs also detect smooth DC residual currents

They are used whenever fault currents are not sinusoidal. They are particularly suitable for the following specific applications: speed drives and inverters for supplying motors for pumps, lifts, textile machines, machine tools, photovoltaic installations, call centres, medical equipment, etc.

Average residual current performance curves

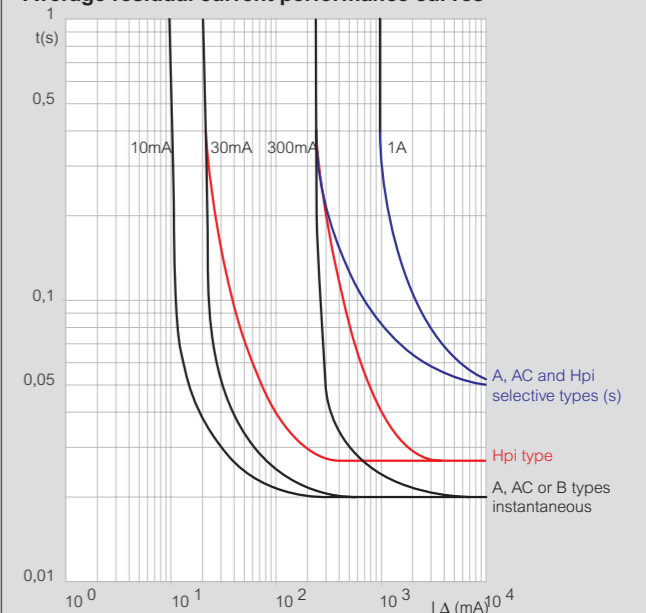

Residual current breaking capacity of DX³ add-on modules

I_{Δm} according to EN 61009-1
AC, A and Hpi add-on modules

DX ³ add-on modules used with an MCB	I _{Δm}
DX ³ (1 mod./pole)	6000 A
DX ³ (1.5 mod./pole)	30000 A

Selectivity tables

MCBs/MCBs (in A)

Upstream MCB		RX ² 6000 TX ² 6000 / TX ² 10000 DX ² 6000 - 10 kA / DX ² 10000 - 16 kA B curve										RX ² 4500 / RX ² 6000 TX ² 6000 / TX ² 10000 DX ² 6000 - 10 kA / DX ² 10000 - 16 kA C curve				DX ² 6000 - 10 kA D curve				DX ² 25 kA / DX ² 50 kA C curve					DX ² 25 kA / DX ² 50 kA D curve					
Downstream MCB	In (A)	32	40	50	63	32	40	50	63	80	100	125	32	40	50	63	32	40	50	63	80	100	125	32	40	50	63	80	100	125
RX ² 4500 RX ² 6000 B & C curves	6	128	160	200	252	240	300	375	472	1300	1600	2000	384	480	600	756	240	300	375	472	1300	1600	2000	384	480	600	756	2000	2400	3000
	10	128	160	200	252	240	300	375	472	1150	1450	1800	384	480	600	756	240	300	375	472	1150	1450	1800	384	480	600	756	1750	2150	2700
	13	128	160	200	252	240	300	375	472	1000	1300	1600	384	480	600	756	240	300	375	472	1000	1300	1600	384	480	600	756	1500	2000	2400
	16	128	160	200	252	240	300	375	472	950	1200	1500	384	480	600	756	240	300	375	472	950	1200	1500	384	480	600	756	1400	1800	2200
	20	128	160	200	252	240	300	375	472	900	1100	1400	384	480	600	756	240	300	375	472	900	1100	1400	384	480	600	756	1350	1650	2100
	25	128	160	200	252	240	300	375	472	850	1000	1300	384	480	600	756	240	300	375	472	850	1000	1300	384	480	600	756	1300	1500	2000
	32	128	160	200	252	240	300	375	472	750	950	1200	384	480	600	756	240	300	375	472	750	950	1200	384	480	600	756	1100	1450	1800
TX ² 6000 TX ² 10000 B & C curves	40	128	160	200	252	240	300	375	472	700	850	1100	384	480	600	756	240	300	375	472	700	850	1100	384	480	600	756	1000	1250	1650
	50	128	160	200	252	240	300	375	472	650	800	1000	384	480	600	756	240	300	375	472	650	800	1000	384	480	600	756	950	1200	1500
	63	128	160	200	252	240	300	375	472	650	800	1000	384	480	600	756	240	300	375	472	650	800	1000	384	480	600	756	950	1200	1500
	≤ 6	128	160	200	252	240	300	375	472	4000	T	T	384	480	600	756	700	1200	1500	3000	4000	T	T	700	1200	1500	3000	4000	T	T
	10	128	160	200	252	240	300	375	472	3000	5000	T	384	480	600	756	500	700	1000	1800	3000	5000	T	500	700	1000	1800	3000	5000	T
	13	128	160	200	252	240	300	375	472	2500	4000	6000	384	480	600	756	400	600	1200	1500	2500	4000	6000	400	600	1200	1500	2500	4000	6000
	16	128	160	200	252	240	300	375	472	2000	3600	5500	384	480	600	756	300	500	700	1000	2000	3600	5500	384	480	600	756	2000	3600	5500
DX ² 6000 - 10 kA B, C & D curves	20	128	160	200	252	240	300	375	472	1600	3000	4000	384	480	600	756	300	400	500	1000	1600	3000	4000	384	480	600	756	1600	3000	4000
	25	128	160	200	252	240	300	375	472	1300	2400	3300	384	480	600	756	240	400	500	800	1300	2400	3300	384	480	600	756	1300	2400	3300
	32	128	160	200	252	240	300	375	472	1000	1800	2700	384	480	600	756	240	400	500	600	1000	1800	2700	384	480	600	756	1100	1450	2700
	40	128	160	200	252	240	300	375	472	800	1600	2400	384	480	600	756	240	400	500	600	800	1600	2400	384	480	600	756	1000	1250	2400
	50	128	160	200	252	240	300	375	472	800	900	1700	384	480	600	756	240	400	500	600	800	900	1700	384	480	600	756	950	1200	1700
	63	128	160	200	252	240	300	375	472	650	900	1200	384	480	600	756	240	400	500	600	650	900	1200	384	480	600	756	950	1200	1500
	80	128	160	200	252	240	300	375	472	600	750	1000	384	480	600	756	240	400	500	600	600	750	1000	384	480	600	756	950	1200	1500
	100	128	160	200	252	240	300	375	472	600	750	1000	384	480	600	756	240	400	500	600	600	750	1000	384	480	600	756	950	1200	1500
	125	128	160	200	252	240	300	375	472	600	750	1000	384	480	600	756	240	400	500	600	600	750	1000	384	480	600	756	950	1200	1500
	DX ² 10000 - 16 kA B & C curves	≤ 6	128	160	200	252	240	300	375	472	4000	T	T	384	480	600	756	700	1200	1500	3000	4000	T	T	700	1200	1500	3000	4000	T
10		128	160	200	252	240	300	375	472	3000	5000	T	384	480	600	756	500	700	1000	1800	3000	5000	T	500	700	1000	1800	3000	5000	T
16		128	160	200	252	240	300	375	472	2000	3600	5500	384	480	600	756	300	500	700	1300	2000	3600	5500	384	480	600	756	2000	3600	5500
20		128	160	200	252	240	300	375	472	1600	3000	4000	384	480	600	756	300	400	500	1000	1600	3000	4000	384	480	600	756	1600	3000	4000
25		128	160	200	252	240	300	375	472	1300	2400	3300	384	480	600	756	240	400	500	800	1300	2400	3300	384	480	600	756	1300	2400	3300
32		128	160	200	252	240	300	375	472	1000	1800	2700	384	480	600	756	240	400	500	600	1000	1800	2700	384	480	600	756	1100	1450	2700
40		128	160	200	252	240	300	375	472	800	1600	2400	384	480	600	756	240	400	500	600	800	1600	2400	384	480	600	756	1000	1250	2400
50		128	160	200	252	240	300	375	472	800	900	1700	384	480	600	756	240	400	500	600	800	900	1700	384	480	600	756	950	1200	1700
63		128	160	200	252	240	300	375	472	650	900	1200	384	480	600	756	240	400	500	600	650	900	1200	384	480	600	756	950	1200	1500
80		128	160	200	252	240	300	375	472	600	750	1000	384	480	600	756	240	400	500	600	600	750	1000	384	480	600	756	950	1200	1500
100	128	160	200	252	240	300	375	472	600	750	1000	384	480	600	756	240	400	500	600	600	750	1000	384	480	600	756	950	1200	1500	
DX ² 10000 - 16 kA D curve	≤ 6	128	160	200	252	240	300	375	472	4000	T	T	384	480	600	756	700	1200	1500	3000	4000	T	T	700	1200	1500	3000	4000	T	T
	10	128	160	200	252	240	300	375	472	3000	5000	T	384	480	600	756	500	700	1000	1800	3000	5000	T	500	700	1000	1800	3000	5000	T
	16	128	160	200	252	240	300	375	472	2000	3600	5500	384	480	600	756	300	500	700	1300	2000	3600	5500	384	480	600	756	2000	3600	5500
	20	128	160	200	252	240	300	375	472	1600	3000	4000	384	480	600	756	300	400	500	1000	1600	3000	4000	384	480	600	756	1600	3000	4000
	25	128	160	200	252	240	300	375	472	1300	2400	3300	384	480	600	756	240	400	500	800	1300	2400	3300	384	480	600	756	1300	2400	3300
	32	128	160	200	252	240	300	375	472	1000	1800	2700	384	480	600	756	240	400	500	600	1000	1800	2700	384	480	600	756	1100	1450	2700
	40	128	160	200	252	240	300	375	472	800	1600	2400	384	480	600	756	240	400	500	600	800	1600	2400	384	480	600	756	1000	1250	2400
	50	128	160	200	252	240	300	375	472	800	900	1700	384	480	600	756	240	400	500	600	800	900	1700	384	480	600	756	950	1200	1700
	63	128	160	200	252	240	300	375	472	650	900	1200	384	480	600	756	240	400	500	600	650	900	1200	384	480	600	756	950	1200	1500
	80	128	160	200	252	240	300	375	472	600	750	1000	384	480	600	756	240	400	500	600	600	750	1000	384	480	600	756	950	1200	1500
100	128	160	200	252	240	300	375	472	600	750	1000	384	480	600	756	240	400	500	600	600	750	1000	384	480	600	756	950	1200	1500	
DX ² 25 kA C curve	≤ 6																													

Back up between MCCBs and MCBs (in kA)

In 3 phases networks + N 400/415 V according to IEC 60947-2

MCBs/MCCBs upstream		DX ³ 10000 16 kA B, C and D curves	DX ³ 25 kA C and D curves	DX ³ 50 kA C and D curves	DPX ³ 160				DPX ³ 250				DPX 250	DPX-H 250	DPX 630	DPX-H 630 DPX-L 630 - 100 kA	DPX 1250 and 1600 + DPX-H 1250 and 1600
MCBs downstream		10 to 125 A	10 to 125 A	10 to 63 A	16 kA 16 to 160 A	25 kA 16 to 160 A	36 kA 16 to 160 A	50 kA 16 to 160 A	25 kA 40 to 250 A	36 kA 40 to 250 A	50 kA 40 to 250 A	70 kA 40 to 250 A	36 kA 40 to 250 A	70 kA 40 to 250 A	36 kA 250 to 630 A	70 kA 250 to 630 A	50 kA and 70 kA 630 to 1600 A
DX ³ 6000 - 10 kA B, C and D curves	≤ 20 A	16 kA	25 kA	50 kA	16 kA	25 kA	25 kA	25 kA	25 kA	25 kA	25 kA	25 kA	25 kA	25 kA	25 kA	25 kA	25 kA
	25 A	16 kA	25 kA	50 kA	16 kA	25 kA	25 kA	25 kA	25 kA	25 kA	25 kA	25 kA	25 kA	25 kA	25 kA	25 kA	20 kA
	32 A	16 kA	25 kA	50 kA	16 kA	25 kA	25 kA	25 kA	25 kA	25 kA	25 kA	25 kA	25 kA	25 kA	25 kA	25 kA	15 kA
	40 A	16 kA	25 kA	50 kA	16 kA	25 kA	25 kA	25 kA	25 kA	25 kA	25 kA	25 kA	25 kA	25 kA	20 kA	20 kA	15 kA
	50 A	16 kA	25 kA	50 kA	16 kA	25 kA	25 kA	25 kA	25 kA	25 kA	25 kA	25 kA	25 kA	25 kA	16 kA	16 kA	12,5 kA
63 A	16 kA	25 kA	-	16 kA	25 kA	25 kA	25 kA	25 kA	25 kA	25 kA	25 kA	25 kA	20 kA	16 kA	16 kA	12,5 kA	
DX ³ 10000 - 16 kA B, C and D curves	≤ 20 A	-	25 kA	50 kA	-	25 kA	25 kA	25 kA	25 kA	25 kA	25 kA	25 kA	25 kA	25 kA	25 kA	25 kA	25 kA
	25 A	-	25 kA	50 kA	-	25 kA	25 kA	25 kA	25 kA	25 kA	25 kA	25 kA	25 kA	25 kA	25 kA	25 kA	20 kA
	32 A	-	25 kA	50 kA	-	25 kA	25 kA	25 kA	25 kA	25 kA	25 kA	25 kA	25 kA	25 kA	25 kA	25 kA	16 kA
	40 A	-	25 kA	50 kA	-	25 kA	25 kA	25 kA	25 kA	25 kA	25 kA	25 kA	25 kA	25 kA	20 kA	20 kA	16 kA
	50 A	-	25 kA	50 kA	-	25 kA	25 kA	25 kA	25 kA	25 kA	25 kA	25 kA	25 kA	20 kA	20 kA	16 kA	
	63 A	-	25 kA	-	-	25 kA	25 kA	25 kA	25 kA	25 kA	25 kA	25 kA	25 kA	20 kA	20 kA	20 kA	16 kA
DX ³ 25 kA C curve	≤ 25 A	-	-	50 kA	-	-	36 kA	36 kA	-	36 kA	36 kA	25 kA	30 kA	30 kA	30 kA	30 kA	30 kA
	32 to 50 A	-	-	50 kA	-	-	36 kA	36 kA	-	36 kA	36 kA	25 kA	36 kA	36 kA	36 kA	36 kA	36 kA
	63 to 80 A	-	-	-	-	-	36 kA	36 kA	-	36 kA	36 kA	36 kA	36 kA	36 kA	36 kA	36 kA	36 kA
	100 et 125 A	-	-	-	-	-	36 kA	36 kA	-	36 kA	36 kA	36 kA	36 kA	36 kA	36 kA	30 kA	30 kA
DX ³ 25 kA D curve	≤ 10 A	-	-	50 kA	-	-	36 kA	36 kA	-	36 kA	36 kA	36 kA	30 kA	30 kA	30 kA	30 kA	30 kA
	16 to 63 A	-	-	50 kA	-	-	36 kA	36 kA	-	36 kA	36 kA	36 kA	36 kA	36 kA	36 kA	36 kA	36 kA
DX ³ 50 kA C and D curves	10 to 63 A	-	-	-	-	-	-	-	-	-	-	70 kA	-	70 kA	-	70 kA	70 kA

In 3 phases networks + N 230/240 V according to IEC 60947-2

MCBs/MCCBs upstream		DX ³ 10000 16 kA B, C and D curves		DX ³ 25 kA C and D curves		DX ³ 50 kA C curves		DX ³ 50 kA D curves		DPX ³ 160				DPX ³ 250				DPX 250	DPX-H 250	DPX 630	DPX-H 630 DPX-L 630 - 100 kA	DPX 1250 and 1600 + DPX-H 1250 and 1600		
MCBs downstream		≤ 32 A	40 to 125 A	≤ 32 A	40 to 125 A	≤ 32 A	40 to 63 A	≤ 32 A	40 to 63 A	16 kA 16 to 160 A	25 kA 16 to 160 A	36 kA 16 to 160 A	50 kA 16 to 160 A	25 kA 40 to 250 A	36 kA 40 to 250 A	50 kA 40 to 250 A	70 kA 40 to 250 A	36 kA 40 to 250 A	70 kA 40 to 250 A	36 kA 250 to 630 A	70 kA 250 to 630 A	50 kA + 70 kA 630 to 1600 A		
DX ³ 6000 - 10 kA B, C and D curves	≤ 20 A	32 kA	25 kA	50 kA	25 kA	50 kA	50 kA	50 kA	50 kA	28 kA	40 kA	50 kA	50 kA	40 kA	50 kA	50 kA	50 kA	50 kA	50 kA	50 kA	50 kA	50 kA	50 kA	50 kA
	25 to 40 A	-	25 kA	-	25 kA	-	50 kA	-	50 kA	28 kA	40 kA	50 kA	50 kA	40 kA	50 kA	50 kA	50 kA	50 kA	50 kA	50 kA	50 kA	50 kA	50 kA	50 kA
	50 A	-	25 kA	-	25 kA	-	-	-	-	28 kA	40 kA	50 kA	50 kA	40 kA	50 kA	50 kA	50 kA	50 kA	50 kA	50 kA	50 kA	30 kA	30 kA	25 kA
	63 A	-	25 kA	-	25 kA	-	-	-	-	28 kA	40 kA	50 kA	50 kA	40 kA	50 kA	50 kA	50 kA	50 kA	50 kA	50 kA	50 kA	30 kA	30 kA	25 kA
DX ³ 10000 - 16 kA B, C and D curves	≤ 20 A	-	-	50 kA	32 kA	70 kA	70 kA	70 kA	70 kA	35 kA	40 kA	50 kA	50 kA	40 kA	50 kA	50 kA	50 kA	50 kA	50 kA	50 kA	50 kA	50 kA	50 kA	50 kA
	25 to 40 A	-	-	-	32 kA	-	70 kA	-	70 kA	35 kA	40 kA	50 kA	50 kA	40 kA	50 kA	50 kA	50 kA	50 kA	50 kA	50 kA	50 kA	50 kA	50 kA	50 kA
	50 et 63 A	-	-	-	32 kA	-	-	-	-	35 kA	40 kA	50 kA	50 kA	40 kA	50 kA	50 kA	50 kA	50 kA	50 kA	50 kA	50 kA	36 kA	36 kA	36 kA
	80 to 125 A	-	-	-	-	-	-	-	-	35 kA	40 kA	50 kA	50 kA	40 kA	50 kA	50 kA	50 kA	50 kA	50 kA	50 kA	50 kA	32 kA	32 kA	32 kA
DX ³ 25 kA C and D curves	≤ 25 A	-	-	-	-	70 kA	70 kA	70 kA	70 kA	-	-	-	55 kA	-	-	60 kA	60 kA	55 kA	60 kA	55 kA	60 kA	55 kA	60 kA	50 kA
	32 to 125 A	-	-	-	-	-	70 kA	-	70 kA	-	-	-	65 kA	-	-	60 kA	60 kA	55 kA	60 kA	55 kA	60 kA	60 kA	50 kA	
DX ³ 25 kA D curves	≤ 10 A	-	-	-	-	70 kA	70 kA	70 kA	70 kA	-	-	-	55 kA	-	-	60 kA	60 kA	55 kA	60 kA	55 kA	60 kA	55 kA	60 kA	50 kA
	16 to 63 A	-	-	-	-	70 kA	70 kA	70 kA	70 kA	-	-	-	65 kA	-	-	60 kA	60 kA	55 kA	60 kA	55 kA	60 kA	60 kA	50 kA	
DX ³ 50 kA C and D curves	10 to 63 A	-	-	-	-	-	-	-	-	-	-	-	-	-	-	-	-	120 kA	-	120 kA	-	120 kA	120 kA	

TT or TN neutral earthing systems:
For a 230/400 V supply in order to determine the breaking capacity of a 2 P MCB used as L + N (230 V) downstream a 2 P or 4 P circuit breaker use values indicated in the table for 230/240 V

Protection of DC circuits

Protection of DC circuits

DX³ MCBs (1P/2P/3P/4P - I_n ≤ 63 A) designed for use in 230/400 V~ supplies, can also be used in DC circuits. In this case, the following deratings and precautions must be taken into account

1 - Protection against short-circuits

Max. magnetic tripping threshold: multiplied by 1.4
 Example: For a C curve MCB for which the AC tripping threshold is between 5 and 10 I_n, the DC tripping threshold will be between 7 and 14 I_n

2 - Protection against overloads

The time/current thermal tripping curve is the same as for AC

3 - Operating voltage

Min. operating voltage: 12 V_{DC}
 Max. operating voltage: 60 V_{DC} for single-pole MCBs
 For voltages higher than this value, several poles must be wired in series as follows

Number of poles	1 P	2 P	3 P	4 P
Max. operating voltage (V)	60	110	150	180

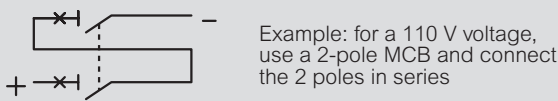

4 - Wiring modes

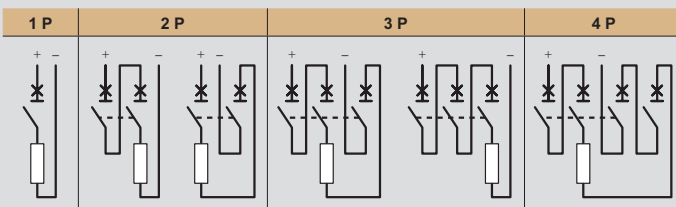

5 - Breaking capacity

According to IEC 60947.2		DC Voltage (V)	1P	2P	3P	4P
DX ³ 4500 / 6 kA B and C curves I _n ≤ 63 A	I _{cu}	12 to 60	4.5 kA	4.5 kA	4.5 kA	4.5 kA
		110		4.5 kA	4.5 kA	4.5 kA
		150			4.5 kA	4.5 kA
	I _{cs} ⁽¹⁾	12 to 60	100%	100%	100%	100%
		110		100%	100%	100%
		150			100%	100%
DX ³ 6000 / 10 kA B and C curves I _n ≤ 63 A	I _{cu}	12 to 60	6 kA	6 kA	6 kA	6 kA
		110		6 kA	6 kA	6 kA
		150			6 kA	6 kA
	I _{cs} ⁽¹⁾	12 to 60	100%	100%	100%	100%
		110		100%	100%	100%
		150			100%	100%
DX ³ 10000 / 16 kA B and C curves I _n ≤ 63 A	I _{cu}	12 to 60	10 kA	10 kA	10 kA	10 kA
		110		10 kA	10 kA	10 kA
		150			10 kA	10 kA
	I _{cs} ⁽¹⁾	12 to 60	100%	100%	100%	100%
		110		100%	100%	100%
		150			100%	100%
DX ³ 25 kA B and C curves I _n ≤ 25 A	I _{cu}	12 to 60	16 kA	16 kA	16 kA	16 kA
		110		16 kA	16 kA	16 kA
		150			16 kA	16 kA
	I _{cs} ⁽¹⁾	12 to 60	100%	100%	100%	100%
		110		100%	100%	100%
		150			100%	100%
		180			100%	100%

1: As a % of I_{cu}

6 - Distribution of breaking poles

To choose the MCB and determine the pole distribution necessary for breaking on each of the polarities, it is necessary to know how the installation is earthed

• Supply with one polarity earthed:

Place all the poles necessary for breaking on the other polarity. If isolation is required, an additional pole must be added on the earthed polarity

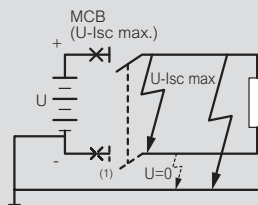

Example: circuit earthed via the negative polarity / U = 110 V_{DC} / I_{sc} = 10 kA / I_n = 32 A

Protect the positive polarity using an MCB capable of breaking 10 kA at 110 V (DX³ 10000 2P 32 A with 2 poles on the positive polarity)
 For isolation, use a DX³ 10000 3P 32 A with 2 poles on the positive polarity and one pole on the negative polarity

DX ³ 10000 / 16 kA	DC Voltage (V)	1P	2P	3P	4P	
Acc. To IEC 60947.2	I _{cu}	12 to 60	10 kA	10 kA	10 kA	10 kA
		110		10 kA	10 kA	10 kA
		150			10 kA	10 kA
		180				10 kA

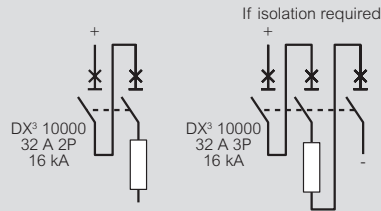

• Network earthed via a middle point:

Place on each polarity the number of poles necessary for max. I_{sc} breaking at half voltage

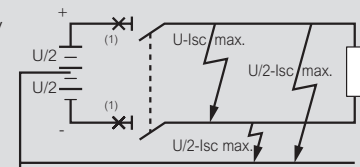

Example:

Circuit earthed via a middle point / U = 220 V_{DC} / I_{sc} = 6 kA / I_n = 10 A
 Protect each polarity using an MCB capable of breaking 6 kA at half voltage, i.e. 110 V (DX³ 6000 4P 10 A with 2 poles on each polarity)

DX ³ 6000 / 10 kA	DC Voltage (V)	1P	2P	3P	4P	
Acc. To IEC 60947.2	I _{cu}	12 to 60	6 kA	6 kA	6 kA	6 kA
		110		6 kA	6 kA	6 kA
		150			6 kA	6 kA
		180				6 kA

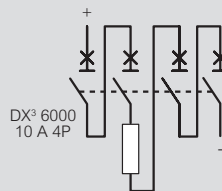

• Isolated earth supply:

Distribute the poles necessary for breaking over the 2 polarities to provide protection in the event of a double earth fault (particularly if there are a number of circuits in parallel)

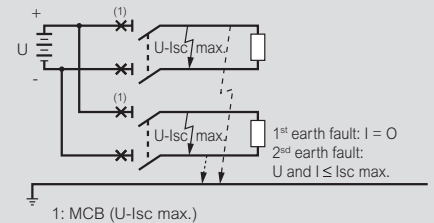

Example: isolated earth circuit / U = 48 V_{DC} / I_{sc} = 6 kA / I_n = 40 A
 Protect the installation with an MCB capable of breaking 6 kA at 48 V and protect each polarity (DX³ 6000 MCB 2P 40 A with one pole on each polarity)

DX ³ 6000 / 10 kA	DC Voltage (V)	1P	2P	3P	4P	
Acc. To IEC 60947.2	I _{cu}	12 to 60	6 kA	6 kA	6 kA	6 kA
		110		6 kA	6 kA	6 kA
		150			6 kA	6 kA
		180				6 kA

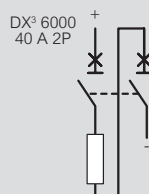

Dimensions of din-rail equipment

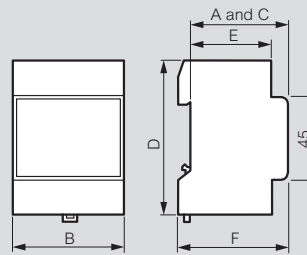
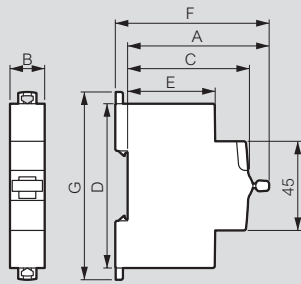

Product	A		B				C	D	E	F	G
	1P	1P+ N	2P	3P	4P						
RX³ MCBs	71.7	17.7	35.4	35.4	53.1	70.8	61	83	44	77.8	88.9
RX³ RCCBs	71.7			35.6		71.2	61	83	44	77.8	88.9
TX³ MCBs	71.7	17.7	35.4	35.4	53.1	70.8	61	83	44	77.8	88.9
TX³ RCCBs	71.7			35.6		71.2	61	83	44	77.8	88.9
Isolating switches DX³	71.7	17.8		17.8/ 35.4	35.6/ 53.1	70.8	61	83	44	77.8	94.8
Remote trip head isolating switches DX³ up to 63A - 1 mod/pole	71.7			35.4	53.1	70.8	61	83	44	77.9	94.8
Remote trip head isolating switches DX³ 100/125A - 1.5 mod/pole	73				80.1	106.8	61	96	47	79	104.3
DX³ RCCBs	71.7			35.6		71.2	61	83	44	77.8	94.8
1P DX³ RCBOs (up to 45A)	68	17.7					60	115	48	74	126.8
1P+N DX³ RCBOs (up to 40A) & 4P (up to 32A)	71.7		35.6			71.2	61	83	44	77.8	94.8
2P & 4P DX³ RCBOs (40A to 63A)	72			71.2		124.6	61	96	44	78.2	107.8
1P+N DX³ MCBs 1 mod	71.7		17.8				61	83	44	77.8	94.8
DX³ MCBs - 1 mod/pole	71.7	17.7	35.4	35.4	53.1	70.8	61	83	44	77.8	94.8
DX³ MCBs - 1,5 mod/pole	73.1	26.7		53.4	80.1	106.8	61	100	47	79	104.3
DX³ add-on modules up to 63A - 1 mod/pole	72			35.6	53.4	53.4	61	96	44	78.2	107.8
DX³ add-on modules up to 63A - 1.5 mod/pole	72			35.6	53.4	53.4	61	96	47	78.2	116.7
DX³ add-on modules 80 to 125A - 1.5 mod/pole	72			71.2	106.8	106.8	61	114	47	78.2	129
DX³ auxiliaries	71.5			8.8 / 17.7			61	83	44	77.7	84.5
DX³ remote control	74.3			17.7 / 35.4			61	83	44	80.5	98.8
DX³ Stop&Go automatic resetting	74.3			35.4			61	83	44	80.5	113.7
Change-over switches	68	17.7		35.6			60	83	44	74	94
CX³ latching relays	64	17.8		17.8	35.6	35.6	61	84.5	44	70.2	94.8
CX³ contactors up to 25A	66.3/ 61	17.8		17.8	35.6	35.6	61	84.5	44	72.6/ 67.3	94.8
CX³ contactors 40A & 63A	62			35.6	53.4	53.4	60	83	44	68	94
Auxiliaries for CX³ contactors and latching relays	61			9/17.8			61	84.5	44	67	84.5
Push-buttons / control switches	68			17.7			60	83	44	74	94
Indicators	68			17.7			60	83	44	69	94
Bells and buzzers	60			17.7			60	76	44	66	85
Light sensitive switches											
Cat.Nos 0 037 21, 4 126 23	60			35.6			60	85	37.5	66	70
Socket outlets	60			44.5			60	83	44	66	92
Time delay relays	60			17.7			60	83	44	66	94
Remote control dimmers											
Cat.No 0 036 58	60			36			60	83	44	66	94
Cat.No 0 036 60	60			72			60	83	44	66	94
Cat.No 0 036 71	60			108			60	83	44	66	94

Description	A	B	C	D	E	F
Programmable time switches						
0 037 05	60	17.8	60	83	44	66
4 127 80/90/94	60	17.8	60	83	44	66
4 127 95, 4 128 12/13	60	53	60	83	44	66
4 126 31/33/41	60	35.6	60	83	44	66
4 126 54/57	60	35.6	60	83	44	66
0 047 70	60	90	60	83	44	66
Transformers and power supplies						
0 042 10/30/31	60	72	60	83	44	66
4 130 91	60	35.8	60	83.5	44	66
4 130 92/93/96	60	71.5	60	83.5	44	66
4 130 98	60	89	60	94	44	66
0 047 91/92	60	105	60	95	44	66
4 131 05/06/07/08	60	89	60	95	44	66
0 047 93	60	70	60	95	44	66
Residual current relay						
0 260 88	60	35.5	60	89	44	66

RCD add-on module DX³ 63A - 125A with metering/measuring unit

Cat.Nos: 4 106 57 to 4 106 59



CONTENTS	PAGE
1. Description - Use.....	1
2. Range	1
3. Overall dimensions.....	2
4. Fixing – Connection.....	3
5. General characteristics.....	4
6. Compliance and approvals	9
7. Curves	10
8. Auxiliaries and accessories	11

1. DESCRIPTION - USE

RCD add-on modules with metering/measuring unit for MCBs. DX³ ≤125A, 1,5 modules per pole width, breaking capacity 10000A/16kA, 25kA, 36kA or 50kA.

They protect people against direct and indirect electric shocks and installations against insulation faults. They enable, in addition, the measurement of the main electrical quantities (depending on the version: voltage, current, residual current, power, energy, frequency, power factor, THD, the history of causes of recent trips).

Symbol:

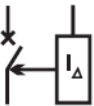

Technology:

. Electronic residual current operating.

2. RANGE

Number of poles:

. 4 poles.

Width:

. Four poles – 7,5 modules (7,5 x 17,8 mm = 133,5 mm).

Rated Currents, In:

. In 63A (cat. no 4 106 57):
. In 125 A (cat. nos 4 106 58 / 59) :

Type:

. A-Hpi: sinusoidal AC fault currents with or without DC component and immunity against unwanted tripping (Hpi type are also A types).

Sensitivities and Tripping time:

. 30 mA instantaneous.
. Adjustable sensitivity: 300ma, 1A or 3A with instantaneous or delayed tripping of 300ms, 1s or 3s.

2. RANGE (continued)

Features:

. Basic functions common to all devices:
Remote report of the data

. Specific functions of the add-on module with metering unit (cat. N° 4 106 57 / 58):

Currents L1 L2 L3 N (in A)
Residual current (in mA or A)
Instantaneous total active power L1 L2 L3 (in W or kW)
Total energy consumption (in kWh)

. Specific functions of the add-on module with measuring unit (cat. N° 4 106 59):

Currents L1 L2 L3 N (in A)
Residual current (in mA or A)
Voltages
Powers
Energies
Frequency
THD
Power factor (cos φ)
Cause of last trip

Rated Voltage / Frequency:

. 230 / 400 V~, 50 Hz standard tolerances.
. 240 / 415 V~, 50 Hz standard tolerances.

Maximum operating voltage:

. 440 V ~, 50 Hz with standard tolerances.

Minimum operating voltage:

. 170 V ~, 50 Hz with standard tolerances.

RCD add-on module DX³ 63A - 125A with metering/measuring unit

Cat.Nos: 4 106 57 to 4 106 59

2. RANGE (continued)

Compatibility with MCBs DX³:

	Breaking Capacity	Curve	4 106 57	4 106 58	4 106 59
DX ³	10000A / 16kA	B, C, D	--	$80A \leq I_n \leq 125A$	$80A \leq I_n \leq 125A$
	25kA	B, C,	$32A \leq I_n \leq 63A$	$32A \leq I_n \leq 125A$	$32A \leq I_n \leq 125A$
	25kA	D, MA	$12,5A \leq I_n \leq 63A$	$12,5A \leq I_n \leq 125A$	$12,5A \leq I_n \leq 125A$
	36kA	C	$10A \leq I_n \leq 63A$	$10A \leq I_n \leq 80A$	$10A \leq I_n \leq 80A$
	50kA	B, C, D, MA	$10A \leq I_n \leq 63A$	$10A \leq I_n \leq 63A$	$10A \leq I_n \leq 63A$

3. OVERALL DIMENSIONS

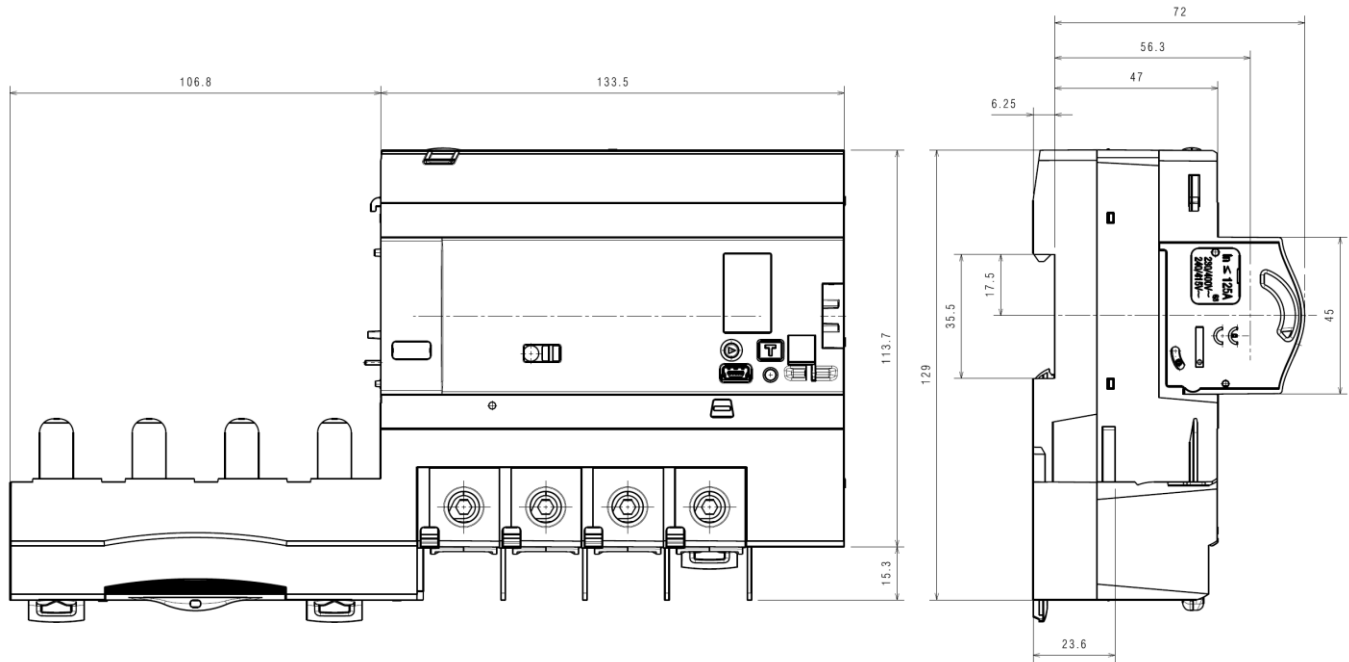

RCD add-on module DX³ 63A - 125A with metering/measuring unit

Cat.Nos: 4 106 57 to 4 106 59

4. FIXING - CONNECTION

Assembling:

. On the right side of the MCBs. DX³ ≤125A, 1.5 modules per pole width, breaking capacity 10000A/16kA, 25kA, 36kA or 50kA.. Associated to the circuit breaker by plastic clamps and tightening of connections in the downstream terminals of the MCB. Can be mounted on the right of the MCBs 1.5 modules per pole up to 63A breaking capacity 16kA, 25 kA and 50 kA, in this case the rated current of the add-on module is 63 A.

Mounting:

. On symmetrical IEC/EN 60715 rail or DIN 35 rail.

Power supply:

. From the top trough the associated MCB or from the bottom directly on the add-on module.

Operating position:

. Vertical Horizontal Upside down On the side

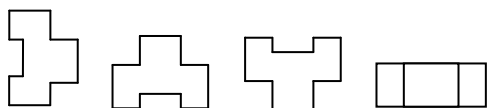

Screw terminals:

- . Terminals protected against accidental contact (IP20).
- . The screw terminals are separated by built-in shields.
- . Cage terminals, with release and captive screw
- . Add-on module In 63A:
Terminal depth: 19 mm.
Stripping length : 17 mm
Screw head: mixed, slotted and Pozidriv n°2.
Recommended tightening torque: 3 Nm.
- . Add-on module In 125A:
Terminal depth: 19 mm.
Stripping length : 17 mm
Screw head: Allen screw 4 mm.
Recommended tightening torque: 5,5 Nm.

Connectable section:

63A

. In the power terminals

	Copper cable	
	Without ferrule	With ferrule
Rigid cable	1 x 50 mm ²	-
Flexible cable	1 x 35 mm ²	1 x 35 mm ²

125A

. In the power terminals

	Copper cable	
	Without ferrule	With ferrule
Rigid cable	1 x 70 mm ²	-
Flexible cable	1 x 50 mm ²	1 x 50 mm ²

4. FIXING - CONNECTION (continued)

125A

In the automatic terminals

	Copper cable	
	Without ferrule	With ferrule
Rigid cable	0,75 mm ² + 2,5 mm ²	-
Flexible cable	0,75 mm ² + 2,5 mm ²	0,75 mm ² + 1,5 mm ²

Recommended tools:

- . For fixing on the DIN rail: flat screwdriver 5.5 mm (from 4 to 6 mm).
- . For the terminals 63A: Pozidriv n°2 screwdriver or flat screwdriver 5,5 mm (6,5 mm maxi).
- . For the terminals 125A: Allen wrench 4 mm.

Manual actuation of the add-on module:

- . By the 2-positions ergonomic handle of the associated MCB.
 - I / ON : Closed circuit.
 - O / OFF : Open circuit.

Contacts status display:

- . By marking of the associated MCB. handle:
 - “O-Off” white on a green background = contacts opened.
 - “I-On” white on a red background = contacts closed.

Report of the contacts position:

- . The MCB contacts position is available through the communication.
Possible positions : Closed / Open / Manual or on short-circuit trip / trip caused by a residual current fault

Display of fault trip caused by a residual current:

- . Yellow mechanical signaller into the window on front-side marking zone.

Signalling the state of the device:

- . Signalling by bi colour LED:
 - Green fixed: normal operation.
 - Green flashing: settings in progress.
 - Red fixed: value of the residual current (I_Δ) exceeds 45% of the set value.
 - Red flashing: value of the residual current (I_Δ) exceeds 60% of the set value.
 - Red / Green alternate flashing: Self-protection due to overheating.

Labelling:

- . Circuit identification by insertion of a label in the label holder of the associated MCB.

Battery type:

- . Lithium CR1616. Qty:2

Battery voltage:

- . 3 V d.c.

Battery current:

- . 50 mAh.

RCD add-on module DX³ 63A - 125A with metering/measuring unit

Cat.Nos: 4 106 57 to 4 106 59

5. GENERAL CHARACTERISTICS

Front face marking:

- . By permanent ink pad printing.

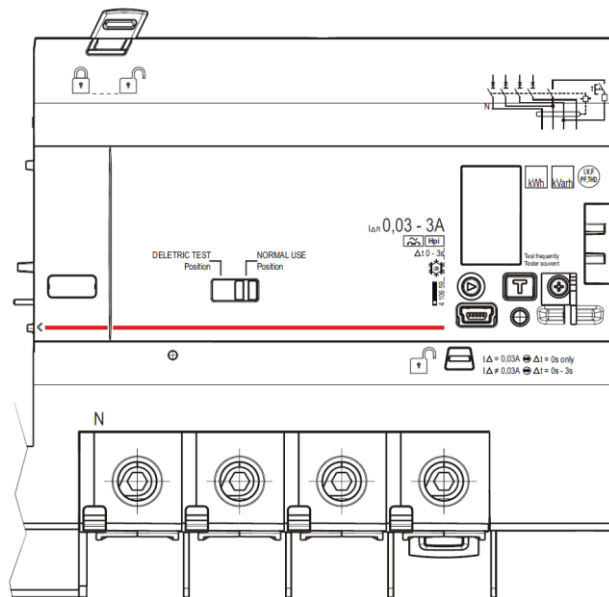

"Test" key operating voltages:

U min	170 V ~
U max	440 V ~

Residual breaking capacity I Δ m:

- . In accordance with standard IEC/EN 61009-1 and IEC/EN 60947-2 (I Δ m: short-circuit to ground)
- I Δ m = 60% of I_{cu} of the associated MCB.

Neutral system:

- . IT - TT - TN.

Insulation rated voltage:

- . U_i = 500 V according to IEC/EN 61009-1 and IEC/EN 60947-2.

Pollution degree:

- . 3.

Dielectric strength:

- . 2500 V.

Impulse-withstand rated voltage:

- . U_{imp} = 6 kV (wave 1.2 / 50 μ s).

Operation at different frequencies respect to the nominal frequency:

- . The only operating frequency is the nominal frequency.

5. GENERAL CHARACTERISTICS (continued)

Protection against unwanted tripping:

- . Damped recurrent wave - 0.5 μ s/100kHz : 200A for all sensitivity.
- . Wavw 8/20 μ s:

Sensitivity	30 mA	300 mA	1 A	3 A
Corrent	3000 A	5000 A	5000 A	5000 A

Protection class:

- . Protection index of terminals against solid and liquid bodies (wired device): IP 20 (in accordance with standards IEC/EN 60529 and NF C 20-010).
- . Protection index of the front face against direct contacts: IP 40 (in accordance with standards IEC/EN 60529 and NF C 20-010).
- . Class II compared to conductive parts.
- . Protection index against mechanical shocks: IK 01 (accordance with standards IEC / EN 50102 et NF C 20-015).

Mechanical and electrical endurance (associated to a MCB)

- . 20000 operations without load
- . 10000 operations with load.
- . 1000 tripping operations by the Test key.
- . 1000 tripping operations for fault residual current.

Power dissipated and impedance per pole at I_n:

I_n ≤ 63A

I _n	Four-Pole	
	Z(m Ω)	P(W)
6	0.55	0.02
10	0.55	0.06
16	0.55	0.14
20	0.55	0.22
25	0.55	0.34
32	0.55	0.56
40	0.55	0.88
50	0.55	1.38
63	0.55	2.18

I_n ≤ 125A

I _n	Four-Pole	
	Z(m Ω)	P(W)
80 A	0.245	1.57
100 A	0.245	2.45
125 A	0.245	3.83

Note: to obtain total power dissipated by the assembly Add-on module + MCB, these powers should be added to those of the associated MCB.

RCD add-on module DX³ 63A - 125A with metering/measuring unit

Cat.Nos: 4 106 57 to 4 106 59

5. GENERAL CHARACTERISTICS (continued)

Consumption:

. Max. 1 VA.

Plastics:

. Polycarbonate parts.

Resistance to abnormal heat and to fire:

. Fire retardant and self-extinguishing materials.
. Heat and fire resistant according to EN 61009, glow-wire test at 960°C for external parts made of insulating material necessary to retain in position current-carrying parts and parts of protective circuit (650°C for all other external parts made of insulating material).

Calorific value:

	Four-pole
MJ	8,53

Volume and quantity when packed:

. Four poles 4,6 dm³ per device.

Average weight per device:

. Four pole 63A: 0,7 kg
. Four pole 125A: 1 kg

Ambient operating temperature:

. Min. = -25°C. Max. = +60°C

Ambient storage temperature:

. Min. = -40°C. Max. = +70°C

Specific use:

. Appropriate to be used in humid environment and polluted by chlorine (pool-type)

Derating according ambient temperature:

. Reference temperature: 40 °C in accordance with standard IEC/EN 60947-2.
. No derating of the add-on module depending on the ambient temperature between - 25 ° C and +40 ° C.
. Derating between + 40 ° C to + 76 ° C :

Temperature	40 °C	50 °C	60 °C
% of I _n	100 %	95 %	90 %

Resistance to sinusoidal vibrations:

. According to IEC 60068-2-35.
. Axis : x, y, z.
. Frequency range: 5÷100 Hz ; duration 90 minutes
. Displacement (5÷13,2 Hz) : 1mm.
. Acceleration (13,2÷100 Hz) : 0,7g (g=9,81 m/s²)

5. GENERAL CHARACTERISTICS (continued)

Influence of the altitude :

	2000 m	3000 m	4000 m	5000 m
Dielectric strength	3000 V	2500 V	2000 V	1500 V
Max operating voltage	400 V	400 V	400 V	400 V
Derating at 40°C	none	none	none	none

Measured quantities and measurement accuracy class:

. Currents (accuracy class 1) :
phase: I₁, I₂, I₃ ;
neutral: I_N.
. Voltage (accuracy class 0,5) :
phase/phase: U₁₂, U₂₃, U₃₁ ;
phase/neutral: V_{1N}, V_{2N}, V_{3N}.
. Frequency (accuracy 0,1%)
. Power:
instantaneous total active power;
instantaneous total reactive power.
. Power factor (cos φ).
. Energy :
total active energy, positive and negative (accuracy class 1);
total reactive energy, positive and negative (accuracy class 2).
. THD :
THD of Voltages: V₁, V₂, V₃;
THD of currents: I₁, I₂, I₃, I_N.

Historical:

. Historical of causes of recent trips :
trip due to residual current fault (value of the residual current)
overheating (temperature value)
trip by test key

Display card:

. The display is the user interface. It consist of:

1. Backlight LCD display;
2. Navigation key;
3. USB Port;
4. RCD Test key;
5. Bi-colour LED;
6. Setting key;
7. Battery compartment

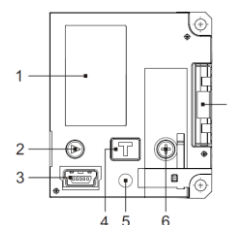

RCD add-on module DX³ 63A - 125A with metering/measuring unit

Cat.Nos: 4 106 57 to 4 106 59

5. GENERAL CHARACTERISTICS (continued)

Programming pages:

- The settings are implemented by pressing the key .
- The adjustable parameters are the values of the residual current and the tripping time:

Rated residual current (possible settings 30mA, 300mA, 1A, 3A):



Tripping time (possible settings 0s, 300ms, 1s, 3s):

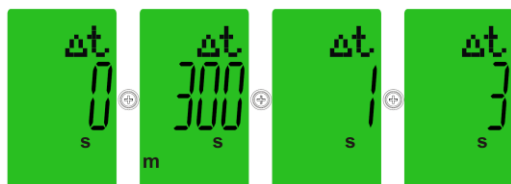

Display pages:

- The display of the pages is realised via the navigation button .
- (According to the version "metering unit" or "measuring unit" some pages are not available).

- Display of set parameters:

Rated residual current (set value)

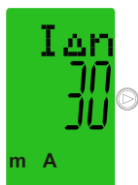

Tripping time (set value)



5. GENERAL CHARACTERISTICS (continued)

Display pages - Measured quantities:

- Display of measured quantities:

Current (phases / neutral / residual current)

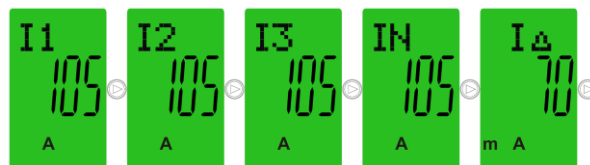

Phase Voltages



Power (active and reactive) and Power Factor



Frequency



Active energy (positive and negative)

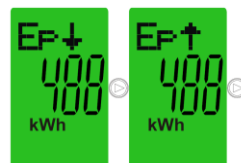

Reactive energy (positive and negative)



THD of the Phase Voltages

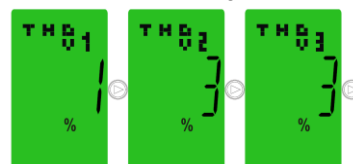

THD of Currents (phase and neutral)

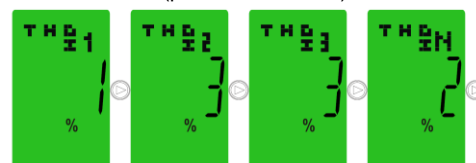

5. GENERAL CHARACTERISTICS *(continued)*

Display pages - Measured quantities *(continued)*:

- . Historical of causes of recent trips :
 - no tripping
 - trip due to residual current fault (value of the residual current)
 - trip by test key
 - overheating (temperature value)



- . Exhausted batteries (the symbol  appears on all pages):

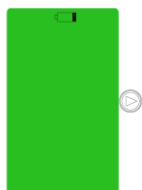

Integration of the add-on module in the remote display and monitoring system:

- . The communication port is located on the lower side of the device.

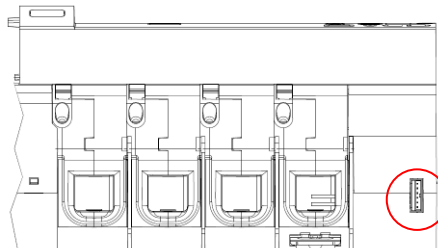

The port enables the integration of the device in the monitoring system via the RS485 communication interface (ref 4 210 75) and the Gateway RS485/IP.

Wiring diagram:

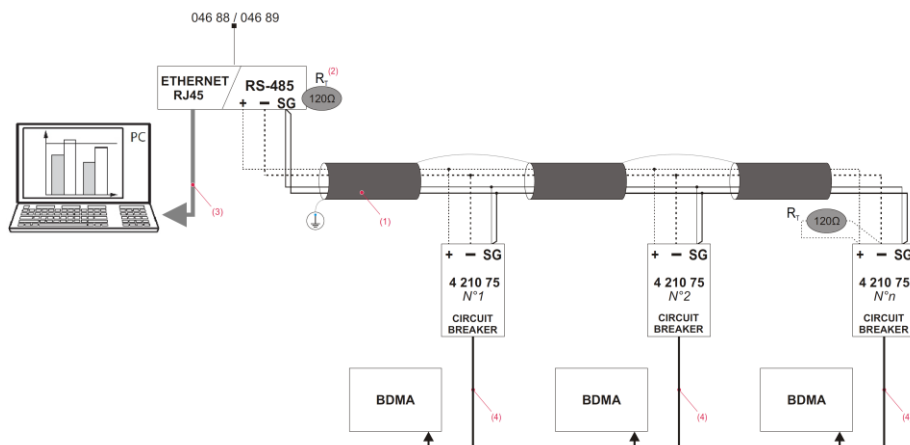

(1)RS485:

Prescribed use of Cable Belden 9842 (or equivalent) for a maximum bus length of 1000m or category 6 Cable (FTP or UTP) for a maximum length of 50m;

(2)Termination Resistor RT integrated.

(3)Ethernet:

Category 6 Cable (FTP or UTP).

(4)Cable supplied with the module 4 210 75.

RCD add-on module DX³ 63A - 125A with metering/measuring unit

Cat.Nos: 4 106 57 to 4 106 59

6. COMPLIANCE AND APPROVALS

In accordance with standards:

- . IEC/EN 61009-1.
- . IEC/EN 60947-2.
- . IEC 60051
- . IEC 61557-12.
- . IEC 62053
- . Compliance with Directives 2014/35/UE (LVC), subsequent modifications and additions.
- . Compliance with Directives 2014/30/UE (EMC), subsequent modifications and additions.

Environment respect – Compliance with CEE directives:

- . Compliance with Directive 2011/65/UE called "RoHS" provides the banishment of hazardous substances, subsequent modifications and additions.
- . Compliance with Directives 91/338/CEE of 18/06/91 and decree 94-647, subsequent modifications and additions.

Plastic materials :

- . Halogen-free plastic materials.
- . Marking of parts according to ISO 11469 and ISO 1043.

Packaging:

- . Design and manufacture of packaging in accordance with decree 98-638 and Directive 94/62/EC, subsequent modifications and additions.

Compliance with IEC 61557-12

PMD Characteristics		
Type of characteristic	Specification values	Other complementary characteristics
Power quality assessment function	-	-
Classification of PMD	DD	-
Temperature	K55	-
Humidity + Altitude	Conditions standards	-
Active power or active energy function performance class	1	-

RCD add-on module DX³ 63A - 125A with metering/measuring unit

Cat.Nos: 4 106 57 to 4 106 59

6. COMPLIANCE AND APPROVALS (continued)

Compliance with IEC 61557-12

Symbol for functions	Measurement range	Function performance class according to IEC 61557-12	Other complementary characteristics
	63 A 125 A		63 A 125 A
P	0,0125...75 kW 0,025...150 kW	1	I _b =20 A, I _{max} =75A I _b =40 A, I _{max} =150 A UN=400 V, f _N =50 Hz
Q_A, Q_V	0,0125...75 kvar 0,025...150 kvar	1	I _b =20 A, I _{max} =75 A I _b =40 A, I _{max} =150 A UN=400 V, f _N =50 Hz
S_A, S_V	-	-	-
E_a	0...9999 MWh	1	I _b =20 A, I _{max} =75 A I _b =40 A, I _{max} =150 A UN=400 V, f _N =50 Hz
E_{rA}, E_{rV}	0...9999 Mvarh	1	I _b =20A, I _{max} =75A I _b =40A, I _{max} =150A UN=400V, f _N =50Hz
E_{apA}, E_{apV}	-	-	-
f	45...65 Hz	0.1	-
I	1,25...75 A 2,5...150 A	1	I _b =20 A, I _{max} =75 A I _b =40 A, I _{max} =150 A UN=400 V, f _N =50 Hz
I_N, I_{Nc}	1,25...75 A 2,5...150 A	1	I _b =20 A, I _{max} =75 A I _b =40 A, I _{max} =150 A UN=400 V, f _N =50 Hz
U	88...550 V	0.5	-
P_{FA}, P_{FV}	-	1	I _b =20 A, I _{max} =75 A I _b =40 A, I _{max} =150 A UN=400 V, f _N =50 Hz
P_{st}, P_{It}	-	-	-
U_{dip}	-	-	-
U_{swt}	-	-	-
U_{tr}	-	-	-
U_{int}	-	-	-
U_{nba}	-	-	-
U_{nb}	-	-	-
U_h	-	-	-
THD_u	-	-	-
THD-R_u	88...550 V	0.5	-
I_h	-	-	-
THD_i	1,25...75 A 2,5...150 A	1	I _b =20 A, I _{max} =75 A I _b =40 A, I _{max} =150 A
THD-R_i	-	-	-
Msv	-	-	-

7. CURVES

Residual current operating characteristic

- . Average tripping time depending on the intensity of the fault current.
- . Sensitivities 30mA, 300mA, 1000mA and 3000mA instantaneous.

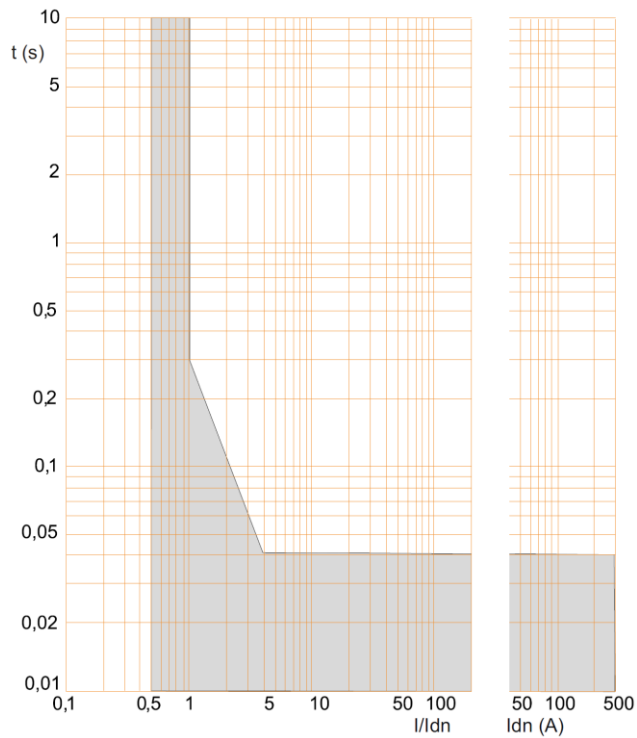

- . Sensitivities 300mA, 1000mA and 3000mA with a time delay of 300ms.

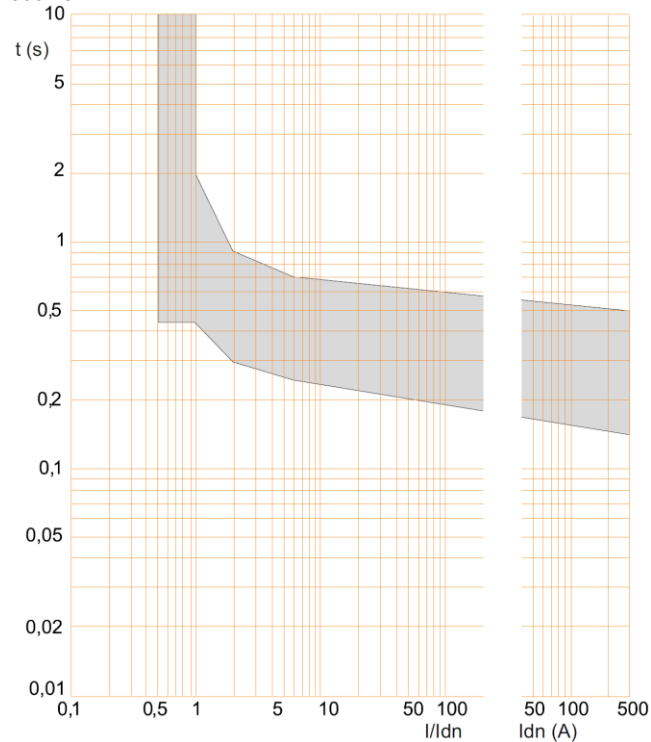

7. CURVES (continued)

- . Sensitivities 300mA, 1000mA and 3000mA with a time delay of 1s.

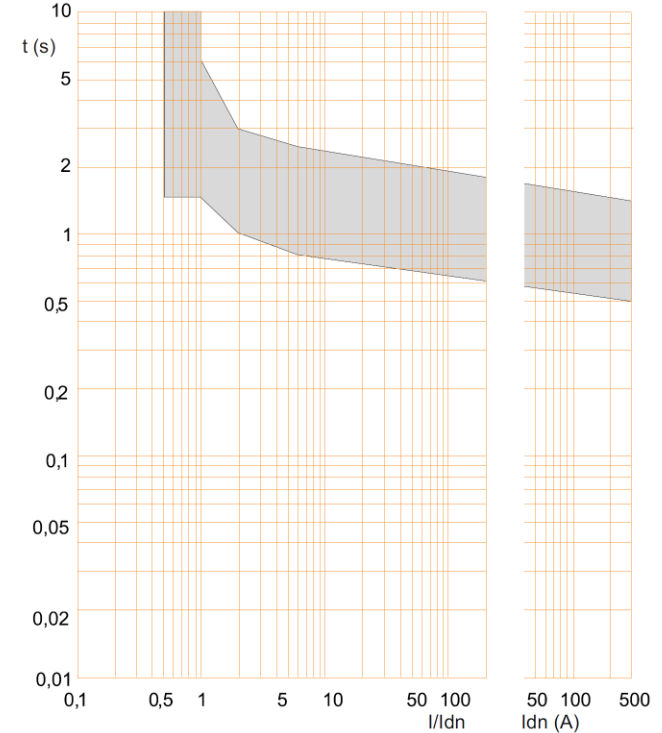

- . Sensitivities 300mA, 1000mA and 3000mA with a time delay of 3s.

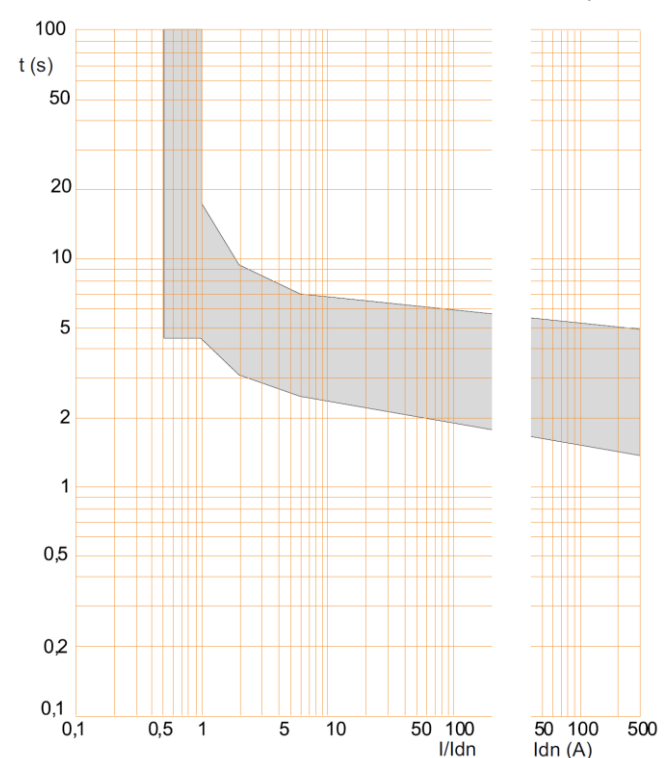

RCD add-on module DX³ 63A - 125A with metering/measuring unit

Cat.Nos: 4 106 57 to 4 106 59

8. AUXILIARIES AND ACCESSORIES

Installation software:

. XL Pro³.

Wiring accessories:

- . Terminal for Aluminium cable 95mm²(406311).
- . Terminal for Aluminium cable 50mm²(406310).

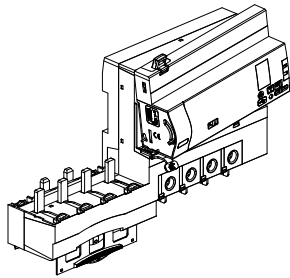

Bloc différentiel adaptable avec unité de comptage/mesure pour disjoncteurs DX³ 4 pôles hauts pouvoirs de coupure

RCD Add-on block with metering/measuring unit for high breaking capacity 4 poles DX³ circuit-breakers

Bloque diferencial con unidad de conteo/medida por interruptores 4 polos DX³ alto poder de corte

Compatibilité avec disjoncteurs DX³ / Compatibility with DX³ breakers / Compatibilidad con interruptores DX³

		Courbe / Curve / Curva	4 106 57	4 106 58	4 106 59
DX ³	10000A / 16kA	B, C, D	–	80A ≤ In ≤ 125A	80A ≤ In ≤ 125A
	25kA	B, C, Z	32A ≤ In ≤ 63A	32A ≤ In ≤ 125A	32A ≤ In ≤ 125A
	25kA	D, MA	12,5A ≤ In ≤ 63A	12,5A ≤ In ≤ 125A	12,5A ≤ In ≤ 125A
	36kA	C	10A ≤ In ≤ 63A	10A ≤ In ≤ 80A	10A ≤ In ≤ 80A
	50kA	B, C, D, MA	10A ≤ In ≤ 63A	10A ≤ In ≤ 63A	10A ≤ In ≤ 63A

Instructions d'assemblage / Assembly instructions / Instrucciones de montaje

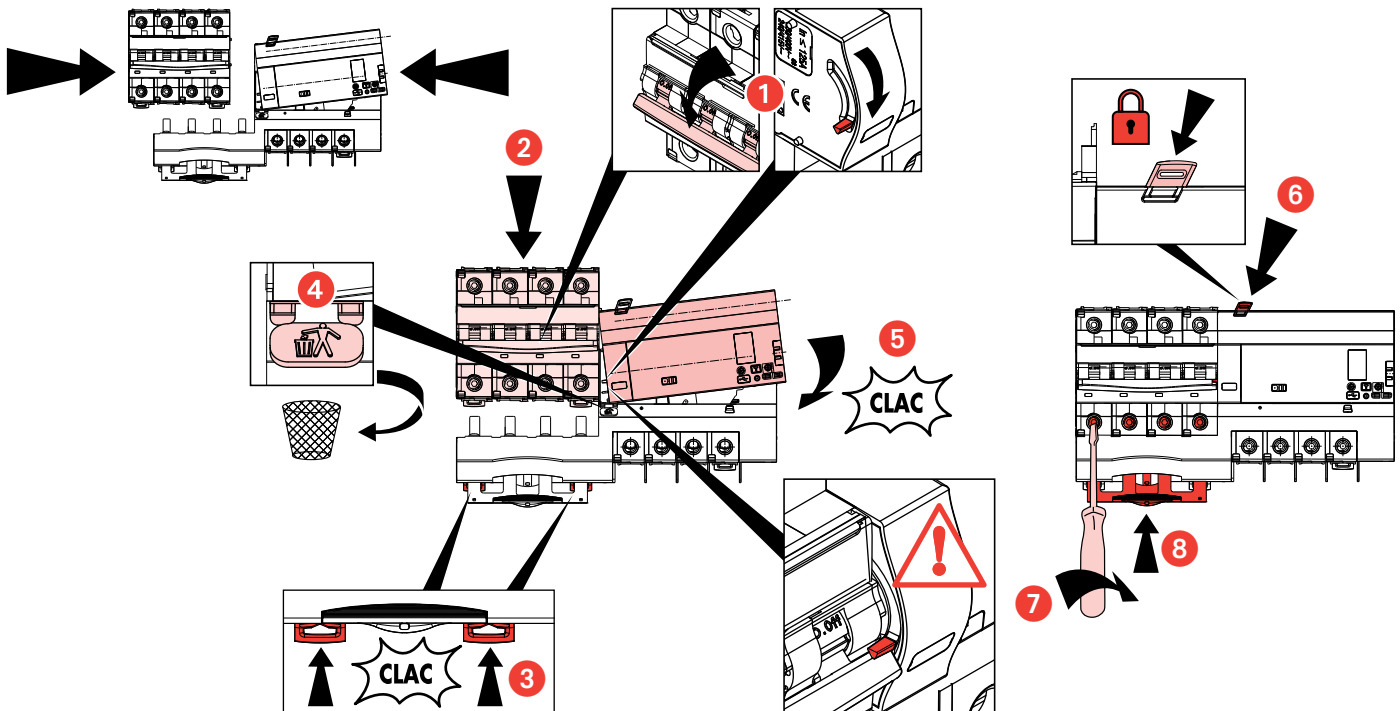

Instructions de câblage / Wiring instructions / Instrucciones de cableado

Diagram	Wiring Diagram	≤63A		≤125A		Diagram	63A & 125A	
		1.5 - 35mm ²	1.5 - 35mm ²	10 - 50mm ²	10 - 50mm ²		0.75 - 2.5mm ²	0.75 - 1.5mm ²
		6.5mm – PZ2 3Nm	4mm 5.5Nm				2.5mm	

LE06006AA

**Description des indicateurs et boutons de commande / Indicators and command buttons description /
 Descripción de los indicadores y los pulsadores**

1. Bouton de réglage / Setting button / Pulsador de reglaje
2. Led de signalisation / Indication led / Led de señalización
3. Port USB (seulement pour la mise à jour du firmware) / USB port (only for firmware update) / Puerto USB (sólo para la actualización del firmware)
4. Bouton de navigation / Navigation button / Pulsador de navegación
5. Sélecteur pour Test diélectrique / Selector for dielectrical test / Selector por prueba dieléctrica
6. Indicateur de déclenchement différentiel / Residual current tripping signal / Indicador de disparo diferencial
7. Ecran / Display / Pantalla
8. Bouton Test différentiel / Residual current test button / Botón de test diferencial
9. Emplacement batteries / Battery compartment / Compartimento de la batería
10. Port de communication / Communication port / Puerto de comunicación

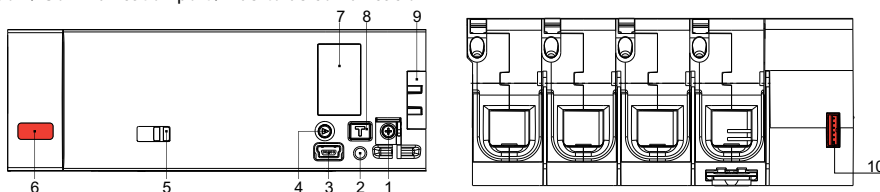

**Conformité IEC 61557-12 Edition 1 (08/2007) / Conformity IEC 61557-12 Edition 1 (08/2007) /
 Conformidad con IEC 61557-12 Edition 1 (08/2007)**

Caractéristiques du dispositif de mesure et de surveillance des performances (PMD) / Performance measuring and monitoring device (PMD) characteristics / Características del dispositivo por la medida y el control de las prestaciones (PMD)

Type de caractéristique / Type of characteristic / Tipo de característica	Valeurs caractéristiques possibles / Specification values / Valores característicos posibles	Autres caractéristiques complémentaires / Other complementary characteristics / Otras características complementarias
Fonction d'évaluation de la qualité de l'alimentation / Power quality assessment function / Funcion de evaluacion de la calidad de la alimentacion	-	-
Classification des PMD / Classification of PMD /Clasificacion de los PMD	DD	-
Température / Temperature / Temperatura	K55	-
Humidité + Altitude / Humidity + Altitude / Humedad + Altitud	Standard conditions	-
Classe de performance de fonctionnement de la puissance active ou de l'énergie active / Active power or active energy function performance class / Clase de rendimiento de funcionamiento de la potencia activa o de la energia activa	1	-

Caractéristiques des fonctions / Characteristics of functions / Características de las funciones

Symbole des fonctions / Function symbols / Símbolo de las funciones	Plage de mesure / Measurement range / Rango de medición	Classe de performance de fonctionnement, conformément à la IEC 61557-12 / Function performance class according to IEC 61557-12 / Clase de rendimiento de funcionamiento, según la norma IEC 61557-12	Autres caractéristiques complémentaires / Other complementary characteristics / Otras características complementarias
	63 A 125 A		63 A 125 A
P	0,0125...75 kW 0,025...150 kW	1	I _b =20 A, I _{max} =75 A, I _b =40 A, I _{max} =150 A UN=400 V, f _N =50 Hz
Q _A , Q _V	0,0125...75 kvar 0,025...150 kvar	1	I _b =20 A, I _{max} =75 A, I _b =40 A, I _{max} =150 A UN=400 V, f _N =50 Hz
S _A , S _V	-	-	-
E _a	0...9999 MWh	1	I _b =20 A, I _{max} =75 A, I _b =40 A, I _{max} =150 A UN=400 V, f _N =50 Hz
E _{rA} , E _{rV}	0...9999 Mvarh	1	I _b =20A, I _{max} =75 A, I _b =40 A, I _{max} =150A UN=400 V, f _N =50 Hz
E _{apA} , E _{apV}	-	-	-
f	45...65 Hz	0.1	-
I	1,25...75 A 2,5...150 A	1	I _b =20 A, I _{max} =75 A, I _b =40 A, I _{max} =150 A UN=400 V, f _N =50 Hz
I _N , I _{Nc}	1,25...75 A 2,5...150 A	1	I _b =20 A, I _{max} =75 A, I _b =40 A, I _{max} =150 A UN=400 V, f _N =50 Hz
U	88...550 V	0.5	-
P _{FA} , P _{FV}	-	1	I _b =20 A, I _{max} =75 A, I _b =40 A, I _{max} =150 A UN=400 V, f _N =50 Hz
P _{st} , P _{It}	-	-	-
U _{dip}	-	-	-
U _{swl}	-	-	-
U _{tr}	-	-	-
U _{int}	-	-	-
U _{nba}	-	-	-
U _{nb}	-	-	-
U _h	-	-	-
THD _u	-	-	-
THD-R _u	88...550 V	0.5	-
I _h	-	-	-
THD _i	1,25...75 A 2,5...150 A	1	I _b =20 A, I _{max} =75 A, I _b =40 A, I _{max} =150 A
THD-R _i	-	-	-
Msv	-	-	-

Programmation / Programming / Programación

Réglages par défaut

Δn (A) = 0,03

Factory settings

Δt (s) = 0

Configuraciones de fabrica



Le réglage Δn (A) = 0,03 est lié à la sécurité des personnes. Il faut absolument plomber le capot afin de prévenir le risque de modification accidentelle ou délibérée des valeurs de réglage.

The adjustment Δn (A) = 0.03 is linked to the safety of persons. It is absolutely necessary to seal the cover to avoid the risk of accidental or deliberate modification of adjusted values.

El ajuste Δn (A) = 0,03 está vinculado a la seguridad de las personas. Es absolutamente necesario sellar la tapa para evitar el riesgo de modificación deliberada o accidental de los valores ajustados.

• Modification des réglages / Setting modification / Modificación de los configuraciones

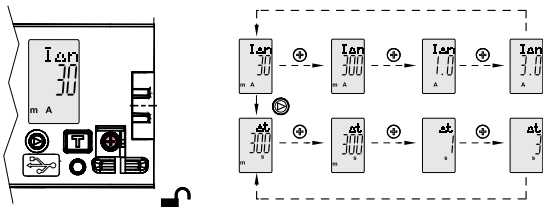

• Réglages possibles / Available settings / Configuraciones posibles:

		Δn (A)			
		0,03	0,3	1	3
Δt (s)	0	✓	✓	✓	✓
	0,3	X	✓	✓	✓
	1	X	✓	✓	✓
	3	X	✓	✓	✓



Avec un seuil différentiel de 30 mA (Δn (A) = 0,03), le temps de déclenchement est réglé automatiquement à Δt (s) = 0

With differential threshold of 30 mA (Δn (A) = 0,03), the trip time automatically sets to Δt (s) = 0

Con un umbral de disparo diferencial de 30 mA (Δn (A) = 0,03), el tiempo de desconexión está ajustado automáticamente a Δt (s) = 0

Consultation / Consultation / Consultación

• Affichage des valeurs réglées / Display of setting values / Visualización de los valores de ajuste

Allumage de l'écran à la première impulsion sur . L'affichage des valeurs Δn et Δt paramétrées alterne à une fréquence de 3 secondes

The display ignites at the first press on . The viewing of set values of Δn and Δt takes place alternately with a viewing frequency of 3 s.

La pantalla se enciende al primer impulso sobre . La visualización de los valores de ajuste de Δn y Δt se sucede alternativamente con una frecuencia de 3 segundos.

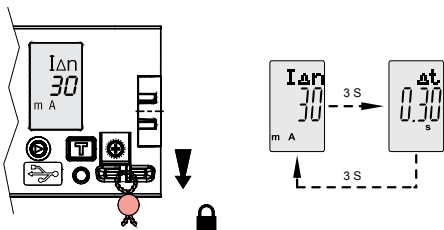

Auto-extinction du rétro-éclairage de l'écran après 180 secondes.

Automatically turn off of the backlight of the screen after 180 seconds

Apagamiento automático de la retroiluminación de la pantalla después de 180 segundos



En cas de batterie faible, le symbole indiqué à droite apparaît sur toutes les pages d'affichage.

In case of low battery, the symbol shown on the right appears on all pages.

En caso de nivel bajo de batería el símbolo aparece en todas las páginas.



• Affichage des valeurs de mesure / Display of measured values / Visualización de los valores medidos

Navigation par impulsions successives sur le bouton . / Navigation by successive pulses on . / Navegación per impulsos sucesivos sobre .

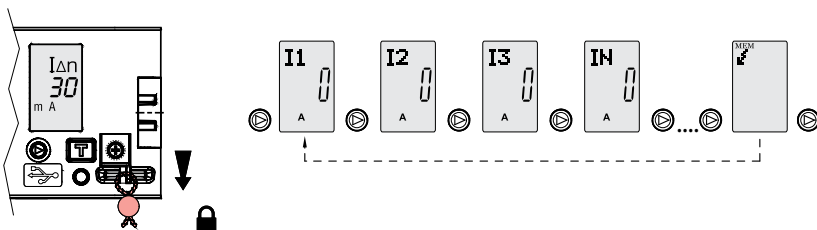

· voir tableau à la page suivante
· see table on next page
· ver tabla a la página siguiente





FONCTIONS DE MESURE / MEASURE FUNCTIONS / FUNCIONES DE MEDIDA							
			4 106 57 / 58		4 106 59		
				Local Display	COM	Local Display	COM
I1	(A)		Valeur instantanée de IL1 / IL1 instantaneous value / Valor instantáneo de IL1	✓	✓	✓	✓
I2	(A)		Valeur instantanée de IL2 / IL2 instantaneous value / Valor instantáneo de IL2	✓	✓	✓	✓
I3	(A)		Valeur instantanée de IL3 / IL3 instantaneous value / Valor instantáneo de IL3	✓	✓	✓	✓
IN	(A)		Valeur instantanée de IN / IN instantaneous value / Valor instantáneo de IN	✓	✓	✓	✓
IΔ	(A)		Valeur instantanée de courant différentiel / Instantaneous value of residual current / Valor instantáneo de corriente residual	✓	✓	✓	✓
V1N	(V)		Tension simple / Phase Voltage / Tensione de fase	-	-	✓	✓
V2N	(V)		Tension simple / Phase Voltage / Tensione de fase	-	-	✓	✓
V3N	(V)		Tension simple / Phase Voltage / Tensione de fase	-	-	✓	✓
Freq.	(Hz)		Fréquence / Frequency / Frecuencia	-	-	✓	✓
Ptot	(W)		Puissance active instantanée / Instantaneous active power / Potencia activa instantánea	✓	✓	✓	✓
Qtot	(var)		Puissance réactive instantanée / Instantaneous reactive power / Potencia reactiva instantánea	-	-	✓	✓
PF			Facteur de puissance / Power factor / Factor de potencia	-	-	✓	✓
Ep ↓	(kWh)		Energie active consommée / Active energy consumed / Energia activa consumida	✓	✓	✓	✓
Ep ↑	(kWh)		Energie active restituée / Active energy returned / Energia activa devuelta	✓	✓	✓	✓
Eq ↓	(kvarh)		Energie réactive consommée / Reactive energy consumed / Energia reactiva consumida	-	-	✓	✓
Eq ↑	(kvarh)		Energie réactive restituée / Reactive energy returned / Energia reactiva devuelta	-	-	✓	✓
THD V1	(%)		THD tensions simples / Voltage THD / THD tensiones	-	-	✓	✓
THD V2	(%)		THD tensions simples / Voltage THD / THD tensiones	-	-	✓	✓
THD V3	(%)		THD tensions simples / Voltage THD / THD tensiones	-	-	✓	✓
THD I1	(%)		THD courant / Current THD / THD corriente	-	-	✓	✓
THD I2	(%)		THD courant / Current THD / THD corriente	-	-	✓	✓
THD I3	(%)		THD courant / Current THD / THD corriente	-	-	✓	✓
THD IN	(%)		THD courant de neutre/ Neutral current THD / THD corriente de neutro	-	-	✓	✓
MEM IΔn	(mA)		Valeur dernier déclenchement sur défaut différentiel / Last tripping value due to earth leakage / Valor ultimo disparo por derivación a tierra	✓	✓	✓	✓
MEM T	(°C)		Valeur dernier déclenchement par température excessive / Last tripping value due to overtemperature / Valor ultimo disparo por sobretemperatura	✓	✓	✓	✓
MEM Tst			Dernier déclenchement par bouton test / Last tripping due to test button / Valor ultimo disparo par boton test	✓	✓	✓	✓
MEM			Aucun déclenchement / No tripping / Sin disparo	✓	✓	✓	✓

Schéma explicatif énergie consommée ou restituée / Explanatory scheme consumed or returned energy / Esquema explicativo energía consumida o devuelta.



SIGNALISATION LED BI-COULEUR / DOUBLE COLOR LED INDICATIONS / SEÑALIZACIÓN LED BICOLOR

Couleur / Color / Color	Etat / State / Estado	Evènement / Event / Evento	Priorité / Priorité / Prioridad
Verte / Green / Verde	Allumé / Turned on / Encendida	$0 \leq \Delta n < 45\%$ du seuil défini $0 \leq \Delta n < 45\%$ settled tripping threshold $0 \leq \Delta n < 45\%$ del valor de tropezar	3
Verte / Green / Verde	Clignotante / Blinking / Intermitente	Réglage en cours (5s) / problème interne Setting in progress (5s) / internal problem Siendo reglaje (5s) / problema interno	3
Rouge / Red / Rojo	Allumé / Turned on / Encendida	$45\% \leq \Delta n < 60\%$ du seuil défini $45\% \leq \Delta n < 60\%$ settled tripping threshold $45\% \leq \Delta n < 60\%$ del valor de tropezar	3
Rouge / Red / Rojo	Clignotante / Blinking / Intermitente	$\Delta n \geq 60\%$ du seuil défini $\Delta n \geq 60\%$ settled tripping threshold $\Delta n \geq 60\%$ del valor de tropezar	3
Rouge - Verte / Red - Green / Rojo - Verde	Clignotement alterné / Alternate blinking / Intermitente alternando	Auto-protection contre la surchauffe Self-protection due to overheating Autoprotección por sobretemperatura	1

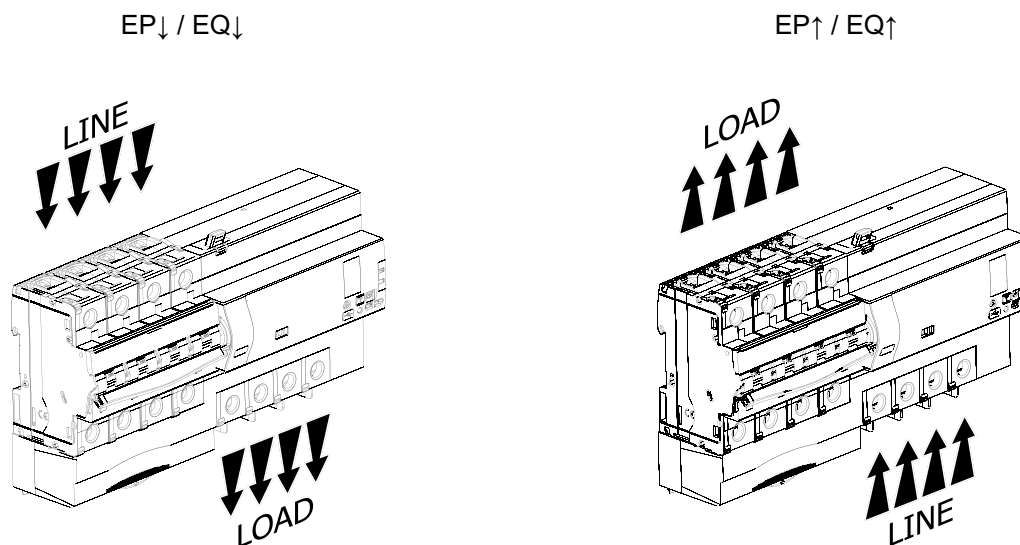
En cas de plusieurs évènements simultanés, celui dont la priorité la plus élevée est signalé. Le niveau 1 est le plus élevé.

In case of several events at the same time, the signal is the one with the highest priority. The highest priority is 1.

En caso de varios acontecimientos simultáneos, cuya prioridad el más elevado es señalada. El nivel 1 es el más elevado.

Intégration du BDMA dans le système d'affichage à distance et système de supervision / Integration of BDMA in the remote display and monitoring system / Integración de BDMA en el sistema de visualización remota y de monitorización

La porte de communication est située dans la partie basse du bloc différentiel / The communication port is located on the lower side of the device / El puerto de comunicación se encuentra en la parte inferior del bloque diferencial



Schéma de raccordement / Wiring diagram / Esquema de conexión



(1)RS485:

Utilisation prévue du Câble Belden 9842 (ou équivalent) pour une longueur maximale du bus de 1000m ou du Câble Catégorie 6 (FTP ou UTP) pour une longueur maximale de 50m;

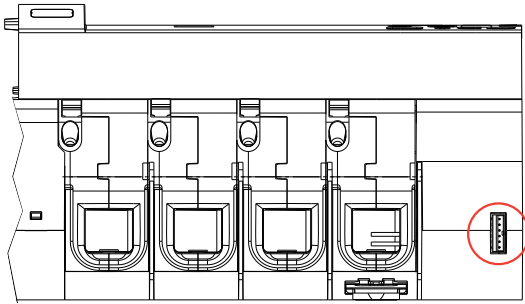
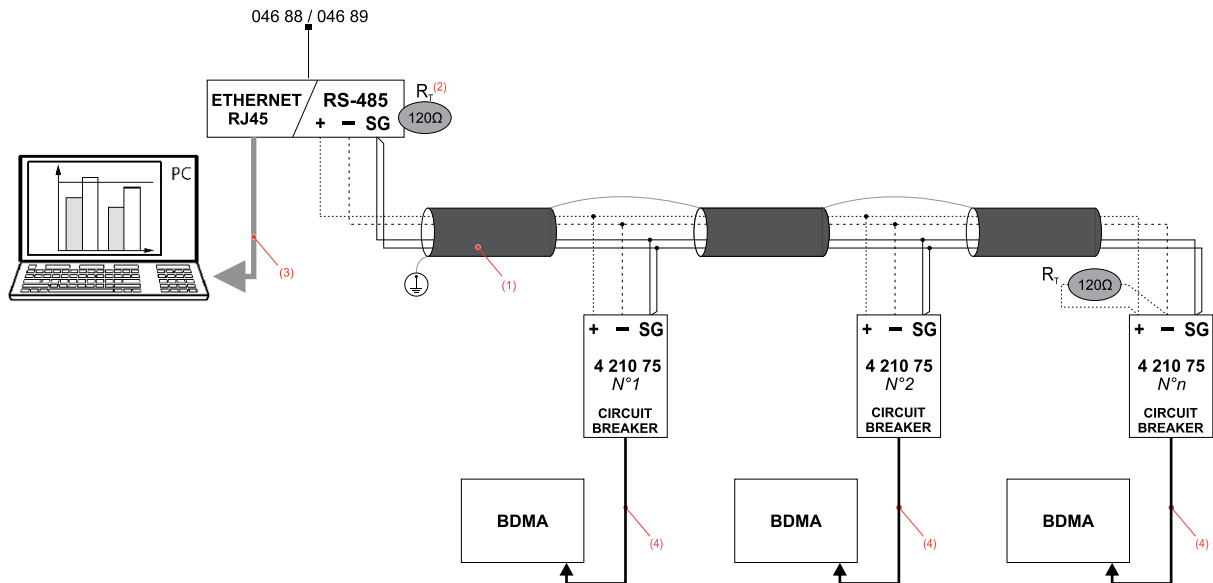
Prescribed use of Cable Belden 9842 (or equivalent) for a maximum bus length of 1000m or Category 6 cable (FTP or UTP) for a maximum length of 50m;

Utilización correcta de Cable Belden 9842 (o equivalente) para una longitud máxima del bus de 1000m o cable de Categoría 6 (FTP o UTP) para una longitud máxima de 50 m.

(2)Résistance de terminaison RT intégrée / Termination resistor RT integrated / Resistencia terminal RT integrada

(3)Ethernet:

Câble Catégorie 6 (FTP ou UTP) / Category 6 cable (FTP or UTP) / Cable de categoria 6 (FTP o UTP).

(4)Cordon livrée avec le module 4 210 75 / Cable supplied with the module 4 210 75 / Cable suministrado con el módulo 4 210 75.

Maintenance / Maintenance / Mantenimiento

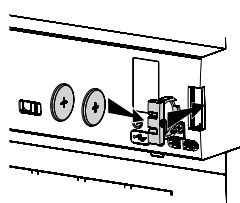
BATTERIES / BATTERIES / PILAS (2x CR1616; 3V)			
En cas d'absence de la batterie ou si la batterie est hors service, l'écran s'allume si l'appareil est sous tension	If the battery is not present or is out of service, the display turns on only when the device is supplied	Si la batería no está presente o está fuera de servicio, la pantalla se enciende solamente cuando el dispositivo está alimentado	
En fonctionnement sur batterie, l'écran s'éteint après 10s s'il n'est pas utilisé.	If battery powered, the display switch off after 10s if not used.	Si se alimenta con batería, la pantalla se apaga tras 10s sin utilizarla.	
Insertion / Remplacement des batteries	Inserting / Replacing the batteries	Colocación / Cambio de las pilas	
A la fin de leur cycle de vie, recycler les batteries conformément à la directive européenne 2006/66/CE traitant des batteries, accumulateurs et déchets associés.	At the end of life cycle, recycle the batteries according the EU directive 2006/66/CE about the batteries, accumulators and relative wastes.	Cuando se agoten las baterías, reciclarlas conforme a la directiva europea 2006/66/CE relativa a baterías, acumuladores y residuos asociados	