

# RCCBs - DX<sup>3</sup>-ID

residual current circuit breakers 16 A to 100 A - AC, A, Hpi and B types



4 115 25



4 117 05



4 117 60

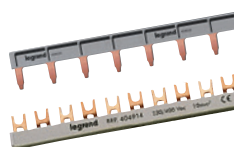

Technical characteristics [see e-catalogue](#)

Conform to IEC 61008 - 1

- Compatible with prong-type and fork type supply busbars
- AC type : detect sinusoidal AC residual currents
- A type : detect sinusoidal AC and pulsating DC residual currents
- Hpi type (High immunity) : detect AC and pulsating DC residual currents  
Enhanced immunity to unwanted tripping in disturbed environments
- B type : detect sinusoidal AC, pulsating DC and smooth DC residual currents

Can be equipped with DX<sup>3</sup> signalling and remote tripping auxiliaries and motorised controls (p. 64)

Pack	Cat.Nos	2-pole 230 V $\sim$		
		<b>AC type</b>		
		Sensitivity (mA)	Nominal Rating In (A)	Number of modules
1	4 115 00	10	16	2
1	4 115 04	30	25	2
1	4 115 05	30	40	2
1	4 115 06	30	63	2
1	4 115 07	30	80	2
1	4 115 08	30	100	2
1	4 115 14	100	25	2
1	4 115 15	100	40	2
1	4 115 16	100	63	2
1	4 115 17	100	80	2
1	4 115 24	300	25	2
1	4 115 25	300	40	2
1	4 115 26	300	63	2
1	4 115 27	300	80	2
1	4 115 28	300	100	2
1	4 115 37	100 selective	100	2
1	4 115 43	300 selective	63	2
		<b>A type</b>		
1	4 115 50	10	16	2
1	4 115 54	30	25	2
1	4 115 55	30	40	2
1	4 115 56	30	63	2
1	4 115 57	30	80	2
1	4 115 69	300	25	2
1	4 115 70	300	40	2
1	4 115 71	300	63	2
1	4 115 72	300	80	2
		<b>Hpi type</b>		
1	4 115 90	30	25	2
1	4 115 91	30	40	2
1	4 115 92	30	63	2
		<b>B type</b>		
		Can be equipped with dedicated auxiliary contact Cat. No 4 062 59 (p. 64)		
1	4 118 42	30	40	4
1	4 118 43	30	63	4
1	4 118 44	300	40	4
1	4 118 45	300	63	4

Pack	Cat.Nos	4-pole - 400 V $\sim$ - neutral on right-hand side			
		<b>AC type</b>			
		Vis/vis	Sensitivity (mA)	In (A)	Number of modules
1	4 117 02		30	25	4
1	4 117 03		30	40	4
1	4 117 04		30	63	4
1	4 117 05		30	80	4
1	4 117 12		100	25	4
1	4 117 13		100	40	4
1	4 117 14		100	63	4
1	4 117 15		100	80	4
1	4 117 22		300	25	4
1	4 117 23		300	40	4
1	4 117 24		300	63	4
1	4 117 25		300	80	4
1	4 117 45		300 selective	40	4
1	4 117 46		300 selective	63	4
1	4 117 32		500	25	4
1	4 117 33		500	40	4
1	4 117 34		500	63	4
1	4 117 35		500	80	4
		<b>A type</b>			
1	4 117 59		30	25	4
1	4 117 60		30	40	4
1	4 117 61		30	63	4
1	4 117 62		30	80	4
1	4 117 63		30	100	4
1	4 117 69		100	25	4
1	4 117 70		100	40	4
1	4 117 71		100	63	4
1	4 117 72		100	80	4
1	4 117 73		100	100	4
1	4 117 79		300	25	4
1	4 117 80		300	40	4
1	4 117 81		300	63	4
1	4 117 82		300	80	4
1	4 117 83		300	100	4
1	4 118 00		300 selective	40	4
1	4 118 01		300 selective	63	4
1	4 117 89		500	25	4
1	4 117 90		500	40	4
1	4 117 91		500	63	4
1	4 117 92		500	80	4
1	4 117 93		500	100	4
		<b>B type</b>			
		Can be equipped with dedicated auxiliary contact Cat. No 4 062 59 (p. 64)			
1	4 118 46		30	40	4
1	4 118 47		30	63	4
1	4 118 48		300	40	4
1	4 118 49		300	63	4

Pack	Cat.Nos	4-pole - 400 V $\sim$ - neutral on left-hand side			
		<b>B type</b>			
		Can be equipped with dedicated auxiliary contact Cat. No 4 062 59 (p. 64)			
1	4 118 46		30	40	4
1	4 118 47		30	63	4
1	4 118 48		300	40	4
1	4 118 49		300	63	4

Auxiliaries, accessories and remote control **p. 64**



## DX<sup>3</sup> RCDS

### Technical data for DX<sup>3</sup> RCDS

	RCCB		
	Type AC	Type A-S	Type Hpi
<b>Specification</b>	IS 12640 (part 1) 2008 IEC 61008 - 1	IEC 61008 - 1 EN 61008 - 1	EN 61008 - 1 IEC 61008 - 1
<b>No. of modules</b>	- Double pole - Four pole	2 4	2 4
<b>Electrical characteristics</b>			
<b>Nominal rating In (A)</b>	- Double pole - Four pole	25, 40, 63, 80, 100 25, 40, 63, 80, 100	63, 80 25, 40, 63, 80
<b>Rated sensitivity (mA)</b>	- Double pole - Four pole	30, 100, 300 30, 100, 300	300 300
<b>Rated frequency (Hz)</b>		50 / 60	50 / 60
<b>Rated operating voltage Ue (V AC)</b>	- Double pole - Four pole	230 230 / 415	230 400
<b>Minimum operating voltage (V AC)</b>		12	12
<b>Minimum operating voltage for test button (V AC)<sup>(1)</sup></b>	- Double pole - Four pole	170 196	170 196
<b>Rated insulation voltage Ui (V AC)</b>	- Double pole - Four pole	250 500	250 500
<b>Rated impulse withstand voltage Uimp (kV)</b>		6	6
<b>Breaking capacity</b>	As per IS 12640 (part 1) 2008, IEC 61008 - 1		
<b>Rated making &amp; breaking capacity (Im)</b>	- Up to 40 A - From 63 A and above	500 A 10 x In	- 630 A
<b>Rated residual making &amp; breaking capacity (IΔm)</b>	- Up to 40 A - From 63 A and above	1000 A 1000 A	- 1000 A
<b>Rated conditional short circuit current (Inc)</b>		10000 A	10000 A
<b>Rated conditional residual short circuit current (IΔc)</b>		10000 A	10000 A
<b>Rated service short circuit capacity (Ics)</b>		-	-
<b>Rated short circuit capacity (Icn)</b>		-	-
<b>Operating temperature (°C)</b>		- 25 to 70	- 25 to 70
<b>Endurance (0.C cycle)</b>	- Mechanical - On load at in X cos φ 0.9 - Via test button - By fault current (sensitivity)	20,000 10,000 2,000 2,000	20,000 10,000 2,000 2,000
<b>Testing</b>	By pressing test button grey dolly will come to OFF position It is recommended to test RCCB once a month	By pressing test button grey dolly will come to OFF position It is recommended to test RCCB once a month	By pressing test button, grey dolly will come to OFF position It is recommended to test RCCB once a month
<b>Fault indication</b>	- Earth leakage  - Overload and shortcut	Grey dolly will come to OFF position  -	Grey dolly will come to OFF position  -
<b>Resetting</b>		Switch on grey dolly	Switch on grey dolly
<b>Terminals</b>	- Rigid - Flexible	1 - 35 sq. mm 1 - 25 sq. mm	1 - 35 sq. mm 1 - 25 sq. mm
<b>Type of protection</b>			
Earth leakage		•	•
Overload		-	-
Short circuit		-	-
<b>Add on electrical accessories*</b>			
Auxiliary		•	•
Fault signaling		•	•
Shunt trip		•	•
Under voltage		•	•
Over voltage		•	•

\* - Accessories are mounted on the left hand side of the product.  
At a time a maximum of three accessories can be mounted.  
(1) - Between phase and neutral

RCBO				
Type AC	Type AC - 2 & 4 modules	Type Hpi	Type A	
IS 12640 (part 2) 2008 IEC 61009 - 1	NFC 61 - 410 EN 61009 - 1 IEC 61009 - 1	EN 61009 - 1 IEC 61009 - 1	EN 61009 - 1 IEC 61009 - 1	
4	2	2	-	
7	4	-	4	
6, 10, 16, 25, 32, 40, 63	6, 10, 16, 20, 25, 32	25, 32, 40	25, 32, 40	
16, 25, 32, 40, 63	10, 16, 20, 25, 32	-	-	
30, 100, 300	30, 300	30	30, 300	
30, 100, 300	-	-	-	
50	50	50 / 60	50 / 60	
230	230	230	-	
415	415	-	415	
12	12	12	12	
170	170	170	-	
196	196	-	196	
500	250	250	-	
500	500	-	500	
4	6	6	6	
<b>As per IS 12640 (part 2) 2008, IEC 61009 - 1</b>				
10000 A	6000 A	6000 A	6000 A	
10000 A	-	-	-	
10000 A	3000 A	3000 A	3000 A	
10000 A	-	-	-	
-	-	-	-	
-	-	-	-	
7500 A	6000 A	6000 A	6000 A	
10000 A	6000 A	6000 A	6000 A	
- 25 to 70	- 25 to 70	- 25 to 70	- 25 to 70	
20,000	20,000	20,000	20,000	
10,000	10,000	10,000	10,000	
1,000	1,000	1,000	1,000	
1,000	1,000	1,000	1,000	
By pressing test button, black dolly will come to OFF position It is recommended to test RCBO once a month	By pressing test button, black dolly will come to OFF position It is recommended to test RCBO once a month	By pressing test button, black dolly will come to OFF position It is recommended to test RCBO once a month	By pressing test button, black dolly will come to OFF position It is recommended to test RCBO once a month	
Black & blue dolly will come to OFF position	Black dolly will come to OFF position & blue indicator will appear on front face window	Black dolly will come to OFF position & blue indicator will appear on front face window	Black dolly will come to OFF position & blue indicator will appear on front face window	
Black dolly will come to OFF position	Black dolly will come to OFF position	Black dolly will come to OFF position	Black dolly will come to OFF position	
Switch on black dolly	Switch on black dolly	Switch on black dolly	Switch on black dolly	
1 - 35 sq. mm	0.75 - 16 sq. mm	0.75 - 16 sq. mm	0.75 - 16 sq. mm	
1 - 25 sq. mm	0.75 - 10 sq. mm	0.75 - 10 sq. mm	0.75 - 10 sq. mm	
•	•	•	•	
•	•	•	•	
•	•	•	•	
•	•	•	•	
•	•	•	•	
•	•	•	•	
•	•	•	•	
•	•	•	•	

## Isolating switches DX<sup>3</sup>-IS

### technical characteristics

#### DX<sup>3</sup>-IS remote trip head isolating switches

##### Electrical characteristics

Thermal rating (Ith)	40 - 63 A 1 module/pole	100 - 125 A 1.5 module/pole
Terminals	Cage	Cage
Connection	flexible	1.5 to 25 mm <sup>2</sup>
	rigid	1.5 to 35 mm <sup>2</sup>
Insulation voltage (Ui)	500 V ~	500 V ~
Impulse withstand voltage (Uimp)	6 kV	6 kV
Category of use <sup>(1)</sup>	AC 22A / AC 23A	100 A = AC 22A / AC 23A 125 A = AC 22A
Short time withstand current (Icw)	1000 A during 1 s 1700 A during 0.5 s	1000 A during 1 s 1500 A during 0.5 s
Short-circuit making capacity (Icm)	3000 A	1500 A
No. of electrical operations	15000	10000
Protection index	IP 2X wired	IP 2X wired

(1) test conditions according to IEC 60947-3  
AC 22 A: combined motor/resistor breaking with frequent operations  
AC 23 A: inductive motor breaking at In/2 with frequent operations

#### DX<sup>3</sup>-IS isolating switches

##### Electrical characteristics

Thermal rating (Ith)	16 - 40 A 0.5 module/pole	40 - 63 A 1 module/pole	100 - 125 A 1 module/pole
Terminals	Cage	Cage	Cage
Connection	flexible	1.5 to 10 mm <sup>2</sup>	4 to 35 mm <sup>2</sup>
	rigid	1.5 to 16 mm <sup>2</sup>	4 to 50 mm <sup>2</sup>
Insulation voltage (Ui)	500 V ~	500 V ~	500 V ~
Impulse withstand voltage (Uimp)	6 kV	6 kV	6 kV
Category of use <sup>(1)</sup>	AC 22 A	AC 22 A	AC 22 A
Short time withstand current (Icw)	750 A	2000 A	2500 A
Short-circuit making capacity (Icm)	1500 A	3000 A	3700 A
No. of electrical operations	30000	20000	5000
Protection index	IP 2X wired	IP 2X wired	IP 2X wired

(1) test conditions according to IEC 60947-3  
AC 22 A: combined motor/resistor breaking with frequent operations

## RCCBs DX<sup>3</sup>-ID

### technical characteristics

#### DX<sup>3</sup>-ID - RCCBs (residual current circuit breakers)

##### Connection cross-section

RCCBs	Cable (mm <sup>2</sup> )	
	Rigid	Flexible
Connection at top and bottom	50	35

#### AC type - Standard applications

AC type RCCBs detect sinusoidal AC residual currents. In the majority of cases (standard applications), they are used for AC current detection at 50 Hz.

#### A type - Specific applications: dedicated lines

In addition to the characteristics of AC type RCCBs, A type RCCBs also detect pulsating DC residual currents. They are used whenever fault currents are not sinusoidal. They are particularly suitable for the following specific applications: hobs, washing machines or materials that may produce DC fault currents, speed drives with frequency inverters, etc.

#### B type - Specific applications: dedicated lines

In addition to the characteristics of A type RCCBs, B type RCCBs also detect smooth DC residual currents. They are used whenever fault currents are not sinusoidal. They are particularly suitable for the following specific applications: speed drives and inverters for supplying motors for pumps, lifts, textile machines, machine tools, photovoltaic installations, call centres, medical equipment, etc.

#### Hpi type - Special applications

Type Hpi RCCBs are devices which offer additional immunity to unwanted tripping which significantly exceeds the level required by the standard. They are also able to detect AC and DC residual currents (A type). Operation between - 25 °C and + 40 °C. They are used in special applications where:

- Loss of information is potentially damaging, e.g. power supply lines for computer equipment (banks, equipment on military bases, flight reservation centres, etc.)
- Loss of operation is potentially damaging (automated machinery, medical equipment, freezer cable, etc.)

They are also used:

- On sites where there is an increased risk of lightning strikes (see p. 66)
- On sites where cables are subject to high levels of interference (use of fluorescents, etc.)
- On sites where very long cables are used

## Dimensions of din-rail equipment

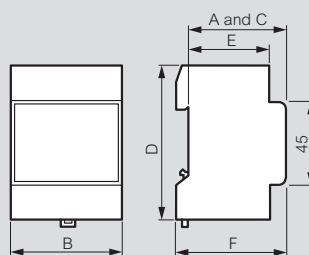
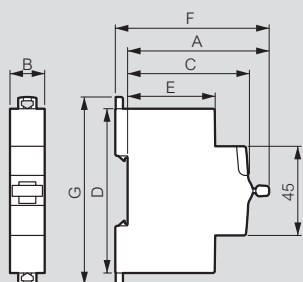

Product	A		B				C	D	E	F	G
	1P	1P+ N	2P	3P	4P						
<b>RX<sup>3</sup> MCBs</b>	71.7	17.7	35.4	35.4	53.1	70.8	61	83	44	77.8	88.9
<b>RX<sup>3</sup> RCCBs</b>	71.7			35.6		71.2	61	83	44	77.8	88.9
<b>TX<sup>3</sup> MCBs</b>	71.7	17.7	35.4	35.4	53.1	70.8	61	83	44	77.8	88.9
<b>TX<sup>3</sup> RCCBs</b>	71.7			35.6		71.2	61	83	44	77.8	88.9
<b>Isolating switches DX<sup>3</sup></b>	71.7	17.8		17.8/ 35.4	35.6/ 53.1	70.8	61	83	44	77.8	94.8
<b>Remote trip head isolating switches DX<sup>3</sup> up to 63A - 1 mod/pole</b>	71.7			35.4	53.1	70.8	61	83	44	77.9	94.8
<b>Remote trip head isolating switches DX<sup>3</sup> 100/125A - 1.5 mod/pole</b>	73				80.1	106.8	61	96	47	79	104.3
<b>DX<sup>3</sup> RCCBs</b>	71.7			35.6		71.2	61	83	44	77.8	94.8
<b>1P DX<sup>3</sup> RCBOs (up to 45A)</b>	68	17.7					60	115	48	74	126.8
<b>1P+N DX<sup>3</sup> RCBOs (up to 40A) &amp; 4P (up to 32A)</b>	71.7		35.6			71.2	61	83	44	77.8	94.8
<b>2P &amp; 4P DX<sup>3</sup> RCBOs (40A to 63A)</b>	72			71.2		124.6	61	96	44	78.2	107.8
<b>1P+N DX<sup>3</sup> MCBs 1 mod</b>	71.7		17.8				61	83	44	77.8	94.8
<b>DX<sup>3</sup> MCBs - 1 mod/pole</b>	71.7	17.7	35.4	35.4	53.1	70.8	61	83	44	77.8	94.8
<b>DX<sup>3</sup> MCBs - 1,5 mod/pole</b>	73.1	26.7		53.4	80.1	106.8	61	100	47	79	104.3
<b>DX<sup>3</sup> add-on modules up to 63A - 1 mod/pole</b>	72			35.6	53.4	53.4	61	96	44	78.2	107.8
<b>DX<sup>3</sup> add-on modules up to 63A - 1.5 mod/pole</b>	72			35.6	53.4	53.4	61	96	47	78.2	116.7
<b>DX<sup>3</sup> add-on modules 80 to 125A - 1.5 mod/pole</b>	72			71.2	106.8	106.8	61	114	47	78.2	129
<b>DX<sup>3</sup> auxiliaries</b>	71.5			8.8 / 17.7			61	83	44	77.7	84.5
<b>DX<sup>3</sup> remote control</b>	74.3			17.7 / 35.4			61	83	44	80.5	98.8
<b>DX<sup>3</sup> Stop&amp;Go automatic resetting</b>	74.3			35.4			61	83	44	80.5	113.7
<b>Change-over switches</b>	68	17.7		35.6			60	83	44	74	94
<b>CX<sup>3</sup> latching relays</b>	64	17.8		17.8	35.6	35.6	61	84.5	44	70.2	94.8
<b>CX<sup>3</sup> contactors up to 25A</b>	66.3/ 61	17.8		17.8	35.6	35.6	61	84.5	44	72.6/ 67.3	94.8
<b>CX<sup>3</sup> contactors 40A &amp; 63A</b>	62			35.6	53.4	53.4	60	83	44	68	94
<b>Auxiliaries for CX<sup>3</sup> contactors and latching relays</b>	61			9/17.8			61	84.5	44	67	84.5
<b>Push-buttons / control switches</b>	68			17.7			60	83	44	74	94
<b>Indicators</b>	68			17.7			60	83	44	69	94
<b>Bells and buzzers</b>	60			17.7			60	76	44	66	85
<b>Light sensitive switches</b>											
<b>Cat.Nos 0 037 21, 4 126 23</b>	60			35.6			60	85	37.5	66	70
<b>Socket outlets</b>	60			44.5			60	83	44	66	92
<b>Time delay relays</b>	60			17.7			60	83	44	66	94
<b>Remote control dimmers</b>											
<b>Cat.No 0 036 58</b>	60			36			60	83	44	66	94
<b>Cat.No 0 036 60</b>	60			72			60	83	44	66	94
<b>Cat.No 0 036 71</b>	60			108			60	83	44	66	94

Description	A	B	C	D	E	F
<b>Programmable time switches</b>						
<b>0 037 05</b>	60	17.8	60	83	44	66
<b>4 127 80/90/94</b>	60	17.8	60	83	44	66
<b>4 127 95, 4 128 12/13</b>	60	53	60	83	44	66
<b>4 126 31/33/41</b>	60	35.6	60	83	44	66
<b>4 126 54/57</b>	60	35.6	60	83	44	66
<b>0 047 70</b>	60	90	60	83	44	66
<b>Transformers and power supplies</b>						
<b>0 042 10/30/31</b>	60	72	60	83	44	66
<b>4 130 91</b>	60	35.8	60	83.5	44	66
<b>4 130 92/93/96</b>	60	71.5	60	83.5	44	66
<b>4 130 98</b>	60	89	60	94	44	66
<b>0 047 91/92</b>	60	105	60	95	44	66
<b>4 131 05/06/07/08</b>	60	89	60	95	44	66
<b>0 047 93</b>	60	70	60	95	44	66
<b>Residual current relay</b>						
<b>0 260 88</b>	60	35.5	60	89	44	66

## DX<sup>3</sup> RCCBs - ID 2P up to 100 A

Cat. N°(s) : 4 115 00, 04, 05, 06, 07, 08, 14, 15, 16, 17, 24,  
4 115 25, 26, 27, 28, 37, 43, 50, 54, 55, 56, 57, 69, 70, 71,  
4 115 72, 84, 90, 91, 92



CONTENTS	PAGE
1. Description, use.....	1
2. Range .....	1
3. Overall dimensions.....	1
4. Preparation - Connection.....	1
5. General characteristics.....	3
6. Compliance and approvals .....	8
7. Curves.....	9
8. Auxiliaries and accessories .....	11
9. Safety.....	11

### 1. DESCRIPTION - USE

RCCBs with positive contact indication for control, protection and isolation of electrical circuits, protecting people from direct and indirect contact and protecting installations from insulation faults.

#### Symbol:

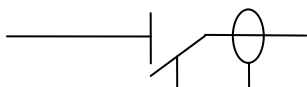

#### Technology:

. Electromagnetic residual current function with current-sensing relay

### 2. RANGE

#### Polarity:

. 2-pole

#### Width:

. 2 modules (2 x 17.8 mm)

#### Nominal rating In:

. 16 / 25 / 40 / 63 / 80 / 100 A

#### Residual current types:

- . AC (sinusoidal differential alternating currents)
- . A (residual currents with a DC component)
- . AC-S and A-S (discriminating)
- . HPI (immunised against false tripping). HPI products are also A type.

#### Sensitivity:

. 10 / 30 / 100 / 300 mA

#### Nominal voltage and frequency:

. 230 V~ / 240 V~, 50 Hz with standard tolerances

#### Maximum operating voltage:

. 250 V ~, 50 Hz

### 3. OVERALL DIMENSIONS

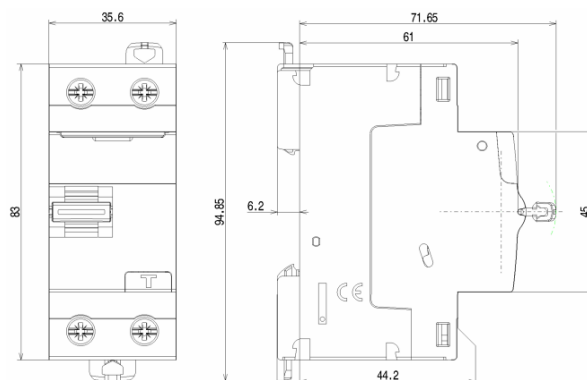

### 4. PREPARATION - CONNECTION

#### Mounting:

. On symmetrical rail EN 60715 or DIN 35 rail

#### Operating positions:

. Vertical      Horizontal      Upside down      On the side

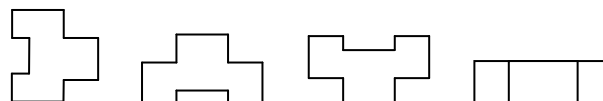

#### Power supply:

. From the top or the bottom

#### Connection:

. Inputs and outputs via screw terminals

#### Terminal arrangement:

- . Cage terminals, with disengageable and captive screws (fitted with flaps preventing a cable being placed under the terminal, with the terminal partly open or closed)
- . Terminals protected against direct finger contact IP20, wired

# DX<sup>3</sup> RCCBs - ID

## 2P up to 100 A

Cat. N°(s) : 4 115 00, 04, 05, 06, 07, 08, 14, 15, 16, 17, 24,  
4 115 25, 26, 27, 28, 37, 43, 50, 54, 55, 56, 57, 69, 70, 71,  
4 115 72, 84, 90, 91, 92

### 4. PREPARATION - CONNECTION *(continued)*

. A circuit breaker may be replaced in the middle of a row supplied with busbars without disconnecting the other products

Put the lugs in the unlocking position

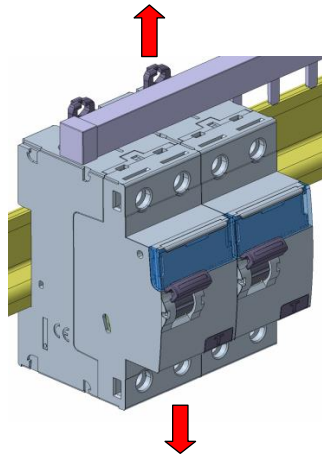

Put the latch clips in the unlocking position

Unscrew the four upper terminals completely

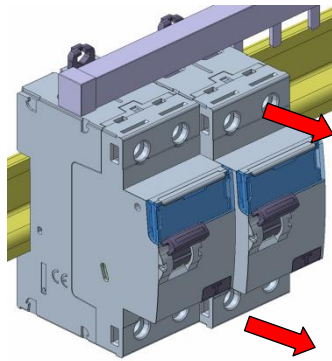

Pull the device forward in order to release it from the rail

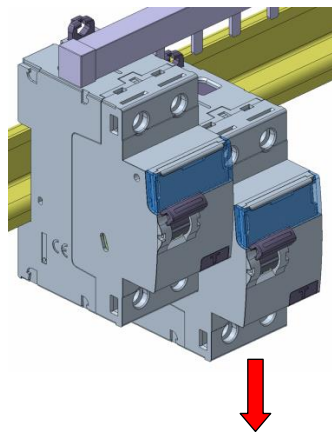

Pull the device downward in order to release it completely from the prongs of the busbar

#### Connection:

- . Terminals protected against direct finger contact IP20, wired device
- . Cage terminals, with disengageable or captive screws
- . Terminals fitted with flaps preventing a cable being placed under the terminal, with the terminal partly open or closed
- . Alignment and spacing of the terminals permitting connection with the other products in the range via toothed supply busbars

### 4. PREPARATION - CONNECTION *(continued)*

#### Terminal arrangement: *(continued)*

- . Alignment and spacing of the terminals permitting shutters with the other products via toothed supply busbars
- . Terminal depth: 14 mm
- . Terminal capacity: 60 mm<sup>2</sup>
- . Screw head: mixed head, slotted head and Philips / Pozidriv no. 2
- . Tightening torques:
  - Minimum / Maximum: 1.2 Nm / 3.5 Nm
  - Recommended: 2.5 Nm

#### Conductor types:

- . Copper cables at the top and bottom of the product
- Cable cross-section:

	Without ferrule	With ferrule
Rigid cable	1 x 0.75 to 50 mm <sup>2</sup> or 2 x 0.75 to 16 mm <sup>2</sup>	/
Flexible cable	1 x 0.75 to 35 mm <sup>2</sup> or 2 x 0.75 to 16 mm <sup>2</sup>	1 x 0.75 to 25 mm <sup>2</sup>

#### Required tools:

- . For the terminals:
  - 5.5 mm / 6.5 mm blade screwdriver recommended
  - Pozidriv n°2 / Philips N°2 screwdriver recommended
- . For the latching:
  - 5.5 mm blade screwdriver recommended / 6 mm maximum
  - Pozidriv n°2 / Philips N°2 screwdriver recommended

#### Device handling:

- . Manual action via ergonomic 2 position handle:
  - I-On, device closed O-Off, device open

#### Contact status display:

- . By marking of the handle:
  - I-On, in white on a red background: closed contacts
  - O-Off, in white on a green background: contacts open

#### Residual current trip display:

- . Handle at the bottom position, the residual current is released

#### Lockout:

- . Padlocks possible in the open or closed positions with padlock support (Cat. No. 4 063 03) and Ø5 mm padlock (Cat. No. 4 063 13) or Ø6 mm padlock (Cat. No. 227 97)

#### Sealing:

- . Possible in the open or closed positions

#### Labelling:

- . Circuit identification by way of a label inserted in the label holder situated on the front of the product





# DX<sup>3</sup> RCCBs - ID

## 2P up to 100 A

Cat. N°(s) : 4 115 00, 04, 05, 06, 07, 08, 14, 15, 16, 17, 24,  
4 115 25, 26, 27, 28, 37, 43, 50, 54, 55, 56, 57, 69, 70, 71,  
4 115 72, 84, 90, 91, 92

### 5. GENERAL CHARACTERISTICS

#### Neutral earthing system:

. IT, TT and TN

#### Marking:

. Marking on the "front side": (by permanent ink pad printing)



#### Marking on the upper panel:

. By permanent ink pad printing

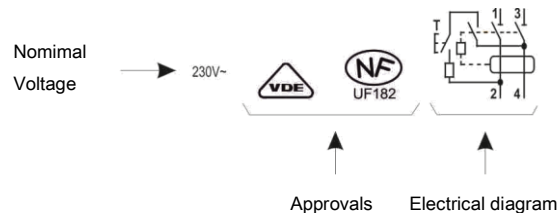

#### Test operating voltage:

- . 10 mA all types : from 110 V to 250 V~
- . 30 mA, all types: from 180 V to 250 V~
- . 100 mA AC type : from 110 V to 250 V ~
- . 300 mA A / S type : from 110 V to 250 V~
- . 300 mA AC type : from 115 V to 250 V ~
- . 100 mA S type : from 120 V to 250 V ~

#### Rated conditional short-circuit current:

.  $I_{nc} = 10$  kA, in accordance with EN/IEC 61008-1

#### Rated conditional short-circuit residual current:

.  $I_{\Delta c} = 10$  kA, in accordance with EN/IEC 61008-1

#### Rated residual breaking capacity:

.  $I_{\Delta m} = 1000$  A, in accordance with EN/IEC 61008-1

#### Rated breaking and making capacity:

In accordance with EN/IEC 61008-1,

- .  $I_n = 16 / 25 / 40$  A :  $I_m = 500$  A
- .  $I_n = 63$  A :  $I_m = 630$  A
- .  $I_n = 80$  A :  $I_m = 800$  A
- .  $I_n = 100$  A :  $I_m = 1,000$  A

#### Protection against overloads:

. The RCCB must be protected against overloads (either upstream or downstream) by a circuit breaker or a fuse which has a maximum of the same nominal current as the residual current switch



# DX<sup>3</sup> RCCBs - ID

## 2P up to 100 A

Cat. N°(s) : 4 115 00, 04, 05, 06, 07, 08, 14, 15, 16, 17, 24,  
4 115 25, 26, 27, 28, 37, 43, 50, 54, 55, 56, 57, 69, 70, 71,  
4 115 72, 84, 90, 91, 92

### 5. GENERAL CHARACTERISTICS *(continued)*

#### Protection against short-circuits:

. The RCCB must be protected upstream against short circuits using a circuit breaker or a fuse. Its resistance to short circuits when associated with a Legrand circuit breaker or fuse is compliant with the values stated in the tables below:

. Association with a fuse:

Downstream	Upstream			
RCCB	gG or aM type fuse			
Rating	≤ 50 A	63 A	80 A	≥ 100 A
16 A to 100 A	<b>100 kA</b>	<b>50 kA</b>	<b>15 kA</b>	<b>10 kA</b>

. Association with a circuit breaker:

		Upstream circuit breaker			
		DX <sup>3</sup> 4500 / 6 kA P+N 1 mod	DX <sup>3</sup> 4500 / 6 kA 3P / 4P 3 mod	DX <sup>3</sup> 6000 / 10 kA P+N 1 mod	DX <sup>3</sup> 6000 / 10 kA
Downstream RCCB	Curves	C	C	B & C	B, C & D
	In	≤ 40 A	≤ 32 A	≤ 40 A	≤ 63 A
2P - 230 V~	16 A à 100 A	<b>6 kA</b>	<b>10 kA</b>	<b>10 kA</b>	<b>16 kA</b>

		Upstream circuit breaker				
		DX <sup>3</sup> 10000 / 16 kA P+N 1 mod	DX <sup>3</sup> 10000 / 16 kA	DX <sup>3</sup> 25 kA	DX <sup>3</sup> 36 kA	DX <sup>3</sup> 50 kA
Downstream RCCB	Curves	C	B, C & D	B, C & D	C	B, C & D
	In	≤ 20 A	≤ 125 A	≤ 125 A	≤ 80 A	≤ 63 A
2P - 230 V~	16 A à 100 A	<b>16 kA</b>	<b>25 kA</b>	<b>36 kA</b>	<b>50 kA</b>	<b>70 kA</b>

		Upstream circuit breaker			
		DPX <sup>3</sup> 160 / DPX <sup>3</sup> 160 + residual current			
		16 kA	25 kA	36 kA	50 kA
Downstream RCCB	In	≤ 160 A	≤ 160 A	≤ 160 A	≤ 160 A
	2P - 230 V~	16 A à 100 A	<b>25 kA</b>	<b>36 kA</b>	<b>36 kA</b>

# DX<sup>3</sup> RCCBs - ID

## 2P up to 100 A

Cat. N°(s) : 4 115 00, 04, 05, 06, 07, 08, 14, 15, 16, 17, 24,  
4 115 25, 26, 27, 28, 37, 43, 50, 54, 55, 56, 57, 69, 70, 71,  
4 115 72, 84, 90, 91, 92

### 5. GENERAL CHARACTERISTICS (continued)

#### Protection against short circuits (continued):

. Association with circuit breakers: case of a double fault, in IT system – Resistance to the lcc of a single pole

Downstream RCCB	Circuit breaker upstream		
	DNX <sup>3</sup> P+N 1 mod	DX <sup>3</sup> P+N 1 mod	DX <sup>3</sup> 3P / 4P 3 mod
	4500 A / 4,5 kA	4500 A / 6 kA	
At 230 V	<b>4,5 kA</b>	<b>4,5 kA</b>	<b>4,5 kA</b>
At 400 V	<b>1,5 kA</b>	<b>1,5 kA</b>	<b>3 kA</b>

Downstream RCCB	Circuit breaker upstream		
	DX <sup>3</sup> P+N 1 mod	DX <sup>3</sup> 3P / 4P 3 mod	DX <sup>3</sup> 1P / 2P / 3P / 4P
	6000 A / 10 kA		
At 230 V	<b>4,5 kA</b>	<b>6 kA</b>	<b>10 kA</b>
At 400 V	<b>3 kA</b>	<b>3 kA</b>	<b>3 kA</b>

Downstream RCCB	Circuit breaker upstream				
	DX <sup>3</sup> P+N 1 mod	DX <sup>3</sup> 1P / 2P / 3P / 4P	DX <sup>3</sup> 1P / 2P / 3P / 4P	DX <sup>3</sup> 1P / 2P / 3P / 4P	DX <sup>3</sup> 1P / 2P / 3P / 4P
	10000 A / 16 kA	25 kA	36 kA	36 kA	
At 230 V	<b>6 kA</b>	<b>16 kA</b>	<b>25 kA</b>	<b>36 kA</b>	<b>50 kA</b>
At 400 V	<b>3 kA</b>	<b>4 kA</b>	<b>6,25 kA</b>	<b>9 kA</b>	<b>12,5 kA</b>

# DX<sup>3</sup> RCCBs - ID

## 2P up to 100 A

Cat. N°(s) : 4 115 00, 04, 05, 06, 07, 08, 14, 15, 16, 17, 24,  
4 115 25, 26, 27, 28, 37, 43, 50, 54, 55, 56, 57, 69, 70, 71,  
4 115 72, 84, 90, 91, 92

### 5. GENERAL CHARACTERISTICS *(continued)*

Power dissipated by the device:

RCCB		Power dissipated by the device (In)				
In	Sensibilité	AC type	A type	AC-S type	A-S type	A-HPI type
16 A	10 mA	0,8 W	0,8 W			
25 A	30 mA	1,6 W	1,5 W			0,5 W
25 A	100 mA	0,5 W				
25 A	300 mA	0,5 W	0,5 W			
40 A	30 mA	4 W	4 W			1,2 W
40 A	100 mA	1,3 W				
40 A	300 mA	1,3 W	1,3 W			
63 A	30 mA	3,1 W	3,1 W			3 W
63 A	100 mA	3,1 W				
63 A	300 mA	3,1 W	3,1 W	3 W	3 W	
80 A	30 mA	5 W	5 W			
80 A	100 mA	5 W				
80 A	300 mA	5 W	5 W			
100 A	30 mA	7,5 W				
100 A	100 mA			7,5 W		
100 A	300 mA	7,5 W				

### Temperature derating:

. Reference temperature: 30°C in accordance with standard IEC/EN 61008-1

In (A)	Ambient Temperature/In								
	- 25°C	- 10°C	0°C	10°C	20°C	30°C	40°C	50°C	60°C
16 A	16	16	16	16	16	16	16	16	16
25 A	25	25	25	25	25	25	25	25	25
40 A	40	40	40	40	40	40	40	25	25
63 A	63	63	63	63	63	63	63	40	40
80 A	80	80	80	80	80	80	80	63	63
100 A	100	100	100	100	100	100	100	80	80

# DX<sup>3</sup> RCCBs - ID

## 2P up to 100 A

Cat. N°(s) : 4 115 00, 04, 05, 06, 07, 08, 14, 15, 16, 17, 24,  
4 115 25, 26, 27, 28, 37, 43, 50, 54, 55, 56, 57, 69, 70, 71,  
4 115 72, 84, 90, 91, 92

### 5. GENERAL CHARACTERISTICS (continued)

#### Weight per device:

Référence	Catalogue Number	Weight (kg)
411 500	16 A AC type 10 mA	0,18
411 504	25 A AC type 30 mA	0,19
411 505	40 A AC type 30 mA	0,19
411 506	63 A AC type 30 mA	0,22
411 507	80 A AC type 30 mA	0,22
411 508	100 A AC type 30 mA	0,20
411 514	25 A AC type 100 mA	0,22
411 515	40 A AC type 100 mA	0,22
411 516	63 A AC type 100 mA	0,22
411 517	80 A AC type 100 mA	0,22
411 524	25 A AC type 300 mA	0,18
411 525	40 A AC type 300 mA	0,18
411 526	63 A AC type 300 mA	0,19
411 527	80 A AC type 300 mA	0,18
411 528	100 A AC type 300 mA	0,19
411 537	100 A AC-S type 100 mA	0,20
411 543	63 A AC-S type 300 mA	0,21
411 550	16 A A type 10 mA	0,19
411 554	25 A A type 30 mA	0,22
411 555	40 A A type 30 mA	0,22
411 556	63 A A type 30 mA	0,22
411 557	80 A A type 30 mA	0,21
411 569	25 A A type 300 mA	0,19
411 570	40 A A type 300 mA	0,19
411 571	63 A A type 300 mA	0,19
411 572	80 A A type 300 mA	0,19
411 584	63 A A-S type 300 mA	0,22
411 590	25 A HPI type 30 mA	0,21
411 591	40 A HPI type 30 mA	0,21
411 592	63 A HPI type 30 mA	0,21

### 5. GENERAL CHARACTERISTICS (continued)

#### Packaged volume and quantity:

	Volume (dm <sup>3</sup> )	Packaging
For all catalogue numbers	0.35	per unit

#### Isolation distance: (distance between the contacts)

- . Handle in open position - O-Off:  
Greater than 4.5 mm

#### Rated insulation voltage:

- . U<sub>i</sub> = 250 V

#### Insulation resistance:

- . 2 MΩ

#### Degree of pollution:

- . 2

#### Dielectric strength:

- . 2000 V - 50 Hz

#### Impulse withstand voltage:

- . U<sub>imp</sub> = 4 kV

#### Protection from false tripping:

- . 0.5 μs/100 kHz damped recurring wave = 200 A
- . 8/20 μs wave:
  - A / AC type = 250 A
  - AC-S / A-S and Hpi type = 3000 A

#### Protection classes:

- . Terminals protected against direct contact:
  - IP20 (wired device)
- . Front side protected against direct contact:
  - IP40
- . Class II in relation to metallic conductive parts
- . Protection against impacts:
  - IK04

#### Plastic materials used:

- . Parts made of polyamide and P.B.T.

#### Enclosure heat and fire resistance:

- . Resistance to incandescent wire tests at 960°C, in accordance with standard IEC/EN 61008-1
- . Classification V2, in accordance with standard UL94

#### Device's upper heating value:

- . Estimated heating value of a 25 or 40A 30mA AC device:  
2.41 MJ

#### Handle opening and closing forces:

- . Force of 23 N for closing - (all ratings)
- . Force of 8 N for opening - (all ratings)

# DX<sup>3</sup> RCCBs - ID

## 2P up to 100 A

Cat. N°(s) : 4 115 00, 04, 05, 06, 07, 08, 14, 15, 16, 17, 24,  
4 115 25, 26, 27, 28, 37, 43, 50, 54, 55, 56, 57, 69, 70, 71,  
4 115 72, 84, 90, 91, 92

### 5. GENERAL CHARACTERISTICS *(continued)*

#### Mechanical endurance:

- . Conforms to standard NF EN 61008-1
- . Tested with 20,000 operations with no load

#### Electrical endurance:

- . Conforms to standard NF EN 61008-1
- . Tested with 10,000 operations with load (at  $I_n \times \cos \varphi 0.9$ )
- . Tested with 2,000 residual current trip operations using the test button or the fault current

#### Operating ambient temperature:

- . - 25°C / + 60°C

#### Storage temperature:

- . - 40°C / + 70°C

#### Specific use:

Appropriate to operate in humid atmosphere and polluted by a chlorinated environment (pool-type)

#### Derating of RCCBs function of the number of devices placed side by side:

When several RCCBs are installed side by side and operate simultaneously, the heat dissipation of one pole is limited. This results in an increased operating temperature for the RCCBs which may cause false tripping. Applying the following coefficients to the operating currents is recommended.

Number of circuit breakers side by side	Coefficient
2 - 3	<b>0.9</b>
4 - 5	<b>0.8</b>
6 - 9	<b>0.7</b>
≥ 10	<b>0.6</b>

These values are provided by recommendation IEC 60439-1 and the standards NF C 63421 and EN 60439-1.

In order to avoid having to use these coefficients there must be good ventilation and the devices must be kept apart using the spacing elements Cat. No. 4 063 07 (0.5 module).

#### Impact of height:

	2,000 m	3,000 m	4,000 m	5,000 m
Dielectric strength	<b>2,000 V</b>	<b>2,000 V</b>	<b>2,000 V</b>	<b>1,500 V</b>
Maximum operating voltage	<b>400 V</b>	<b>400 V</b>	<b>400 V</b>	<b>400 V</b>
Derating at 30°C	<b>none</b>	<b>none</b>	<b>none</b>	<b>none</b>

### 5. GENERAL CHARACTERISTICS *(continued)*

#### DC operation:

- . Cannot be used with DC

#### Operation at 400 Hz:

- . Cannot be used at 400 Hz

#### Operation at 60 Hz:

Can be used at 60Hz, except ratings 63A/80A, A and AC types, with sensitivity 30mA, which can be replaced by HPI types of equivalent ratings and sensitivity.

#### Resistance to sinusoidal vibrations: (in accordance with IEC 68.2.6)

- . Axes: x / y / z
- . Frequency: 10 to 55 Hz
- . Acceleration: 3 g (1 g = 9.81 m.s<sup>-2</sup>)

#### Resistance to tremors :

- . Conforms to standard NF EN 61008-1

### 6. COMPLIANCE AND APPROVALS

#### Reference product standards:

- . NF EN 61008-1/IEC 61008-1
- . EN/IEC 60 529 (IP)

#### Environment:

- . Compliance with European Union Directives
- . Compliance with Directive 2002/95/EC of 27/01/03 known as "RoHS" which provides for a restriction on the use of dangerous substances such as lead, mercury, cadmium, hexavalent chromium and polybrominated biphenyl (PBB) and polybrominated diphenyl ether (PBDE) brominated flame retardants from 1st July 2006
- . Compliance with the Directive 91/338/EEC of 18/06/91 and decree 94-647 of 27/07/94

#### Usage in special conditions:

- . Category C compliant (testing temperature of -25°C to +70°C, resistant to salt spray) in accordance with the classification defined in Appendix Q of standard IEC/EN 60947-1

#### Plastic materials:

- . Zero halogen plastic materials.
- . Labelling compliant with ISO 11469 and ISO 1043.

#### Packaging:

- . Design and manufacture of packaging compliant with decree 98-638 of 20/07/98 and Directive 94/62/EC

**7. CURVES**

**Tripping current curves:**

. Tripping time curve depending on the value of the fault current:

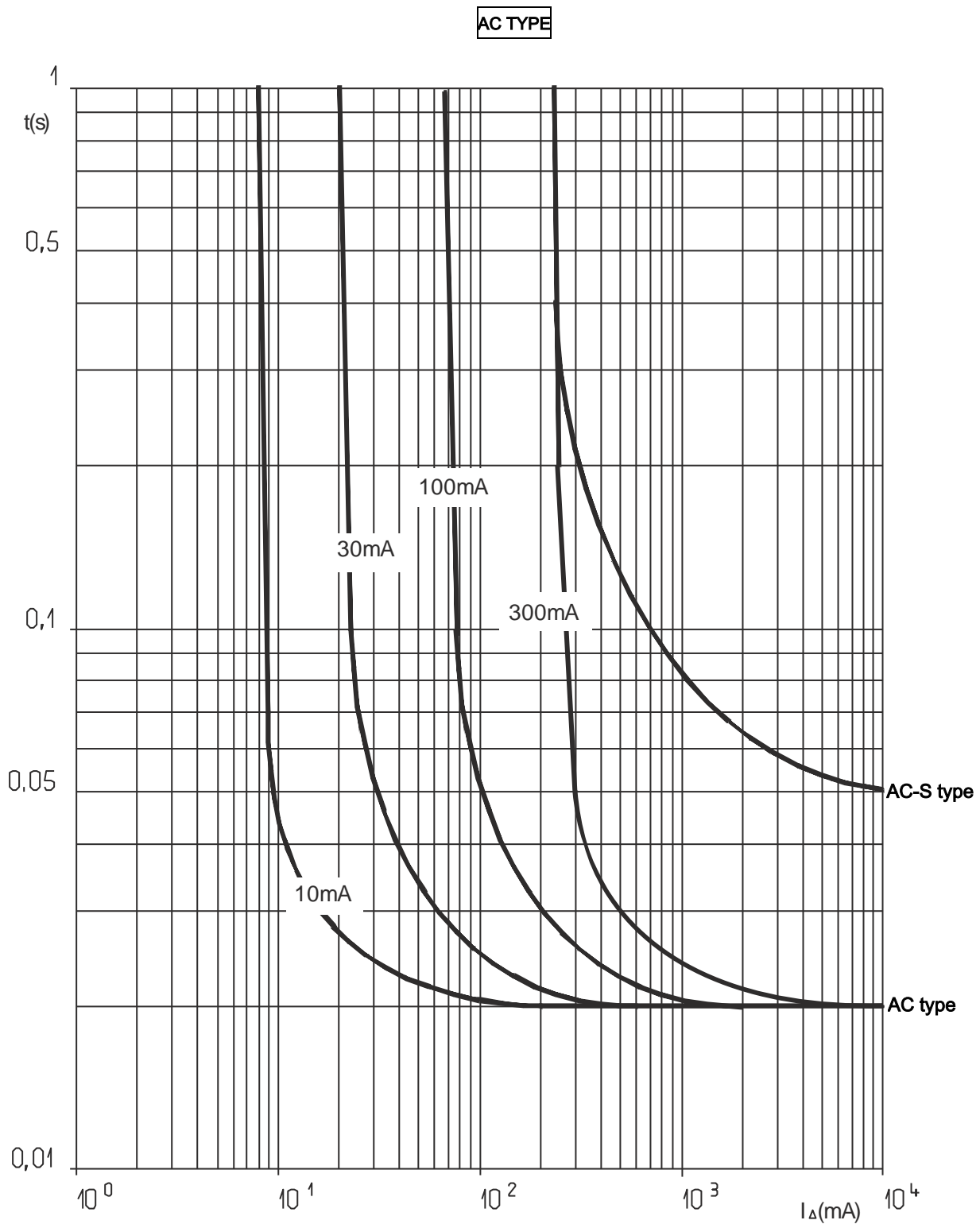

**7. CURVES (continued)**

**Tripping current curves:**

. Tripping time curve depending on the value of the fault current:

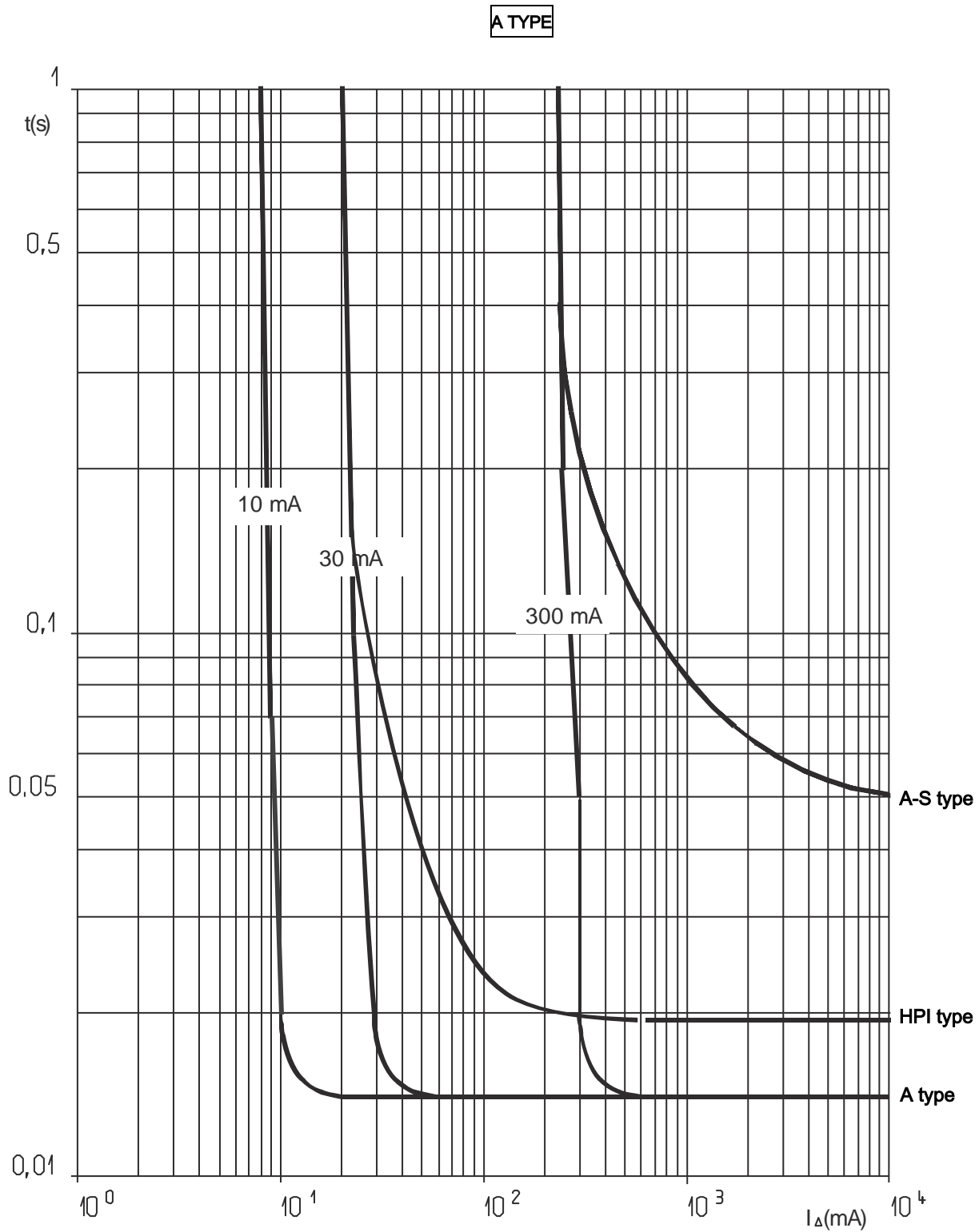



# DX<sup>3</sup> RCCBs - ID

## 2P up to 100 A

Cat. N°(s) : 4 115 00, 04, 05, 06, 07, 08, 14, 15, 16, 17, 24,  
4 115 25, 26, 27, 28, 37, 43, 50, 54, 55, 56, 57, 69, 70, 71,  
4 115 72, 84, 90, 91, 92

### 8. AUXILIARIES AND ACCESSORIES

#### Wiring accessories:

- . Sealable screw cover (Cat. No. 4 063 04)
- . Supply busbar:
  - HX<sup>3</sup> 2-pole supply busbar
- . Terminal for aluminium cable with max. 50 mm<sup>2</sup> cross-section (Cat. No. 4 063 10)

#### Signalling auxiliaries:

- . Auxiliary contact (0.5 module, Cat. No. 4 062 58)
- . Fault signalling contact (0.5 module, Cat. No. 4 062 60)
- . Auxiliary contact that can be changed into fault signalling contact (0.5 module, Cat. No. 4 062 62)
- . Auxiliary contact + fault signalling contact that can be changed into 2 auxiliary contacts (1 module, Cat. No. 4 062 66)

#### Control auxiliaries:

- . Shunt trip (1 module, Cat. No. 4 062 76, 2 78)
- . Undervoltage release (1 module, Cat. No. 4 062 80, 2 82)
- . Stand-alone release for N/C push-button (1.5 module, Cat. No. 4 062 87)

#### Motorised controls:

- . Motor-driven control (1 module, Cat. No. 4 062 91)
- . Motor-driven control with integrated automatic reset (2 modules, Cat. Nos. 4 062 93, 2 95)

#### Possible combinations of auxiliaries and RCCBs:

- . The auxiliaries are installed to the left of the RCCBs
- . Maximum number of auxiliaries = 3
- . Maximum number of 1 module signalling auxiliaries = 2
- . Maximum number of control auxiliaries (Cat. Nos. 4 062 76 to 4 062 87) = 1
- . The control auxiliary (trip Cat. Nos. 4 062 76 to 4 062 87) must mandatorily be placed to the left of the signalling auxiliaries (Cat. Nos. 4 062 58 to 4 062 66) where the auxiliaries from these 2 families are connected to the same RCCB

#### Sealing:

- . Possible in the open or closed positions

#### Lockout possibilities:

- . Via Ø 5 mm padlock (Cat. No. 4 063 13) or Ø 6 mm padlock (Cat. Nos. 0 227 97) and padlock support (Cat. No. 4 063 03)

#### Installation software:

- . XL PRO<sup>3</sup>

### 9. SAFETY

. For your safety your electrical installation is equipped with residual current protection and this must be tested periodically. In the absence of any national regulations on the time period required for this, Legrand recommends that this test be carried out every month: press the "T" test button, the device should trip. Please call an electrician immediately if this does not happen as your installation's safety level has been reduced

. The presence of residual current protection does not remove the need to observe all the precautions associated with using electrical energy