

# Power contactors with handle CX<sup>3</sup>

from 16 A to 63 A

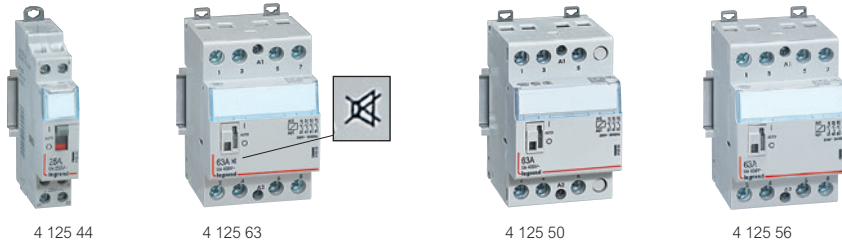

Dimensions **see e-catalogue**  
 Technical characteristics **p. 80**

Conform to IEC/EN 61095  
 Space for power supply busbar on top (up to 25 A)

Pack	Cat.Nos	<b>Power contactors with 24 V~ coil and handle</b>			
		Manual override for test and repair function, carried out via the handle Permanent "ON" or "OFF" without automatic reset			
		<b>2-pole - 250 V~</b>			
1	4 125 14	I max 25 A		Type of contact 2 N/O	Number of modules 1
1	4 125 15 <sup>1</sup>	40 A		2 N/O	2
1	4 125 16 <sup>1</sup>	63 A		2 N/O	2
		<b>4-pole - 400 V~</b>			
1	4 125 17	25 A		4 N/O	2
1	4 125 18 <sup>1</sup>	40 A		4 N/O	3
1	4 125 19 <sup>1</sup>	63 A		4 N/O	3
		<b>Low noise power contactors with 230 V~ coil and handle</b>			
		<b>2-pole - 250 V~</b>			
1	4 125 58	I max 25 A		Type of contact 2 N/O	Number of modules 1
1	4 125 59 <sup>1</sup>	40 A		2 N/O	2
1	4 125 60 <sup>1</sup>	63 A		2 N/O	2
		<b>4-pole - 400 V~</b>			
1	4 125 61	25 A		4 N/O	1
1	4 125 62 <sup>1</sup>	40 A		4 N/O	2
1	4 125 63 <sup>1</sup>	63 A		4 N/O	2

Pack	Cat.Nos	<b>Power contactors with 230 V~ coil and handle</b>				
		Manual override for test and repair function, carried out via the handle Permanent "ON" or "OFF" without automatic closing of the contactor				
		<b>2-pole - 250 V~</b>				
4	4 125 44	I max 25 A		Type of contact 2 N/O	Number of modules 1	
1	4 125 45 <sup>1</sup>	40 A		2 N/O	2	
1	4 125 47 <sup>1</sup>	63 A		2 N/O	2	
1	4 125 48 <sup>1</sup>	63 A		2 N/C	2	
		<b>3-pole - 400 V~</b>				
1	4 125 49 <sup>1</sup>	40 A			3 N/O	3
1	4 125 50 <sup>1</sup>	63 A	3 N/O		3	
		<b>4-pole - 400 V~</b>				
2	4 125 51	25 A		4 N/O	2	
1	4 125 53 <sup>1</sup>	40 A		4 N/O	3	
1	4 125 56 <sup>1</sup>	63 A		4 N/O	3	
1	4 125 57 <sup>1</sup>	63 A		4 N/C	3	

1: Handle can be accessed after removing blanking plate

## Technical characteristics

- Rated impulse withstand voltage (Uimp): 4 kV
- Mechanical endurance (no. of operating cycles): 10<sup>6</sup> cycles
- Operating temperatures: - 25 °C to + 40 °C
- Storage temperatures: - 40 °C to + 70 °C

### Contactor protection against short circuits according to standard EN 61095, conditional short-circuit current:

- I<sub>q</sub> = 6 kA for 16 to 25 A contactors
- I<sub>q</sub> = 3 kA for 40 to 63 A contactors

Circuit breaker or gG fuse rated:

- ≤ 16 A for 16 A rating      • ≤ 40 A for 40 A rating
- ≤ 25 A for 25 A rating      • ≤ 63 A for 63 A rating

## Consumption of a contactor control coil

16 A and 25 A power contactors					
Coil voltage	24 V~		230 V~ low noise	230 V~	
Current	16 A and 25 A	25 A	25 A	16 A and 25 A	16 A and 25 A
Type of contact	NC + NO 2 NO	4 NO	2 NO	NC + NO 2 NO 2 NC	2 NC + 2 NO 4 NO 4 NC
Dimensions	1 mod.	2 mod.	1 mod.	1 mod.	2 mod.
Holding current	200 mA	300 mA	12 mA	20 mA	20 mA
Inrush current	970 mA	2500 mA	60 mA	90 mA	200 mA

40 A and 63 A power contactors				
Coil voltage	24 V~		230 V~	
Current	40 A and 63 A	40 A and 63 A	40 A and 63 A	40 A and 63 A
Type of contact	2 NO	4 NO	2 NO 2 NC	3 NO 4 NO 4 NC
Dimensions	2 mod.	3 mod.	2 mod.	3 mod.
Holding current	250 mA	270 mA	15 mA	30 mA
Inrush current	1750 mA	1500 mA	150 mA	200 mA

## Recommendations

Insert a spacing module (Cat.No 4 063 07 p. 61):  
 - every two contactors when the ambient temperature is below 40 °C  
 - every contactor when the ambient temperature is between 40 and 60 °C

Contactor rating	40 °C	50 °C	60 °C
le = 16 A	16 A	14 A	12 A
le = 25 A	25 A	22 A	20 A
le = 40 A	40 A	36 A	32 A
le = 63 A	63 A	57 A	50 A

## Max. connection cross-section in mm<sup>2</sup>

Conductor type	Ratings ≤ 25 A	Ratings 40 & 63 A
Rigid	6 <sup>2</sup> or 2 x 2.5 <sup>2</sup>	25 <sup>2</sup> or 2 x 10 <sup>2</sup>
Flexible	6 <sup>2</sup> or 2 x 2.5 <sup>2</sup>	25 <sup>2</sup> or 2 x 10 <sup>2</sup>
Flexible with single end cap	6 <sup>2</sup>	16 <sup>2</sup>
Flexible with double end cap	2 x 4 <sup>2</sup>	2 x 16 <sup>2</sup>

## Contactor selection charts (number of lamps per contactor)

### Incandescent lamps

Tungsten and halogen filaments 230 V~								
Nominal wattage	40 W	60 W	75 W	100 W	150 W	200 W	500 W	1000 W
16 A	45	30	24	19	13	10	4	2
25 A	60	48	38	30	20	15	6	3
40 A	96	77	61	48	32	24	10	5
63 A	154	123	97	77	51	38	15	8

ELV halogen bulbs with ferromagnetic ballast						ELV halogen bulbs with electronic ballast						
Nominal wattage	20 W	35 W	50 W	75 W	100 W	150 W	20 W	35 W	50 W	75 W	100 W	150 W
16 A	32	20	15	12	9	6	60	40	28	18	14	9
25 A	52	30	24	16	12	8	80	50	40	26	20	13
40 A	68	39	31	21	16	10	112	70	56	36	28	18
63 A	88	51	41	27	20	14	157	98	78	51	39	25

## Contactor selection charts (number of lamps per contactor)(continued)

### LED lamps

Nominal wattage	Non-dimmable LED lamps (without driver)									
	2 W	5 W	7 W	9 W	12 W	18 W	22 W	30 W	40 W	50 W
16A	16	16	16	16	16	15	14	12	10	9
25A	30	30	30	30	30	27	25	22	18	15
40A	90	90	85	85	85	80	75	65	50	37
63A	150	150	140	140	140	115	100	80	70	55

Nominal wattage	Dimmable LED lamps (equipped with driver)									
	2 W	5 W	7 W	9 W	12 W	18 W	22 W	30 W	40 W	50 W
16A	40	40	40	35	35	33	30	27	23	20
25A	65	65	65	60	60	56	51	45	33	30
40A	170	170	170	162	162	129	113	95	77	65
63A	265	265	265	260	260	214	176	139	121	105

### Fluorescent tubes with electronic ballast

Nominal wattage	Single fluorescent				Double fluorescent		
	18 W	30 W	36 W	58 W	2 x 18 W	2 x 36 W	2 x 58 W
16 A	72	42	36	22	36	20	12
25 A	110	68	58	36	56	30	19
40 A	165	102	87	54	84	45	29
63 A	248	153	131	81	126	68	43

Nominal wattage	Triple fluorescent (series compensated)		Quadruple fluorescent (series compensated)	
	3 x 14 W	3 x 18 W	4 x 14 W	4 x 18 W
16 A	34	26	26	20
25 A	46	38	37	28
40 A	62	51	52	39
63 A	84	69	73	55

Nominal wattage	Compact fluorescent with built-in electronic power supply				
	7 W	11 W	15 W	20 W	23 W
16 A	120	80	64	50	43
25 A	200	125	90	70	60
40 A	280	175	126	98	84
63 A	392	245	176	137	118

### Discharge lamps with compensation

Nominal wattage	Metal halogenide						Low pressure sodium vapour					
	35 W	70 W	100 W	150 W	250 W	400 W	18 W	35 W	55 W	90 W	135 W	180 W
16 A	10	6	5	3	2	1	12	6	5	3	2	2
25 A	15	9	7	5	3	2	20	10	7	5	3	3
40 A	23	14	11	8	5	3	30	15	11	8	5	5
63 A	34	20	16	11	7	5	45	23	16	11	7	7

Nominal wattage	High pressure sodium vapour					High pressure mercury vapour				
	70 W	150 W	250 W	400 W	1000 W	50 W	80 W	125 W	250 W	400 W
16 A	8	7	5	3	1	11	8	6	3	2
25 A	10	9	6	4	2	15	10	8	4	3
40 A	15	14	9	6	3	21	14	11	6	4
63 A	23	20	14	9	5	29	20	16	8	6

Nominal wattage	High pressure mixed			
	100 W	160 W	250 W	400 W
16 A	9	6	4	2
25 A	11	7	5	3
40 A	14	9	7	4
63 A	19	12	8	5

Fluorescent lamps with ferromagnetic ballast, **please consult us**

# Dimensions of din-rail equipment

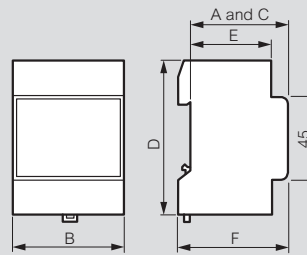
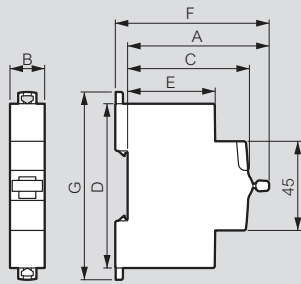

Product	A		B				C	D	E	F	G
	1P	1P+ N	2P	3P	4P						
<b>RX<sup>3</sup> MCBs</b>	71.7	17.7	35.4	35.4	53.1	70.8	61	83	44	77.8	88.9
<b>RX<sup>3</sup> RCCBs</b>	71.7			35.6		71.2	61	83	44	77.8	88.9
<b>TX<sup>3</sup> MCBs</b>	71.7	17.7	35.4	35.4	53.1	70.8	61	83	44	77.8	88.9
<b>TX<sup>3</sup> RCCBs</b>	71.7			35.6		71.2	61	83	44	77.8	88.9
<b>Isolating switches DX<sup>3</sup></b>	71.7	17.8		17.8/ 35.4	35.6/ 53.1	70.8	61	83	44	77.8	94.8
<b>Remote trip head isolating switches DX<sup>3</sup> up to 63A - 1 mod/pole</b>	71.7			35.4	53.1	70.8	61	83	44	77.9	94.8
<b>Remote trip head isolating switches DX<sup>3</sup> 100/125A - 1.5 mod/pole</b>	73				80.1	106.8	61	96	47	79	104.3
<b>DX<sup>3</sup> RCCBs</b>	71.7			35.6		71.2	61	83	44	77.8	94.8
<b>1P DX<sup>3</sup> RCBOs (up to 45A)</b>	68	17.7					60	115	48	74	126.8
<b>1P+N DX<sup>3</sup> RCBOs (up to 40A) &amp; 4P (up to 32A)</b>	71.7		35.6			71.2	61	83	44	77.8	94.8
<b>2P &amp; 4P DX<sup>3</sup> RCBOs (40A to 63A)</b>	72			71.2		124.6	61	96	44	78.2	107.8
<b>1P+N DX<sup>3</sup> MCBs 1 mod</b>	71.7		17.8				61	83	44	77.8	94.8
<b>DX<sup>3</sup> MCBs - 1 mod/pole</b>	71.7	17.7	35.4	35.4	53.1	70.8	61	83	44	77.8	94.8
<b>DX<sup>3</sup> MCBs - 1,5 mod/pole</b>	73.1	26.7		53.4	80.1	106.8	61	100	47	79	104.3
<b>DX<sup>3</sup> add-on modules up to 63A - 1 mod/pole</b>	72			35.6	53.4	53.4	61	96	44	78.2	107.8
<b>DX<sup>3</sup> add-on modules up to 63A - 1.5 mod/pole</b>	72			35.6	53.4	53.4	61	96	47	78.2	116.7
<b>DX<sup>3</sup> add-on modules 80 to 125A - 1.5 mod/pole</b>	72			71.2	106.8	106.8	61	114	47	78.2	129
<b>DX<sup>3</sup> auxiliaries</b>	71.5		8.8 / 17.7				61	83	44	77.7	84.5
<b>DX<sup>3</sup> remote control</b>	74.3		17.7 / 35.4				61	83	44	80.5	98.8
<b>DX<sup>3</sup> Stop&amp;Go automatic resetting</b>	74.3		35.4				61	83	44	80.5	113.7
<b>Change-over switches</b>	68	17.7		35.6			60	83	44	74	94
<b>CX<sup>3</sup> latching relays</b>	64	17.8		17.8	35.6	35.6	61	84.5	44	70.2	94.8
<b>CX<sup>3</sup> contactors up to 25A</b>	66.3/ 61	17.8		17.8	35.6	35.6	61	84.5	44	72.6/ 67.3	94.8
<b>CX<sup>3</sup> contactors 40A &amp; 63A</b>	62			35.6	53.4	53.4	60	83	44	68	94
<b>Auxiliaries for CX<sup>3</sup> contactors and latching relays</b>	61		9/17.8				61	84.5	44	67	84.5
<b>Push-buttons / control switches</b>	68		17.7				60	83	44	74	94
<b>Indicators</b>	68		17.7				60	83	44	69	94
<b>Bells and buzzers</b>	60		17.7				60	76	44	66	85
<b>Light sensitive switches</b>											
<b>Cat.Nos 0 037 21, 4 126 23</b>	60		35.6				60	85	37.5	66	70
<b>Socket outlets</b>	60		44.5				60	83	44	66	92
<b>Time delay relays</b>	60		17.7				60	83	44	66	94
<b>Remote control dimmers</b>											
<b>Cat.No 0 036 58</b>	60		36				60	83	44	66	94
<b>Cat.No 0 036 60</b>	60		72				60	83	44	66	94
<b>Cat.No 0 036 71</b>	60		108				60	83	44	66	94

Description	A	B	C	D	E	F
<b>Programmable time switches</b>						
<b>0 037 05</b>	60	17.8	60	83	44	66
<b>4 127 80/90/94</b>	60	17.8	60	83	44	66
<b>4 127 95, 4 128 12/13</b>	60	53	60	83	44	66
<b>4 126 31/33/41</b>	60	35.6	60	83	44	66
<b>4 126 54/57</b>	60	35.6	60	83	44	66
<b>0 047 70</b>	60	90	60	83	44	66
<b>Transformers and power supplies</b>						
<b>0 042 10/30/31</b>	60	72	60	83	44	66
<b>4 130 91</b>	60	35.8	60	83.5	44	66
<b>4 130 92/93/96</b>	60	71.5	60	83.5	44	66
<b>4 130 98</b>	60	89	60	94	44	66
<b>0 047 91/92</b>	60	105	60	95	44	66
<b>4 131 05/06/07/08</b>	60	89	60	95	44	66
<b>0 047 93</b>	60	70	60	95	44	66
<b>Residual current relay</b>						
<b>0 260 88</b>	60	35.5	60	89	44	66

## Power contactors 40 A and 63 A with or without handle

Cat. N°(s) : 412 506, 507, 511, 512, 515, 516, 518,  
519, 525 to 528, 530, 531, 537 to 542, 545 to 550,  
552 to 557, 559, 560, 562, 563

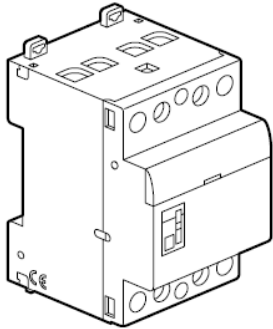

### SOMMAIRE

### PAGES

1. Description, use.....	1
2. Range .....	1
3. Overall dimensions .....	1
4. Preparation - Connection.....	2
5. General characteristics .....	3
6. Conformities and approvals .....	7
7. Auxiliaries .....	7

### 1. DESCRIPTION - USE

#### Symbol :

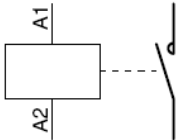

#### Technology :

. Electromagnetic contactor

#### Use :

. remote control of a load by the mean of a switch

### 2. RANGE

#### Rated thermal current :

. I<sub>th</sub> = 40 and 63 A

#### Types of contacts :

. « NO », normally open contact

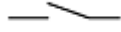

. « NC », normally closed contact



#### Poles :

. Double pole in 2 module (2 x 17,8 mm = 35,6 mm)

- « 2NO »

- « 2NC »

. Four pole in 3 modules (3 x 17,8 mm = 53,4 mm)

- « 3NO »

- « 4NO »

- « 4NC »

- « 3NO + 1NC »

#### Rated voltage (power contacts) :

. U<sub>n</sub> = 250 V / 400 V ~

#### Rated control voltage :

. 24 V and 230 V ~

#### Rated frequency, power and control :

. 50 / 60 Hz

### 3. OVERALL DIMENSIONS

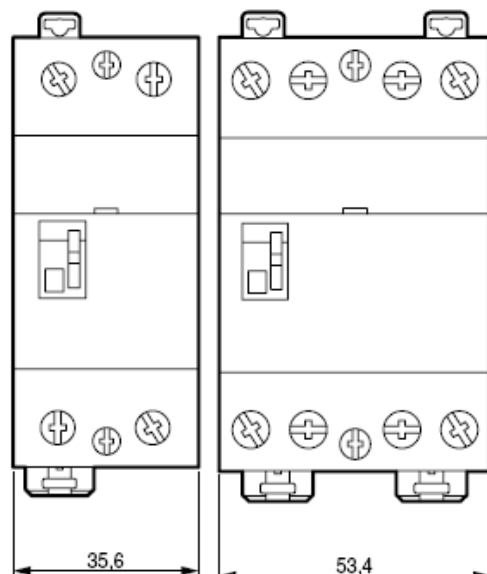
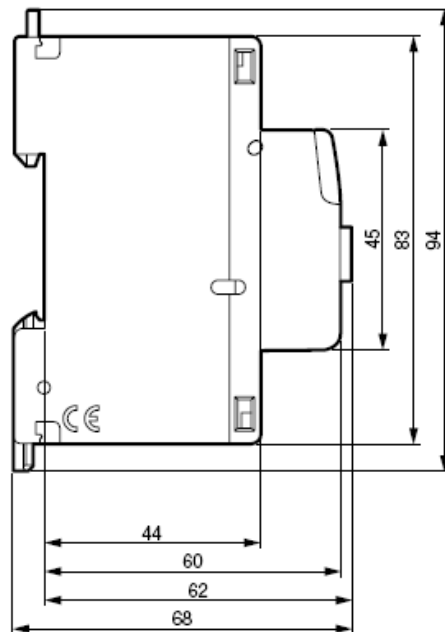

# Power contactors 40 A and 63 A with or without handle

Cat. N°(s) : 412 506, 507, 511, 512, 515, 516, 518,  
519, 525 to 528, 530, 531, 537 to 542, 545 to 550,  
552 to 557, 559, 560, 562, 563

## 4. PREPARATION - CONNECTION

### Installation software :

. XL PRO

### Operational positions :

. Vertical, horizontal, upside down, on the side

### Fixing :

. On symmetrical rail EN 50-055 or DIN 35 by the mean of two plastic clamps.

### Recommended tools :

. For control terminal screws : screwdriver, insulated or not, Pozidriv n°1 or plate (4mm wide).

. For power terminal screws : screwdriver, insulated or not, Pozidriv n°2 or plate (6.5mm wide).

. For fixing : Pozidriv n°1 or plate (5.5 mm max) screwdriver

### Examples of wiring diagrams :

. Contactor « 2 NO »

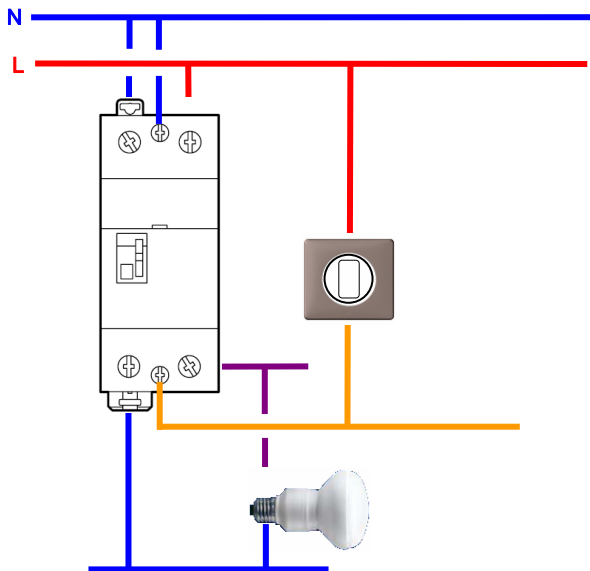

## 4. PREPARATION - CONNECTION *(continued)*

. Contactor « 3 NO »

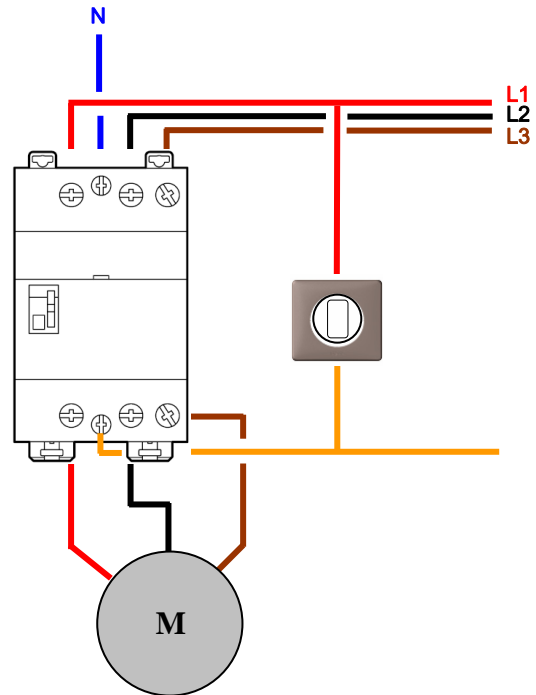

. Contactor « 4 NO »

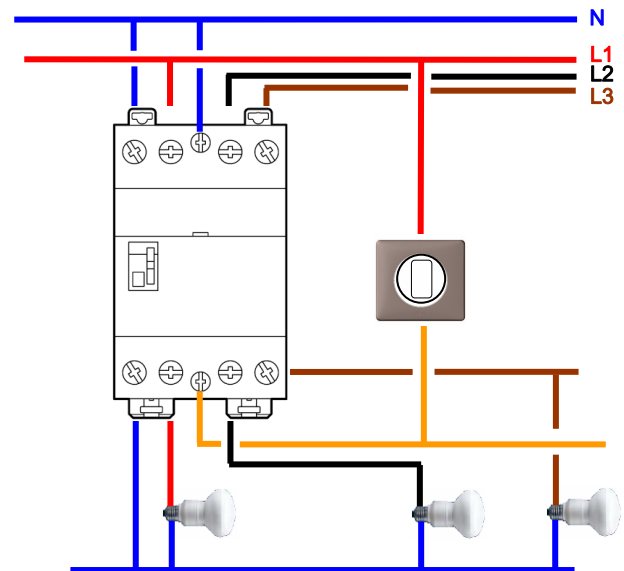

## Power contactors 40 A and 63 A with or without handle

Cat. N°(s) : 412 506, 507, 511, 512, 515, 516, 518, 519,  
525 to 528, 530, 531, 537 to 542, 545 to 550, 552 to 557,  
559, 560, 562, 563

### 4. PREPARATION - CONNECTION *(continued)*

#### Connection :

- Control screw terminals :
  - Type of terminal : cage terminals
  - Terminal depth : 12 mm
  - Terminal capacity (h x w) : 4.7 x 4.7 mm
  - Copper cables
- Rigid : 1 x (0.75 to 6 mm<sup>2</sup>) or 2 x (0.75 to 2.5 mm<sup>2</sup>)
- Flexible without ferrule : 1 x (0.75 to 6 mm<sup>2</sup>) or 2 x (0.75 to 2.5 mm<sup>2</sup>)
- Flexible with single ferrule : 1 x (0.75 to 6 mm<sup>2</sup>)
- Flexible with double ferrule : 1 x (0.75 to 4 mm<sup>2</sup>)
  - Screw head type: mixed, Posidriv n° 1 and slotted 4 mm
  - Type of screw : M3
  - Tightening torque : mini = 0.5 Nm / max = 1.2 Nm / recommended = 0.8 Nm
- Power screw terminals :
  - Type of terminal : cage terminals
  - Terminal depth : 14 mm
  - Copper cables
- Rigid : 1 x (0.75 to 25 mm<sup>2</sup>) or 2 x (0.75 to 10 mm<sup>2</sup>)
- Flexible without ferrule : 1 x (0.75 to 25 mm<sup>2</sup>) or 2 x (0.75 to 10 mm<sup>2</sup>)
- Flexible with single ferrule : 1 x (0.75 to 16 mm<sup>2</sup>)
- Flexible with double ferrule : 1 x (0.75 to 16 mm<sup>2</sup>)
  - Screw head type: mixed, Posidriv n° 2 and slotted 6.5 mm
  - Type of screw : M5
  - Tightening torque : mini = 1.3 Nm / max = 3.5 Nm / recommended = 2.5 Nm

#### Length of control lines :

- 24 V contactor : 100 m with 1.5 mm<sup>2</sup> copper wire
- 230 V contactor : 300 m whatever the wire cross-section.

#### Protection degree :

- Terminal ingress protection : IP2x (device connected)
- Front face ingress protection : IP3XD
- Classe II, front face behind a cabinet faceplate
- Protection against mechanical shocks : IK04

#### Shaking resistance :

- No change of contact state during shaking test in accordance with EN 60898 standard

#### actuation :

- By electric remote control (switch)
- By ergonomic 3 position (I, auto, O) handle when contactor is equipped with

#### Display of contacts state :

- By orange indicator when manual or electric control is on
- When contactor is fitted with a handle,
  - Position « I » : permanent control ON
  - Position « O » : permanent control OFF
  - Position « auto » : electric control by switch

#### Labelling :

- Circuit may be labelled by the mean of the label holder on the front face of the latching relay

### 5. GENERAL CHARACTERISTICS

#### Marking :

By permanent ink pad printing :

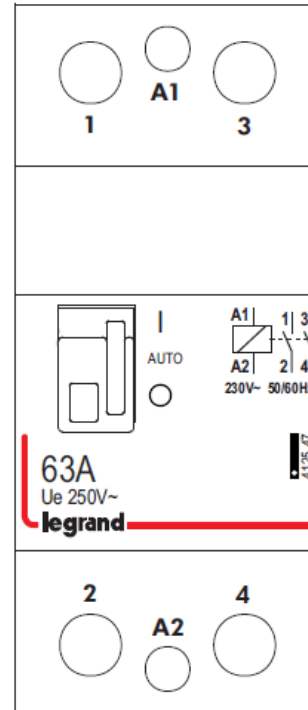

#### Isolation :

- > 3 mm in compliance with EN 61095 standard

#### Isolation rated voltage (Ui) :

- Double pole : 250 V~
- Triple pole / Four pole : 400 V~

#### Pollution degree :

- 2 according to EN 61095 standard

#### Isolation voltage between control and load :

- 4 000 V.

#### Rated impulse withstand voltage (Uimp) :

- 4 kV

#### Distance de sectionnement :

- Supérieure à 3 mm selon norme EN 61095

#### Tension assignée d'isolement (Ui) :

- Bipolaire : 250 V~
- Tri / Tétrapolaire : 400 V~

#### Degré de pollution :

- 2 selon EN 61095

#### Tension d'isolement entre le circuit de commande et le circuit de puissance :

- 4 kV

# Power contactors 40 A and 63 A with or without handle

Cat. N°(s) : 412 506, 507, 511, 512, 515, 516, 518, 519,  
525 to 528, 530, 531, 537 to 542, 545 to 550, 552 to 557,  
559, 560, 562, 563

## 5. GENERAL CHARACTERISTICS (continued)

### Withstand to electromagnetic disturbances (EMC) :

. Schock wave 1,2 / 50  $\mu$ s : class 4 (2 kV between lines, 4 kV between line and earth)

### Influence of altitude :

. no effect up to 2 000 m

### Rated frequency :

. 50 / 60 Hz

### Rated current for each category of use (Ie) :

Type of contact	AC1 / AC7a heating		AC3 / AC7b motors	
	Ie	P	Ie	P
2NO / 2NC	40 A	9 kW	22 A	5.5 kW
3NO / 4NO / 3NO+1NC / 4 NC	40 A	26 kW	22 A	11 kW
2NO / 2NC	63 A	14 kW	30 A	8 kW
3NO / 4NO / 3NO+1NC / 4 NC	63 A	40 kW	30 A	15 kW

### Operation rated voltage (Ue) :

. Ue = 250 V ~ for double pole

. Ue = 400 V ~ for triple pole and four pole

### Protection against short-circuits :

. Conditionnal short-circuit current Iq = 3 000 A according to EN 61095 standard

. Maximum thermal stress : 18 000 A<sup>2</sup>s

. To protect 40 A and 63 A contactors against short-circuits in accordance with conditionnal current Iq = 3 000 A (EN 61095 standard), we recommend to use a  $\leq$  40 A rated current M.C.B. or gG fuse for a 40 A contactor and a  $\leq$  63 A rated current M.C.B. or gG fuse for a 63A contactor

### Control voltage (Uc) :

. Uc = 230 V~ or 24 V~

### Operating control voltage :

. from 0.85 to 1.1 Uc

### Release control voltage :

. from 0.2 to 0.75 Uc

### Control impulse time :

. 100 ms mini

### Rated duty :

. Intermittent duty : 600 operating cycles per hour according to EN 61095 standard (class 600)

### Force by handle operation :

. 500 g for closing and opening operation

### Operation under 400 Hz :

. not possible

## 5. GENERAL CHARACTERISTICS (continued)

### Endurance :

In number of operating cycles (ON + OFF)

. Control by handle : 1000 operating cycles

. Electrical control :

- 1 000 000 operating cycles with no load
- 100 000 operating cycles at Ie AC-7a in accordance with EN 61095 (same at Ie AC1)
- 30 000 operating cycles at Ie AC-7b in accordance with EN 61095 (same at Ie AC3)

### Use with Direct Current (DC) :

. Control : do not operate with DC

. Power circuit : NO and NC contacts may be used to control loads supplied with DC in accordance with the table of max current below for 63 A contactors

Ue	DC 1 (resistiv load)			DC 3 (motors)		
	number of poles in series			number of poles in series		
	1 p	2 p	3 p	1 p	2 p	3 p
8 V=	63 A	63 A	63 A	54 A	63 A	63 A
12 V=	63 A	63 A	63 A	50 A	63 A	63 A
24 V=	63 A	63 A	63 A	40 A	63 A	63 A
48 V=	53 A	63 A	63 A	20 A	45 A	63 A
110 V=	18 A	40 A	63 A	4 A	16 A	40 A

### Control consumption :

Type of contact	Control voltage	Current in mA (at Un)	
		sustain	inrush
2NO	24 V~	250	1750
4NO		270	1500
2NO	230 V~	130	150
2NC		130	150
3NO+1NC		30	200
3NO / 4NO / 4NC		30	200

Type of contact	Control voltage	Power in W (at Un)
		sustain
2NO	24 V~	1.8
4NO		1.9
2NO	230 V~	0.9
2NC		0.9
3NO+1NC		2.1
3NO / 4NO / 4NC		2.1

# Power contactors 40 A and 63 A with or without handle

Cat. N°(s) : 412 506, 507, 511, 512, 515, 516, 518, 519,  
525 to 528, 530, 531, 537 to 542, 545 to 550, 552 to 557,  
559, 560, 562, 563

## 5. GENERAL CHARACTERISTICS (continued)

### Average dissipated power per contact at 230V :

- . 1.8 W per contact of 40 A contactor
- . 3.5 W per contact of 63 A contactor

### Annual energy consumption of contactors :

- . Loads supplied in 230/400V 50Hz network
- . Global energy consumption, control + power contacts, with an « average » use.

Type of contact	Control voltage	in kWh (at Un)
2NO	24 V~	3.1
4NO		4.8
2NO	230 V~	2.4
2NC		2.4
3NO		4.1
3NO+1NC		5
4NC		5
4NO		5

### Noise (holding) :

- . Standard contactor  $\leq 50$  dB at 1 cm and  $\leq 30$  dB at 1 m
- . Noiseless contactor  $\leq 32$  dB at 1 cm and  $\leq 20$  dB at 1 m

### Operating temperatures :

- . A standard contactor is set to operate at its rated current (40 A or 63 A) in an ambient temperature of + 30°C
- . In order to limitate overheating, we recommend to use a spacing element (cat. n° 044 40)
  - Every 2 contactors if the ambient temperature  $\leq 40^\circ\text{C}$
  - Every contactors if the ambient temperature  $> 40^\circ\text{C}$
- . Depending on ambient temperature, deratings below must be used :

- from - 25°C to + 40°C, no derating
- from + 40°C to + 60°C derating as in table below

Contacteur rated current	40°C	50°C	60°C
le = 40 A	40 A	36 A	32 A
le = 63 A	63 A	57 A	50 A

### Storage temperature :

- . from - 40°C up to + 70°C

### Moulded case material :

- . Polyamid

### Characteristics of the plastic material :

- . Resistance to glow wire test during 30 s according to IEC 695-2-1:
  - Handle : 650°C
  - Other components : 850°C

### Weight :

- . 0.240 kg per double pole device
- . 0.330 kg per triple pole / four pole device

### Packaged volume :

- . 0.4 dm<sup>3</sup> for double pole individually packaged units
- . 0.6 dm<sup>3</sup> for triple pole and four pole individually packaged units

## 5. GENERAL CHARACTERISTICS (continued)

### Contactors choice table :

For a life time of 10 years with 200 days of annual use

#### . Heating

Maximum power according to the number of operations per day (kW)						
Number of operations per day		$\leq 50$	75	100	250	500
230 V~ single phase heating	40 A	9	7.5	6	4	2.5
	63 A	14	12	9.5	6	4.5
400 V~ three phase heating	40 A	26	22	17	8	6
	63 A	41	35	26	13	9
Floor heating	40 A	2.5				
	63 A	4				

#### . Motors (AC-7b)

Maximum power (kW)		
230 V~ single phase motor	40 A	2.5
	63 A	4
400 V~ three phase motor	40 A	7.5
	63 A	15

#### . Lighting

Maximum number of lamps per contact of the contactor in 230 V~ single phase network and 400 V~ three phase and neutral network.

- . In 230 V~ three phase network with no neutral, values of the table must be divided by  $\sqrt{3}$ .

- Incandescent lamps

Tungsten filament 230 V~ and low voltage halogen				
Unit power	40 W	60 W	75 W	100 W
40 A	96	77	61	48
63 A	154	123	97	77

Tungsten filament 230 V~ and low voltage halogen (continued)				
Unit power	150 W	200 W	500 W	1000 W
40 A	32	24	10	5
63 A	51	38	15	8

Very Low Voltage halogen lamps with ferromagnetic ballast						
Unit power	20 W	35 W	50 W	75 W	100 W	150 W
40 A	68	39	31	21	16	10
63 A	88	51	41	27	20	14

Very Low Voltage halogen lamps with electronic ballast						
Unit power	20 W	35 W	50 W	75 W	100 W	150 W
40 A	112	70	56	36	28	18
63 A	157	98	78	51	39	25



# Power contactors 40 A and 63 A with or without handle

Cat. N°(s) : 412 506, 507, 511, 512, 515, 516, 518, 519,  
525 to 528, 530, 531, 537 to 542, 545 to 550, 552 to 557,  
559, 560, 562, 563

## 5. GENERAL CHARACTERISTICS (continued)

- Fluorescent lamps with ferromagnetic ballast

Single parallel compensated					
Unit power	18 W	20 W	36 W	58 W	115 W
40 A	<b>43</b>	<b>39</b>	<b>33</b>	<b>22</b>	<b>12</b>
63 A	<b>56</b>	<b>51</b>	<b>42</b>	<b>29</b>	<b>15</b>

Twin serial compensated					
Unit power	2 x 20 W	2 x 36 W	2 x 40 W	2 x 58 W	2 x 140
40 A	<b>68</b>	<b>57</b>	<b>53</b>	<b>36</b>	<b>15</b>
63 A	<b>101</b>	<b>86</b>	<b>79</b>	<b>54</b>	<b>23</b>

Four serial compensated	
Unit power	4 x 18 W
40 A	<b>36</b>
63 A	<b>54</b>

Compact with integrated starter				
Unit power	7 W	10 W	18 W	26 W
40 A	<b>78</b>	<b>65</b>	<b>55</b>	<b>36</b>
63 A	<b>101</b>	<b>85</b>	<b>71</b>	<b>47</b>

- Fluorescent lamps with electronic ballast

Single				
Unit power	18 W	30 W	36 W	58 W
40 A	<b>165</b>	<b>102</b>	<b>87</b>	<b>54</b>
63 A	<b>248</b>	<b>153</b>	<b>131</b>	<b>81</b>

Twin			
Unit power	2 x 18 W	2 x 36 W	2 x 58 W
40 A	<b>84</b>	<b>45</b>	<b>29</b>
63 A	<b>126</b>	<b>68</b>	<b>43</b>

Triple serial compensated		
Unit power	3 x 14 W	3 x 18 W
40 A	<b>62</b>	<b>51</b>
63 A	<b>84</b>	<b>69</b>

Four serial compensated		
Unit power	4 x 14 W	4 x 18 W
40 A	<b>52</b>	<b>39</b>
63 A	<b>73</b>	<b>55</b>

With integrated electronic supply					
Unit power	7 W	11 W	15 W	20 W	23 W
40 A	<b>280</b>	<b>175</b>	<b>126</b>	<b>98</b>	<b>84</b>
63 A	<b>392</b>	<b>245</b>	<b>176</b>	<b>137</b>	<b>118</b>

## 5. GENERAL CHARACTERISTICS (continued)

- Discharge lamps with compensator

Metal halide						
Unit power	35 W	70 W	100 W	150 W	250 W	400 W
40 A	<b>23</b>	<b>14</b>	<b>11</b>	<b>8</b>	<b>5</b>	<b>3</b>
63 A	<b>34</b>	<b>20</b>	<b>16</b>	<b>11</b>	<b>7</b>	<b>5</b>

Low pressure sodium						
Unit power	18 W	35 W	55 W	90 W	135 W	180 W
40 A	<b>30</b>	<b>15</b>	<b>11</b>	<b>8</b>	<b>5</b>	<b>5</b>
63 A	<b>45</b>	<b>23</b>	<b>16</b>	<b>11</b>	<b>7</b>	<b>7</b>

High pressure sodium					
Unit power	70 W	150 W	250 W	400 W	1000 W
40 A	<b>15</b>	<b>14</b>	<b>9</b>	<b>6</b>	<b>3</b>
63 A	<b>23</b>	<b>20</b>	<b>14</b>	<b>9</b>	<b>5</b>

High pressure mercury					
Unit power	50 W	80 W	125 W	250 W	400 W
40 A	<b>21</b>	<b>14</b>	<b>11</b>	<b>6</b>	<b>4</b>
63 A	<b>29</b>	<b>20</b>	<b>16</b>	<b>8</b>	<b>6</b>

Mixed high pressure				
Unit power	100 W	160 W	250 W	400 W
40 A	<b>14</b>	<b>9</b>	<b>7</b>	<b>4</b>
63 A	<b>19</b>	<b>12</b>	<b>8</b>	<b>5</b>

- Led lamps

Led lamps number without driver or not dimmable										
In (A)	2W	5W	7W	9W	12 W	18 W	22 W	30 W	40 W	50 W
40A	<b>90</b>	<b>90</b>	<b>85</b>	<b>85</b>	<b>85</b>	<b>80</b>	<b>75</b>	<b>62</b>	<b>50</b>	<b>37</b>
63A	<b>150</b>	<b>150</b>	<b>140</b>	<b>140</b>	<b>140</b>	<b>115</b>	<b>100</b>	<b>80</b>	<b>70</b>	<b>55</b>

Led lamps number with driver or dimmable										
In (A)	2W	5W	7W	9W	12 W	18 W	22 W	30 W	40 W	50 W
40A	<b>170</b>	<b>170</b>	<b>170</b>	<b>162</b>	<b>162</b>	<b>129</b>	<b>113</b>	<b>95</b>	<b>77</b>	<b>65</b>
63A	<b>265</b>	<b>265</b>	<b>265</b>	<b>260</b>	<b>260</b>	<b>214</b>	<b>176</b>	<b>139</b>	<b>121</b>	<b>105</b>

## Power contactors 40 A and 63 A with or without handle

Cat. N°(s) : 412 506, 507, 511, 512, 515, 516, 518, 519,  
525 to 528, 530, 531, 537 to 542, 545 to 550, 552 to 557,  
559, 560, 562, 563

### 6. CONFORMITIES AND APPROVALS

**Compliance :**

. EN 61095 / NFC 61-480 – IEC 61095

**Certificates :**

- . NF (France)
- . VDE (Germany)
- . GOST (Russia)

**Tropicalization :**

. execution 2 (all climates) according to U.T.E. C 63-100 guide

**Environment :**

- . complying with RoHS
- . without halogen

### 7. AUXILIARIES

**Auxiliaries :**

- . Signalling change-over switch NO+NC auxiliary cat. n° 412431.
- . Used to indicate the position status of the contacts of the product with which it is associated.

**Association of the auxiliaries :**

- . Auxiliaries are fitted on left hand side of contactor
- . Maximum of 1 change-over switch auxiliary per contactor