

MPCBs MPX³

motor protection circuit breakers from 0.16 A to 100 A



4 173 08

4 173 68

4 173 79

4 173 48

Technical characteristics [see e-catalogue](#)

Conform to IEC 60947-1, IEC 60947-2, IEC 60947-4 ; class 10

Pack	Cat. Nos	Thermal magnetic MPCBs			
		Adjustable thermal release Magnetic release 13 le max.			
		MPX³ 32S			
		Standard breaking capacity With toggle handle Fixing on rail			
		3-phase motor 400/415 V (kW)	Thermal release adjustment range (A)	Magnetic release operating current (A)	415 V breaking capacity Icu (kA)
	3P				
1	4 173 00	0.02	0.1 to 0.16	2.1	100
1	4 173 01	0.06	0.16 to 0.25	3.3	100
1	4 173 02	0.09	0.25 to 0.4	5.2	100
1	4 173 03	0.12	0.4 to 0.63	8.2	100
1	4 173 04	0.18/0.25	0.63 to 1	13	100
1	4 173 05	0.37/0.55	1 to 1.6	20.8	100
1	4 173 06	0.75	1.6 to 2.5	32.5	100
1	4 173 07	1.5	2.5 to 4	52	100
1	4 173 08	2.2	4 to 6	78	100
1	4 173 09	3	5 to 8	104	100
1	4 173 10	4	6 to 10	130	50
1	4 173 11	5.5	9 to 13	169	50
1	4 173 12	7.5	11 to 17	221	20
1	4 173 13	7.5	14 to 22	286	15
1	4 173 14	11	18 to 26	338	15
1	4 173 15	15	22 to 32	416	15
		MPX³ 32H			
		High breaking capacity With rotary handle Fixing on rail			
1	4 173 20	0.02	0.1 to 0.16	2.1	100
1	4 173 21	0.06	0.16 to 0.25	3.3	100
1	4 173 22	0.09	0.25 to 0.4	5.2	100
1	4 173 23	0.12	0.4 to 0.63	8.2	100
1	4 173 24	0.18/0.25	0.63 to 1	13	100
1	4 173 25	0.37/0.55	1 to 1.6	20.8	100
1	4 173 26	0.75	1.6 to 2.5	32.5	100
1	4 173 27	1.5	2.5 to 4	52	100
1	4 173 28	2.2	4 to 6	78	100
1	4 173 29	3	5 to 8	104	100
1	4 173 30	4	6 to 10	130	100
1	4 173 31	5.5	9 to 13	169	100
1	4 173 32	7.5	11 to 17	221	50
1	4 173 33	7.5	14 to 22	286	50
1	4 173 34	11	18 to 26	338	50
1	4 173 35	15	22 to 32	416	50
		MPX³ 63H			
		High breaking capacity With rotary handle Fixing on rail or by screw			
1	4 173 60	4	6 to 10	130	100
1	4 173 61	5.5	9 to 13	169	100
1	4 173 62	7.5	11 to 17	221	50
1	4 173 63	7.5	14 to 22	286	50
1	4 173 64	11	18 to 26	338	50
1	4 173 65	15	22 to 32	416	50
1	4 173 66	18.5	28 to 40	520	50
1	4 173 67	22	34 to 50	650	50
1	4 173 68	30	45 to 63	819	50





Pack	Cat. Nos	Thermal magnetic MPCBs (continued)			
		MPX³ 100H			
		High breaking capacity With rotary handle Fixing on rail or by screw			
		3-phase motor 400/415 V (kW)	Thermal release adjustment range (A)	Magnetic release operating current (A)	415 V breaking capacity Icu (kA)
	3P				
1	4 173 70	7.5	11 to 17	221	100
1	4 173 71	7.5	14 to 22	286	100
1	4 173 72	11	18 to 26	338	100
1	4 173 73	15	22 to 32	416	100
1	4 173 74	18.5	28 to 40	520	100
1	4 173 75	22	34 to 50	650	100
1	4 173 76	30	45 to 63	819	100
1	4 173 77	37	55 to 75	975	75
1	4 173 78	45	70 to 90	1170	75
1	4 173 79	45	80 to 100	1300	75
		Magnetic only MPCBs			
		Without thermal release Magnetic release 13 x le max.			
		MPX³ 32MA			
		High breaking capacity With rotary handle Fixing on rail			
		3-phase motor 400/415 V (kW)	Magnetic release operating current (A)	415 V breaking capacity Icu (kA)	
	3P				
1	4 173 40	0.02	2.1	100	
1	4 173 41	0.06	3.3	100	
1	4 173 42	0.09	5.2	100	
1	4 173 43	0.12	8.2	100	
1	4 173 44	0.18/0.25	13	100	
1	4 173 45	0.37/0.55	20.8	100	
1	4 173 46	0.75	32.5	100	
1	4 173 47	1.5	52	100	
1	4 173 48	2.2	78	100	
1	4 173 49	3	104	100	
1	4 173 50	4	130	100	
1	4 173 51	5.5	169	100	
1	4 173 52	7.5	221	50	
1	4 173 53	7.5	286	50	
1	4 173 54	11	338	50	
1	4 173 55	15	416	50	

For dimensions and wiring capacity
[see e-catalogue](#)



MPCBs MPX³

technical characteristics

																																
MPCB	MPX³ 32S	MPX³ 32H		MPX³ 32MA	MPX³ 63H	MPX³ 100H																										
Size	1	2		2	3	4																										
Type	Thermal magnetic	Thermal magnetic		Magnetic only	Thermal magnetic	Thermal magnetic																										
Breaking capacity	Standard	High		High	High	High																										
Handle type	Toggle	Rotary		Rotary	Rotary	Rotary																										
Number of poles	3	3		3	3	3																										
Characteristics of use																																
Rated operational voltage (Ue)	Up to 690 V			Up to 690 V		Up to 690 V																										
Rated frequency	50/60 Hz			50/60 Hz		50/60 Hz																										
Rated insulation voltage (Ui)	690 V			690 V		1000 V																										
Rated impulse voltage (Uimp)	6 kV			6 kV		8 kV																										
Utilisation category	Cat. A			Cat. A		Cat. A																										
IEC 60947-2 (breaker)	AC3			AC3		AC3																										
IEC 60947-4 (Motor starter)	100000			100000		50000																										
Mechanical endurance (Operating)	100000			100000		25000																										
Electric endurance (Cycles)	25			25		25																										
Max operating frequency per hour (Ope./h)	-20 to +60°C			-20 to +60°C		-20 to +60°C																										
Temperature compensation	13 x Ie max.			13 x Ie max.		13 x Ie max.																										
Instantaneous short circuit release	10			0		10																										
Trip class	•			-		•																										
Overload protection	•			-		•																										
Phase failure protection	•			-		•																										
Trip indicating function	with alarm contact 4 174 06/07			with alarm contact 4 174 06/07		with alarm contact 4 174 06/07																										
Test function	•			•		•																										
Weight (g)	320			360		1000																										
Rated breaking capacity (kA)	240V 230V 220V		415V 400V		460V 440V		525V 500V		690V 600V		240V 230V 220V		415V 400V		460V 440V		525V 500V		690V 600V		240V 230V 220V		415V 400V		460V 440V		525V 500V		690V 600V			
Rated operational current Ie (A)	Thermal release adjustment range (A)	Icu	Ics	Icu	Ics	Icu	Ics	Icu	Ics	Icu	Ics	Icu	Ics	Icu	Ics	Icu	Ics	Icu	Ics	Icu	Ics	Icu	Ics	Icu	Ics	Icu	Ics	Icu	Ics	Icu	Ics	
0.16	0.1 to 0.16	100	100	100	100	100	100	100	100	100	100	100	100	100	100	100	100	100	100	100	100	100	100	100	100	100	100	100	100	100	100	100
0.25	0.16 to 0.25	100	100	100	100	100	100	100	100	100	100	100	100	100	100	100	100	100	100	100	100	100	100	100	100	100	100	100	100	100	100	100
0.4	0.25 to 0.4	100	100	100	100	100	100	100	100	100	100	100	100	100	100	100	100	100	100	100	100	100	100	100	100	100	100	100	100	100	100	100
0.63	0.4 to 0.63	100	100	100	100	100	100	100	100	100	100	100	100	100	100	100	100	100	100	100	100	100	100	100	100	100	100	100	100	100	100	100
1	0.63 to 1	100	100	100	100	100	100	100	100	100	100	100	100	100	100	100	100	100	100	100	100	100	100	100	100	100	100	100	100	100	100	100
1.6	1 to 1.6	100	100	100	100	100	100	100	100	3	3	100	100	100	100	100	100	100	100	100	100	100	100	100	100	100	100	100	100	100	100	100
2.5	1.6 to 2.5	100	100	100	100	100	100	100	100	50	38	3	3	100	100	100	100	100	100	100	100	100	100	100	100	100	100	100	100	100	100	100
4	2.5 to 4	100	100	100	100	100	100	100	100	50	38	15	11	3	3	100	100	100	100	100	100	100	100	100	100	100	100	100	100	100	100	100
6	4 to 6	100	100	100	100	100	100	15	11	10	8	3	3	100	100	100	100	100	100	100	100	100	100	100	100	100	100	100	100	100	100	100
8	5 to 8	100	100	100	100	15	11	10	8	3	3	100	100	100	100	50	38	50	38	6	6	100	100	100	100	100	100	100	100	100	100	100
10	6 to 10	100	100	50	38	15	11	6	5	3	3	100	100	100	100	50	38	50	38	6	6	100	100	100	100	100	100	100	100	100	100	100
13	9 to 13	100	100	50	38	10	8	6	5	3	3	100	100	100	100	50	38	42	32	6	6	100	100	100	100	100	100	100	100	100	100	100
17	11 to 17	50	38	20	15	10	8	6	5	3	3	100	100	50	38	20	15	10	8	4	4	100	100	50	38	20	15	10	8	4	4	100
22	14 to 22	40	30	15	11	8	6	6	5	3	3	100	100	50	38	20	15	10	8	4	4	100	100	50	38	20	15	10	8	4	4	100
26	18 to 26	40	30	15	11	8	6	5	4	3	3	100	100	50	38	20	15	10	8	4	4	100	100	50	38	20	15	10	8	4	4	100
32	22 to 32	30	22	15	11	6	4	5	4	3	3	100	100	50	38	20	15	10	8	4	4	100	100	50	38	20	15	10	8	4	4	100
40	28 to 40	-	-	-	-	-	-	-	-	-	-	-	-	-	-	-	-	-	-	-	-	100	100	50	38	20	15	10	8	4	4	100
50	34 to 50	-	-	-	-	-	-	-	-	-	-	-	-	-	-	-	-	-	-	-	-	100	100	50	38	20	15	10	8	4	4	100
63	45 to 63	-	-	-	-	-	-	-	-	-	-	-	-	-	-	-	-	-	-	-	-	100	100	50	38	20	15	10	8	4	4	100
75	55 to 75	-	-	-	-	-	-	-	-	-	-	-	-	-	-	-	-	-	-	-	-	100	100	75	50	50	38	12	9	6	6	100
90	70 to 90	-	-	-	-	-	-	-	-	-	-	-	-	-	-	-	-	-	-	-	-	100	100	75	50	50	38	12	9	6	6	100
100	80 to 100	-	-	-	-	-	-	-	-	-	-	-	-	-	-	-	-	-	-	-	-	100	100	75	50	50	38	12	9	6	6	100

MPCBs MPX³

technical characteristics

Mounting

MPX³ 32: 35 mm rail (depth 15 mm)
 MPX³ 63: 35 mm rail (depth 15 mm) or screws
 MPX³ 100: 35 mm (depth 15 mm) or 75 mm rail or screws

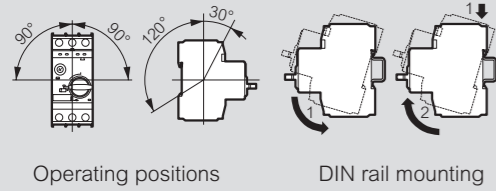

Caution for thermal adjustments

1. Keep the setting range as shown below
2. Moving counterclockwise out of the setting range may cause the damage of the device

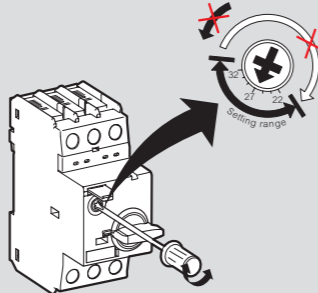

Dial setting method

3. Calibration by ambient air temperature

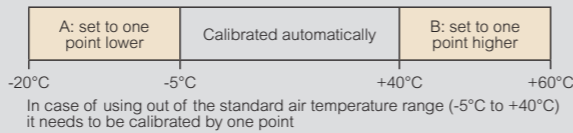

Environment

Ambient air temperature:
 - storage: -50...+80°C
 - operation: -20...+60°C
 Ambient temperature compensation: -20...+60°C
 Maximum operating altitude: 2000 m
 Protection degree: IP20
 Shock resistance: 25 g
 Vibration resistance: 5~150 Hz

Power consumption

	MPX ³ 32S	MPX ³ 32H/MA	MPX ³ 63H	MPX ³ 100H
Total power loss P _v	In = 0.16 to 1.6 A: 4.4	In = 0.16 to 1.6 A: 4.4	In = 10 to 22 A: 10.2	In = 17 to 32 A : 15
Circuit breaker at rated load operating temperature (W)	In = 2.5 to 26 A : 7.4 In = 32 A : 4.0	In = 2.5 to 26 A : 7.4 In = 32 A : 4.0	In = 26 to 63 A: 9.7	In = 40 to 63 A : 21.8 In = 75 to 100 A: 17.8

MPX³ 32S

Rated operational current I _e (A)	0.16	0.25	0.4	0.63	1	1.6	2.5	4	6	8	10	13	17	22	26	32
Switching of standard three-phase motors AC-2, AC-3																
230/240V (kW)	-	0.03	0.06	0.09	0.12	0.18/0.25	0.37	0.55/0.75	1.1/1.5	1.5	2.2/3	3	3.7/4	4	5.5	7.5
400/415V (kW)	0.02	0.06	0.09	0.12	0.18/0.25	0.37/0.55	0.75	1.1/1.5	2.2	3	3.7/4	5.5	7.5	7.5	11	15
500V (kW)	-	-	-	0.25	0.37	0.55/0.75	1.1	1.5/2.2	3	3.7	4/5.5	7.5	11	11	15	18.5
690V (kW)	-	-	-	0.25	0.37/0.55	0.75/1.1	1.5	2.2/3	3.7/4	5.5	7.5	11	11	15	18.5	22
Back-up fuses gG, gL, only if I _{cc} > I _{cu} (* = no back up fuse required)																
230/240V (A)	*	*	*	*	*	*	*	*	*	*	*	*	*	125	125	125
400/415V (A)	*	*	*	*	*	*	*	*	*	*	80	80	100	100	100	
440/460V (A)	*	*	*	*	*	*	*	50	50	63	63	80	80	100	100	
500V (A)	*	*	*	*	*	*	*	40	50	63	63	80	80	80	80	
690V (A)	*	*	*	*	*	20	35	40	50	63	63	63	63	63	63	

MPX³ 32H

Rated operational current I _e (A)	0.16	0.25	0.4	0.63	1	1.6	2.5	4	6	8	10	13	17	22	26	32
Switching of standard three-phase motors AC-2, AC-3																
230/240V (kW)	-	0.03	0.06	0.09	0.12	0.18/0.25	0.37	0.55/0.75	1.1/1.5	1.5	2.2/3	3	3.7/4	4	5.5	7.5
400/415V (kW)	0.02	0.06	0.09	0.12	0.18/0.25	0.37/0.55	0.75	1.1/1.5	2.2	3	3.7/4	5.5	7.5	7.5	11	15
500V (kW)	-	-	-	0.25	0.37	0.55/0.75	1.1	1.5/2.2	3	3.7	4/5.5	7.5	11	11	15	18.5
690V (kW)	-	-	-	0.25	0.37/0.55	0.75/1.1	1.5	2.2/3	3.7/4	5.5	7.5	11	11	15	18.5	22
Back-up fuses gG, gL, only if I _{cc} > I _{cu} (* = no back up fuse required)																
230/240V (A)	*	*	*	*	*	*	*	*	*	*	*	*	*	*	*	*
400/415V (A)	*	*	*	*	*	*	*	*	*	*	*	100	125	125	125	
440/460V (A)	*	*	*	*	*	*	*	*	80	80	80	80	100	100	100	
500V (A)	*	*	*	*	*	*	*	*	63	80	80	80	80	80	80	
690V (A)	*	*	*	*	*	*	35	40	50	63	63	63	63	63	63	

MPX³ 32MA

Rated operational current I _e (A)	0.16	0.25	0.4	0.63	1	1.6	2.5	4	6	8	10	13	17	22	26	32
AC-2, AC-3																
230/240V (kW)	-	0.03	0.06	0.09	0.12	0.18/0.25	0.37	0.55/0.75	1.1/1.5	1.5	2.2/3	3	3.7/4	4	5.5	7.5
400/415V (kW)	0.02	0.06	0.09	0.12	0.18/0.25	0.37/0.55	0.75	1.1/1.5	2.2	3	3.7/4	5.5	7.5	7.5	11	15
500V (kW)	-	-	-	0.25	0.37	0.55/0.75	1.1	1.5/2.2	3	3.7	4/5.5	7.5	11	11	15	18.5
690V (kW)	-	-	-	0.25	0.37/0.55	0.75/1.1	1.5	2.2/3	3.7/4	5.5	7.5	11	11	15	18.5	22
Back-up fuses gG, gL, only if I _{cc} > I _{cu} (* = no back up fuse required)																
230/240V (A)	*	*	*	*	*	*	*	*	*	*	*	*	*	*	*	*
400/415V (A)	*	*	*	*	*	*	*	*	*	*	*	*	100	125	125	
440/460V (A)	*	*	*	*	*	*	*	*	80	80	80	80	80	100	100	
500V (A)	*	*	*	*	*	*	*	*	63	80	80	80	80	80	80	
690V (A)	*	*	*	*	*	*	35	40	50	63	63	63	63	63	63	

MPX³ 63H

Rated operational current I _e (A)	10	13	17	22	26	32	40	50	63
Switching of standard three-phase motors AC-2, AC-3									
230/240V (kW)	2.2/3	3	3.7/4	4	5.5	7.5	7.5	11	15
400/415V (kW)	3.7/4	5.5	7.5	7.5	11	15	18.5	22	30
500V (kW)	4/5.5	7.5	11	11	15	18.5	22	30	37
690V (kW)	7.5	11	11	15	18.5	22	30	45	55
Back-up fuses gG, gL, only if I _{cc} > I _{cu} (* = no back up fuse required)									
230/240V (A)	*	*	*	*	*	*	*	*	*
400/415V (A)	*	*	100	125	125	125	160	160	160
440/460V (A)	100	100	100	125	125	125	125	125	160
500V (A)	100	100	100	100	100	100	100	100	100
690V (A)	63	63	63	80	80	80	80	80	80

MPX³ 100H

Rated operational current I _e (A)	17	22	26	32	40	50	63	75	90	100
Switching of standard three-phase motors AC-2, AC-3										
230/240V (kW)	3.7/4	4	5.5	7.5	7.5	11	15	22	30	30
400/415V (kW)	7.5	7.5	11	15	18.5	22	30	37	45	45
500V (kW)	11	11	15	18.5	22	30	37	45	55	63
690V (kW)	11	15	18.5	22	30	45	55	63	75	90
Back-up fuses gG, gL, only if I _{cc} > I _{cu} (* = no back up fuse required)										
230/240V (A)	*	*	*	*	*	*	*	*	*	*
400/415V (A)	*	*	*	*	*	*	*	*	*	*
440/460V (A)	125	125	125	160	160	160	200	200	200	200
500V (A)	100	125	125	125	160	160	160	160	160	160
690V (A)	80	80	80	80	80	100	100	125	160	160

Number of auxiliaries per circuit breaker

Auxiliaries	MPX ³ 32S	MPX ³ 32H/MA	MPX ³ 63H	MPX ³ 100H
Auxiliary contact front mounting	1	1	1	1
Auxiliary contact side mounting	1	1	1	1
Fault signalling contact	1	1	1	1
Shunt release or undervoltage release	1	1	1	1

MPCB's MPX³

Cat. N°(s) : 4 173 00...4 173 15, 4 173 20...4 173 35,
4 173 40...4 173 55, 4 173 60...4 173 68,
4 173 70...4 173 79



CONTENTS	PAGES
1. Description - Use	1
2. Range	1
3. Overall dimensions	1
4. Installation - Connection	2
5. General characteristics	3
6. Conformities and approvals	12
7. Curves	13
8. Auxiliaries and accessories	23

1. DESCRIPTION - USE

Thermal-magnetic circuit breaker with positive contact indication for control, protection and isolation of electrical circuits supplying electrical motors.

Symbol:

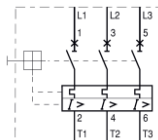

2. RANGE

Number of Poles:

. Triple pole (3P).

Rated current In:

. 0.16A, 0.25A, 0.4A, 0.63A, 1A, 1.6A, 2.5A, 4A, 6A, 8A, 10A, 13A, 17A, 22A, 26A, 32A, 40A, 50A, 63A, 75A, 90A, 100A.

Magnetic threshold:

. 13 Ie Max

Rated Voltage / Frequency:

. 400 / 415 V ~, 50 / 60 Hz with standard tolerances.

Operating voltage:

. 230 / 240 V ~.
. 400 / 415 V ~.
. 440 / 460 V ~.
. 500 / 525 V ~.
. 600 / 690 V ~.

Thermal tripping class:

. Class 10A in accordance with IEC 60 947.

Utilisation category:

. Category A in accordance with IEC 60947-2.
. Category A C-3 in accordance with IEC 60947-4-1.

Suitability for isolation:

. In accordance with IEC 60947-1.

3. OVERALL DIMENSIONS

MPX³ 32S:

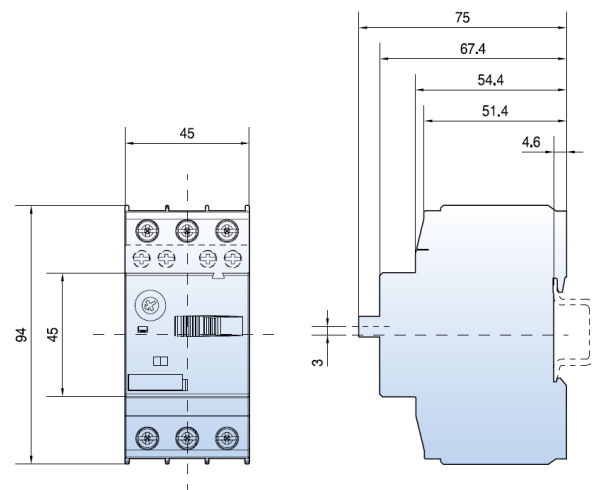

MPX³ 32H / MPX³ 32MA:

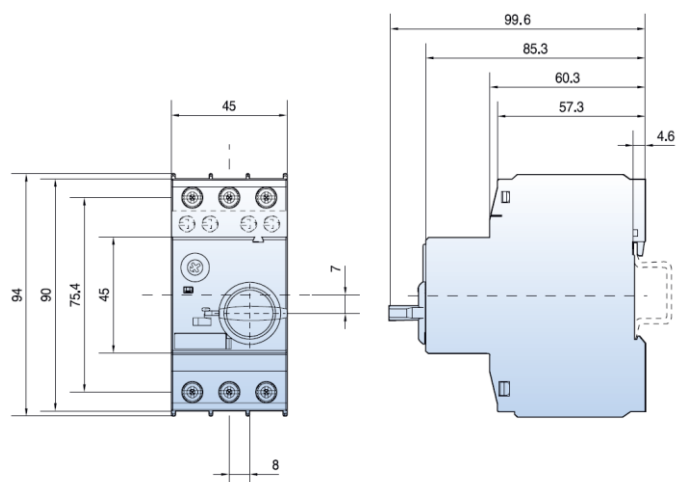

3. OVERALL DIMENSIONS (continued)

MPX³ 63H:

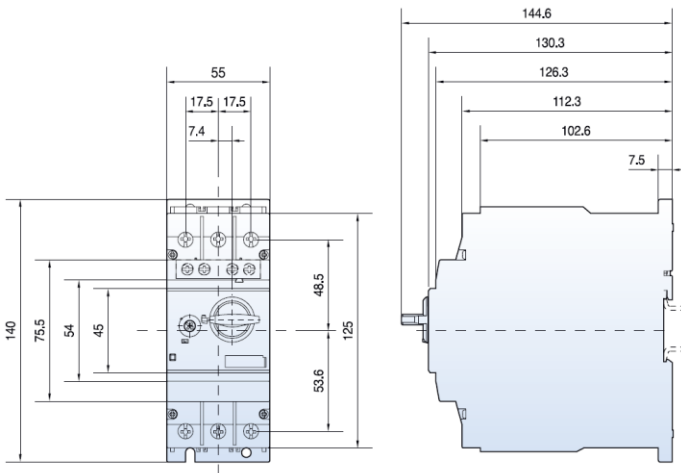

MPX³ 100H:

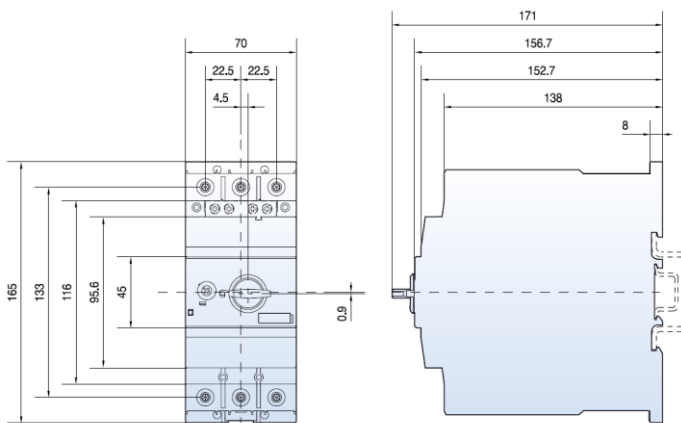

4. INSTALLATION - CONNECTION

Fixing:

- . 35mm DIN rail for MPX³ 32S / MPX³ 32H / MPX³ 32MA.
- . 35mm DIN rail for MPX³ 63H, or with screws.
- . 35mm or 75 mm DIN rail for MPX³ 100H, or with screws.
- use 15 mm depth for 35 mm DIN rail

Operating position:

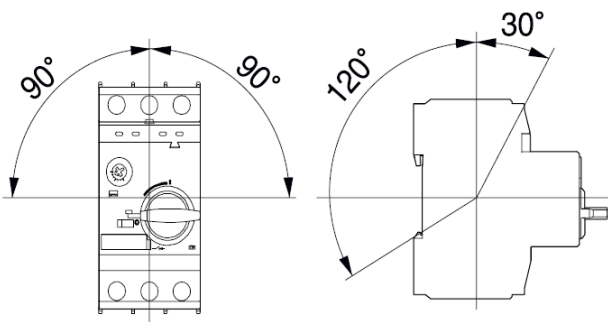

4. INSTALLATION - CONNECTION (continued)

Supply:

- . Either from the top or the bottom.

Type of wire:

- . For MPX³ 32S / MPX³ 32H / MPX³ 32MA

	MPX ³ 32S	MPX ³ 32H MPX ³ 32MA
Terminal parts		
Single-core	1.conductor [mm ²] / [AWG] 1...10 / 18...8	1...10 / 18...8
	2.conductor [mm ²] / [AWG] 1...6 / 18...10	1...6 / 18...10
Standard	1.conductor [mm ²] / [AWG] 1...6 / 18...10	1...6 / 18...10
	2.conductor [mm ²] / [AWG] 1...6 / 18...10	1...6 / 18...10
Flexible	1.conductor [mm ²] / [AWG] 1...6 / 18...10	1...6 / 18...10
	2.conductor [mm ²] / [AWG] 0.75...4 / 18...10	0.75...4 / 18...10
Tightening torque	[Nm] / [lb-in] 0.8...2.5 / 7...22	0.8...2.5 / 7...22

- . For MPX³ 63H / MPX³ 100H

	MPX ³ 63H	MPX ³ 100H
Terminal parts		
Single-core	1.conductor [mm ²] / [AWG] 0.75...35 / 18...2	2.5...70 / 12...2/0
	2.conductor [mm ²] / [AWG] 0.75...25 / 18...4	2.5...50 / 12...1/0
Standard	1.conductor [mm ²] / [AWG] 0.75...35 / 18...2	2.5...70 / 12...2/0
	2.conductor [mm ²] / [AWG] 0.75...25 / 18...4	2.5...50 / 12...1/0
Flexible	1.conductor [mm ²] / [AWG] 0.75...25 / 18...4	2.5...50 / 12...1/0
	2.conductor [mm ²] / [AWG] 0.75...16 / 18...6	2.5...35 / 10...2
Tightening torque	[Nm] / [lb-in] 3...4.5 / 26...39	4...6 / 35...53

Connection :

- . Terminals protected against direct contact (IP20).
- . Terminals with release and captive screws.
- . Screw head : slotted and pozidriv n°2.
- (for MPX³ 32S, 32H, 32MA and MPX³ 63H)
- . Allen key 4 [mm] (for MPX³ 100H).

Tools required:

- . Posidriv N°2 screwdriver recommended.
- . Flat screwdriver Ø5 to Ø6 [mm] Maximum.

Manual actuation:

- . Ergonomic 2 positions rocker: (for MPX³ 32S)
- . Ergonomic 2 positions rotary handle: (for MPX³ 32H / MPX³ 32MA and MPX³ 63H)
 - O : Device open.
 - I : Device closed.
- . Ergonomic 3 positions rotary handle: (for MPX³ 100H)
 - O : Device open.
 - TRIP : Device open.
 - I : Device closed.

4. INSTALLATION - CONNECTION *(continued)*

Contact status display:

- . For MPX³ 32S / MPX³ 32H / MPX³ 32MA and MPX³ 63H
 - By permanent laser marking:
 - . "O-OFF" = contacts open.
 - . "I-ON" = contacts closed.
- . For MPX 100H:
 - By permanent laser marking:
 - . "O-OFF" = contacts open.
 - . "TRIP" = contacts open (indication on current fault).
 - . "I-ON" = contacts closed.

Sealing:

- . With dial Cover MPX³ (cat n° 4 174 79).

Locking possibility:

- . By 4.5 [mm] padlock, in the open position - "OFF".

Labelling:

- . Identification labelling area situated on the front of the product.

5. GENERAL CHARACTERISTICS

Front side:

- . By permanent laser marking:

- Brand: Legrand
- Range: MPX³
- Rated current (in A)
- O Off / ON I
- TEST
- Electric diagram
- Thermal adjustment ring
- Ultimate short-circuit breaking capacity (Icu)
- Rated service short-circuit breaking capacity (Ics)
- Marking power terminals

MPX³ 32S: (Example of marking)

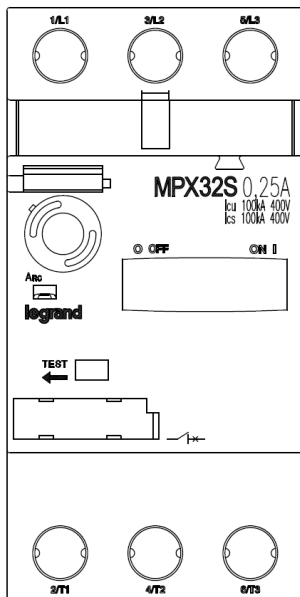

5. GENERAL CHARACTERISTICS *(continued)*

Front side: *(continued)*

MPX³ 32H: (Example of marking)

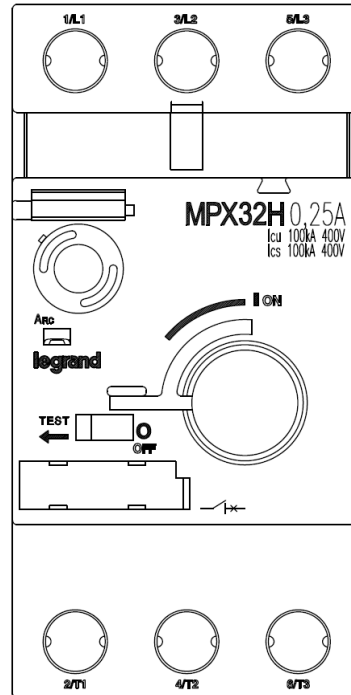

MPX³ 32MA: (Example of marking)

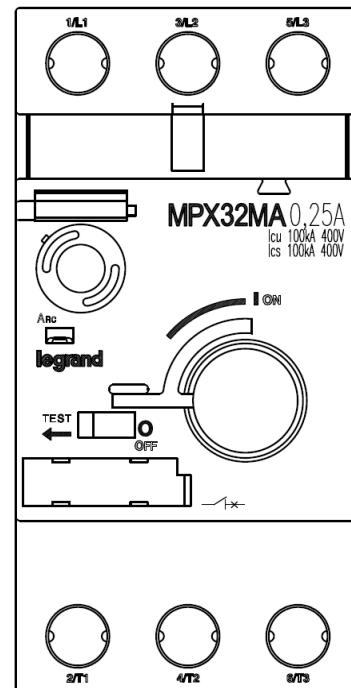

5. GENERAL CHARACTERISTICS (continued)

Front side: (continued)

MPX³ 63H: (Example of marking)

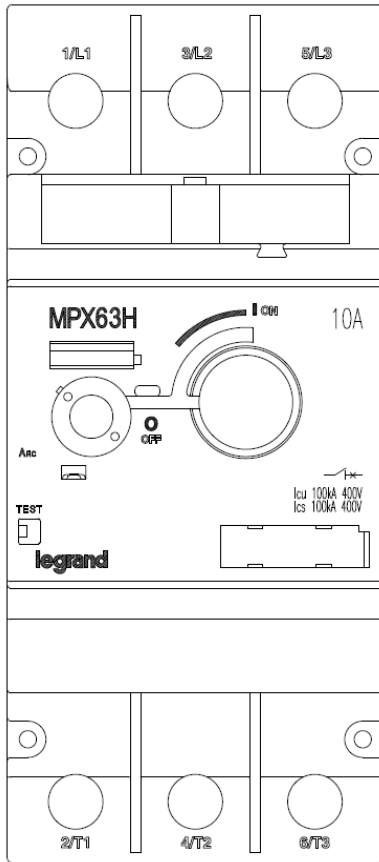

MPX³ 100H: (Example of marking)

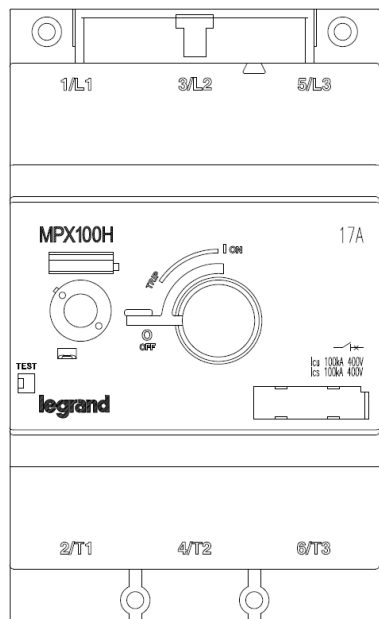

5. GENERAL CHARACTERISTICS (continued)

Front side: (continued)

Left side:

. By identification label (referring to IEC standard)

legrand MPX³ 4 173 00

Cat.A / AC-3 $U_i = 690V$ 50/60Hz $U_{imp} = 6kV$
 $I_e = 0.1-0.16A$ $I_{t \rightarrow \infty} >$ 2.1A Trip Class 10

U_e (V)	I_{cu} (kA)	I_{cs} (kA)	$I_{cc} > I_{cu}$ gL / gG
230 / 240	100	100	-
400 / 415	100	100	-
440 / 460	100	100	-
500 / 525	100	100	-
600 / 690	100	100	-

1 x 1 ... 10mm² 1 x 1 ... 6mm²
 2 x 1 ... 6mm² 2 x 1 ... 6mm²

PZ2/∅ 5...6mm
 2.0Nm

IEC/EN 60947 VDE 0660

CE

140626 YS

MADE IN KOREA

Right side:

. By identification label (referring to UL standard)

MANUAL MOTOR CONTROLLER

MAX. FUSE OR CB 500A

SHORT CIRCUIT CURRENT RATING,
RMS, SYM: 50kA 480V/277V, 10kA 600V/347V

SUITABLE FOR USE WITH LOAD SIDE CONTROLLERS MARKED FOR USE WITH THIS PRODUCT.
FOR USE WITH DESIGN E MOTORS.
USE ALL 3 POLES

V AC	115	200	230	460	575
3PH,HP	-	-	-	-	1/2
1PH,HP	-	-	-	-	-

1.0 FLA MAX; DIAL IS FLA. TRIP AMPS 125%;
USE 75°C CU WIRE ONLY; BREAK ALL LINES

TORQUE	WIRE RANGE
18LB IN	1x18 TO 8 AWG
	2x18 TO 10 AWG

7961 1912 035

WARNING:
IF AN OVERLOAD OR A FAULT CURRENT INTERRUPTION OCCURS, CIRCUITS MUST BE CHECKED TO DETERMINE THE CAUSE OF THE INTERRUPTION. IF A FAULT CONDITION EXISTS, THE CURRENT-CARRYING COMPONENTS SHOULD BE EXAMINED AND REPLACED IF DAMAGED, AND THE INTEGRAL CURRENT SENSORS MUST BE REPLACED TO REDUCE THE RISK OF FIRE OR ELECTRIC SHOCK. TO MAINTAIN OVERCURRENT, SHORT-CIRCUIT, AND GROUND-FAULT PROTECTION, THE MANUFACTURER'S INSTRUCTIONS FOR SELECTION OF OVERLOAD AND SHORT CIRCUIT PROTECTION MUST BE FOLLOWED TO REDUCE THE RISK OF FIRE OR ELECTRIC SHOCK.

5. GENERAL CHARACTERISTICS (continued)

Setting ranges:

Rated operational current (I _e)	Thermal release adjustment range (I _r)
0.16 [A]	0.1~0.16 [A]
0.25 [A]	0.16~0.25 [A]
0.4 [A]	0.25~0.4 [A]
0.63 [A]	0.4~0.63 [A]
1 [A]	0.63~1 [A]
1.6 [A]	1~1.6 [A]
2.5 [A]	1.6~2.5 [A]
4 [A]	2.5~4 [A]
6 [A]	4~6 [A]
8 [A]	5~8 [A]
10 [A]	6~10 [A]
13 [A]	9~13 [A]
17 [A]	11~17 [A]
22 [A]	14~22 [A]
26 [A]	18~26 [A]
32 [A]	22~32 [A]
40 [A]	28~40 [A]
50 [A]	34~50 [A]
63 [A]	45~63 [A]
75 [A]	55~75 [A]
90 [A]	70~90 [A]
100 [A]	80~100 [A]

Rated operational voltage:

- . U_e = 690 [V] for all products conforming to IEC60947-2.
- . U_e = 600 [V] for all products conforming to UL508

Rated impulse voltage:

- . U_{imp} = 6 kV for MPX³ 32S / MPX³ 32H / MPX³ 32MA.
- . U_{imp} = 8 kV for MPX³ 63H / MPX³ 100H.

Rated insulation voltage:

- . U_i = 690 V for MPX³ 32S / MPX³ 32H / MPX³ 32MA.
- . U_i = 1000 V for MPX³ 63H / MPX³ 100H.

Mechanical endurance:

- . 100 000 operations for MPX³ 32S / MPX³ 32H / MPX³ 32MA.
- . 50 000 operations for MPX³ 63H / MPX³ 100H.

Electrical endurance:

- . 100 000 cycles for MPX³ 32S / MPX³ 32H / MPX³ 32MA.
- . 25 000 cycles for MPX³ 63H / MPX³ 100H.

Max operating frequency per hour:

- . 25 operations per hour.

5. GENERAL CHARACTERISTICS (continued)

Ambient operating temperature:

- . Min. = -20°C. Max. = +60°C.

Ambient storage temperature:

- . Min. = -50°C. Max. = +80°C.

Overload protection:

- . No overload protection for MPX³ 32MA.

Phase failure protection:

- . All products.

Test function:

- . All products.

Weight:

MPX ³	Weight
MPX ³ 32S	0.32 [kg]
MPX ³ 32H	0.36 [kg]
MPX ³ 32MA	0.36 [kg]
MPX ³ 63H	1 [kg]
MPX ³ 100H	2.2 [kg]

Maximum operating altitude:

- . 2000 [m].

Protection degree:

- . IP20.

Flame resistance:

- . Conforming to UL = V0.
- . Conforming to IEC 695-2-1 = 960 [°C].

Shock resistance:

- . 25 [g].

Vibration resistance:

- . 5~150 [Hz].

Power consumption:

	MPX ³ 32S	MPX ³ 32H / MA
Total power loss circuit breaker at rated load operating temperature	I _n = 0.16~1.6 [A] 4.4 [W]	I _n = 0.16~1.6 [A] 4.4 [W]
	I _n = 2.5~26 [A] 7.4 [W]	I _n = 2.5~26 [A] 7.4 [W]
	I _n = 32 [A] 4 [W]	I _n = 32 [A] 4 [W]
Total power loss circuit breaker at rated load operating temperature	MPX ³ 63H	MPX ³ 100H
	I _n = 10~22 [A] 10.2 [W]	I _n = 17~32 [A] 15 [W]
	I _n = 26~63 [A] 9.7 [W]	I _n = 40~63 [A] 21.8 [W]
	-	I _n = 75~100 [A] 17.8 [W]

5. GENERAL CHARACTERISTICS (continued)

Breaking capacity: In accordance with IEC 60 947-2 standard
. For MPX³ 32S

Rated operational current - Ie [A]		0.16	0.25	0.4	0.63	1	1.6	2.5	4	6	8	10	13	17	22	26	32
Switching of standard three-phase motors AC-2, AC-3	230 / 240 [V] [kW]	-	0.03	0.06	0.09	0.12	0.18/ 0.25	0.37	0.55/ 0.75	1.1/ 1.5	1.5	2.2/3	3	3.7/4	4	5.5	7.5
	400 / 415 [V] [kW]	0.02	0.06	0.09	0.12	0.18/ 0.25	0.37/ 0.55	0.75	1.1/ 1.5	2.2	3	3.7/4	5.5	7.5	7.5	11	15
	500 [V] [kW]	-	-	-	0.25	0.37	0.55/ 0.75	1.1	1.5/ 2.2	3	3.7	4/5.5	7.5	11	11	15	18.5
	690 [V] [kW]	-	-	-	0.25	0.37/ 0.55	0.75/ 1.1	1.5	2.2/3	3.7/4	5.5	7.5	11	11	15	18.5	22
Ultimate short-circuit breaking capacity (Icu)	230 / 240 [V] [kA]	100	100	100	100	100	100	100	100	100	100	100	100	50	40	40	30
	400 / 415 [V] [kA]	100	100	100	100	100	100	100	100	100	100	100	50	50	20	15	15
	440 / 460[V] [kA]	100	100	100	100	100	100	100	50	15	10	10	6	6	6	6	5
	500 [V] [kA]	100	100	100	100	100	100	50	15	10	10	6	6	6	6	5	5
Rated service short-circuit breaking capacity (Ics)	230 / 240 [V] [kA]	100	100	100	100	100	100	100	100	100	100	100	100	38	30	30	22
	400 / 415 [V] [kA]	100	100	100	100	100	100	100	100	100	100	38	38	15	11	11	11
	440 / 460[V] [kA]	100	100	100	100	100	100	100	38	11	11	11	8	8	6	6	4
	500 [V] [kA]	100	100	100	100	100	100	38	11	8	8	5	5	5	5	4	4
Rated service short-circuit breaking capacity of one single pole	230 / 240 [V] [kA]	100	100	100	100	100	100	100	100	100	100	38	38	15	11	11	11
	400 / 415 [V] [kA]	100	100	100	100	100	3	3	3	3	3	3	3	3	3	3	3

. In accordance with UL 508 certification

Rated operational current - Ie [A]		0.16	0.25	0.4	0.63	1	1.6	2.5	4	6	8	10	13	17	22	26	32
Max. short-circuit current																	
	240 [V] [kA]	100	100	100	100	100	100	100	100	100	100	50	50	40	30	30	20
	480 [V] [kA]	50	50	50	50	50	50	50	50	50	25	25	10	10	10	7.5	7.5
	600 [V] [kA]	10	10	10	10	10	10	10	10	5	5	5	5	5	5	5	5
Motor load																	
1 Phase	115 [V] [HP]	-	-	-	-	-	-	-	1/8	1/4	1/3	1/2	1/2	1	1 1/2	2	2
	230 [V] [HP]	-	-	-	-	-	-	1/10	1/6	1/3	1/2	1	1 1/2	2	3	3	5
3 Phase	200 [V] [HP]	-	-	-	-	-	-	1/2	3/4	1	2	2	3	3	5	7 1/2	7 1/2
	230 [V] [HP]	-	-	-	-	-	-	1/2	3/4	1 1/2	2	3	3	5	7 1/2	7 1/2	10
	460 [V] [HP]	-	-	-	-	-	3/4	1	2	3	5	5	7 1/2	10	15	15	20
	575 [V] [HP]	-	-	-	-	1/2	3/4	1 1/2	3	5	5	7 1/2	10	15	20	20	30
Max. Fuse size [A]		1	1	1	1	3	6	10	15	20	30	40	50	60	80	100	125
Max. Breaker size [A]		15	15	15	15	15	15	15	15	20	30	40	50	60	80	100	125

5. GENERAL CHARACTERISTICS (continued)

Breaking capacity: In accordance with IEC 60 947-2 standard
. For MPX³ 32H and 32MA

Rated operational current - Ie [A]		0.16	0.25	0.4	0.63	1	1.6	2.5	4	6	8	10	13	17	22	26	32
Switching of standard three-phase motors AC-2, AC-3	230 / 240 [V] [kW]	-	0.03	0.06	0.09	0.12	0.18/0.25	0.37	0.55/0.75	1.1/1.5	1.5	2.2/3	3	3.7/4	4	5.5	7.5
	400 / 415 [V] [kW]	0.02	0.06	0.09	0.12	0.18/0.25	0.37/0.55	0.75	1.1/1.5	2.2	3	3.7/4	5.5	7.5	7.5	11	15
	500 [V] [kW]	-	-	-	0.25	0.37	0.55/0.75	1.1	1.5/2.2	3	3.7	4/5.5	7.5	11	11	15	18.5
	690 [V] [kW]	-	-	-	0.25	0.37/0.55	0.75/1.1	1.5	2.2/3	3.7/4	5.5	7.5	11	11	15	18.5	22
Ultimate short-circuit breaking capacity (Icu)	230 / 240 [V] [kA]	100	100	100	100	100	100	100	100	100	100	100	100	100	100	100	100
	400 / 415 [V] [kA]	100	100	100	100	100	100	100	100	100	100	100	100	50	50	50	50
	440 / 460[V] [kA]	100	100	100	100	100	100	100	100	100	50	50	50	20	20	20	20
	500 [V] [kA]	100	100	100	100	100	100	100	100	100	50	50	42	10	10	10	10
Rated service short-circuit breaking capacity (Ics)	230 / 240 [V] [kA]	100	100	100	100	100	100	100	100	100	100	100	100	100	100	100	100
	400 / 415 [V] [kA]	100	100	100	100	100	100	100	100	100	100	100	100	38	38	38	38
	440 / 460[V] [kA]	100	100	100	100	100	100	100	100	100	38	38	38	15	15	15	15
	500 [V] [kA]	100	100	100	100	100	100	100	100	100	38	38	32	8	8	8	8
Rated service short-circuit breaking capacity of one single pole	230 / 240 [V] [kA]	100	100	100	100	100	100	100	100	100	100	100	100	38	38	38	38
	400 / 415 [V] [kA]	100	100	100	100	100	100	8	8	6	6	6	6	4	4	4	4

. In accordance with UL 508 certification

Rated operational current - Ie [A]		0.16	0.25	0.4	0.63	1	1.6	2.5	4	6	8	10	13	17	22	26	32
Max. short-circuit current																	
	240 [V] [kA]	100	100	100	100	100	100	100	100	100	100	100	100	100	100	100	100
	480 [V] [kA]	50	50	50	50	50	50	50	50	50	50	50	50	30	30	30	30
	600 [V] [kA]	10	10	10	10	10	10	10	10	10	10	10	10	10	10	10	10
Motor load																	
1 Phase	115 [V] [HP]	-	-	-	-	-	-	-	1/8	1/4	1/3	1/2	1/2	1	1 1/2	2	2
	230 [V] [HP]	-	-	-	-	-	1/10	1/6	1/3	1/2	1	1 1/2	2	3	3	3	5
3 Phase	200 [V] [HP]	-	-	-	-	-	-	1/2	3/4	1	2	2	3	3	5	7 1/2	7 1/2
	230 [V] [HP]	-	-	-	-	-	-	1/2	3/4	1 1/2	2	3	3	5	7 1/2	10	15
	460 [V] [HP]	-	-	-	-	-	3/4	1	2	3	5	5	7 1/2	10	15	15	20
	575 [V] [HP]	-	-	-	-	1/2	3/4	1 1/2	3	5	5	7 1/2	10	15	20	20	30
Max. Fuse size	[A]	1	1	1	1	3	6	10	15	20	30	40	50	60	80	100	125
Max. Breaker size	[A]	15	15	15	15	15	15	15	15	20	30	40	50	60	80	100	125

5. GENERAL CHARACTERISTICS (continued)

Breaking capacity: (continued)

. For MPX³ 63H

Rated operational current - I _e [A]			10	13	17	22	26	32	40	50	63
Switching of standard three-phase motors AC-2, AC-3	230 / 240 [V]	[kW]	2,2/3	3	3,7/4	4	5,5	7,5	7,5	11	15
	400 / 415 [V]	[kW]	3,7/4	5,5	7,5	7,5	11	15	18,5	22	30
	500 [V]	[kW]	4/5,5	7,5	11	11	15	18,5	22	30	37
	690 [V]	[kW]	7,5	11	11	15	18,5	22	30	45	55
Ultimate short-circuit breaking capacity (I _{cu})	230 / 240 [V]	[kA]	100	100	100	100	100	100	100	100	100
	400 / 415 [V]	[kA]	100	100	50	50	50	50	50	50	50
	440 / 460[V]	[kA]	50	50	50	50	35	35	35	35	35
	500 [V]	[kA]	50	42	12	12	12	10	10	10	10
Rated service short-circuit breaking capacity (I _{cs})	230 / 240 [V]	[kA]	100	100	100	100	100	100	100	100	100
	400 / 415 [V]	[kA]	100	100	50	50	50	50	50	50	50
	440 / 460[V]	[kA]	38	38	38	38	27	27	27	27	27
	500 [V]	[kA]	38	32	9	9	9	8	8	8	8
Rated service short-circuit breaking capacity of one single pole	230 / 240 [V]	[kA]	100	100	50	50	50	50	50	50	50
	400 / 415 [V]	[kA]	5	5	5	5	5	5	5	5	5

. In accordance with UL 508 certification

Rated operational current - I _e [A]			10	13	17	22	26	32	40	50	63
Max. short-circuit current											
	240 [V]	[kA]	100	100	100	100	100	100	100	100	100
	480 [V]	[kA]	50	50	50	50	50	50	50	50	50
	600 [V]	[kA]	10	10	10	10	10	10	10	10	10
Motor load											
1 Phase	115 [V]	[HP]	1/2	1/2	1	1 1/2	2	2	3	3	5
	230 [V]	[HP]	1 1/2	2	3	3	3	5	7 1/2	10	10
3 Phase	200 [V]	[HP]	2	3	3	5	7 1/2	7 1/2	10	15	20
	230 [V]	[HP]	3	3	5	7 1/2	7 1/2	10	10	15	20
	460 [V]	[HP]	5	7 1/2	10	15	15	20	30	30	40
	575 [V]	[HP]	7 1/2	10	15	20	20	30	30	40	60
Max. Fuse size		[A]	40	50	60	80	100	125	150	200	250
Max. Breaker size		[A]	40	50	60	80	100	125	150	200	250

5. GENERAL CHARACTERISTICS (continued)

Breaking capacity: (continued)

. For MPX³ 100H

Rated operational current - I _e [A]			17	22	26	32	40	50	63	75	90	100
Switching of standard three-phase motors AC-2, AC-3	230 / 240 [V]	[kW]	3.7/4	4	5.5	7.5	7.5	11	15	22	30	30
	400 / 415 [V]	[kW]	7.5	7.5	11	15	18.5	22	30	37	45	45
	500 [V]	[kW]	11	11	15	18.5	22	30	37	45	55	63
	690 [V]	[kW]	11	15	18.5	22	30	45	55	63	75	90
Ultimate short-circuit breaking capacity (I _{cu})	230 / 240 [V]	[kA]	100	100	100	100	100	100	100	100	100	100
	400 / 415 [V]	[kA]	100	100	100	100	100	100	100	75	75	75
	440 / 460[V]	[kA]	50	50	50	50	50	50	50	50	50	50
	500 [V]	[kA]	35	35	35	25	20	15	15	12	12	12
	690 [V]	[kA]	12	12	12	12	12	10	8	6	6	6
Rated service short-circuit breaking capacity (I _{cs})	230 / 240 [V]	[kA]	100	100	100	100	100	100	100	100	100	100
	400 / 415 [V]	[kA]	100	50	50	50	50	50	50	50	50	50
	440 / 460[V]	[kA]	38	38	38	38	38	38	38	38	38	38
	500 [V]	[kA]	27	27	27	19	15	11	11	9	9	9
	690 [V]	[kA]	9	9	9	9	9	8	6	6	6	6
Rated service short-circuit breaking capacity of one single pole	230 / 240 [V]	[kA]	100	50	50	50	50	50	50	50	50	50
	400 / 415 [V]	[kA]	9	9	9	9	9	8	6	6	6	6

. In accordance with UL 508 certification

Rated operational current - I _e [A]			17	22	26	32	40	50	63	75	90	100
Max. short-circuit current												
	240 [V]	[kA]	100	100	100	100	100	100	100	100	100	100
	480 [V]	[kA]	50	50	50	50	50	50	50	50	50	50
	600 [V]	[kA]	10	10	10	10	10	10	10	10	10	10
Motor load												
1 Phase	115 [V]	[HP]	1	1½	2	2	3	3	5	5	7½	10
	230 [V]	[HP]	3	3	3	5	7½	10	10	15	20	20
3 Phase	200 [V]	[HP]	3	5	7½	7½	10	15	20	20	25	30
	230 [V]	[HP]	5	7½	7½	10	10	15	20	25	30	30
	460 [V]	[HP]	10	15	15	20	30	30	40	50	60	75
	575 [V]	[HP]	15	20	20	30	30	40	60	60	75	100
Max. Fuse size		[A]	60	80	100	125	150	200	250	300	350	400
Max. Breaker size		[A]	60	80	100	125	150	200	250	300	350	400

5. GENERAL CHARACTERISTICS *(continued)*

Coordination: Type 2

. According to IEC 60947-4-1

- Short circuit current : I_q = 50 [kA]
- Voltage : 230/240 [V~]
- Frequency : 50/60 [Hz]

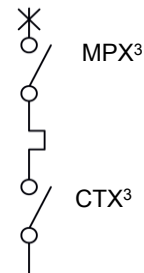

Motor		MPX ³		CTX ³
[kW]	[A]	Type	Rating In [A]	Type
0.37	1.8	MPX ³ 32H	2.5	CTX ³ 22 - 9 [A]
0.55	2.75	MPX ³ 32H	4	CTX ³ 40 - 32 [A]
0.75	3.5	MPX ³ 32H	4	
1.1	4.4	MPX ³ 63H	10	CTX ³ 40 - 40 [A]
1.5	6.1	MPX ³ 63H	10	
2.2	8.7	MPX ³ 63H	13	
3	11.5	MPX ³ 63H	13	
3.7	13.5	MPX ³ 63H	18	
4	14.5	MPX ³ 63H	18	
5.5	20	MPX ³ 63H	22	
7.5	27	MPX ³ 63H	32	
9	32	MPX ³ 100H	32	CTX ³ 100 - 85 [A]
10	35	MPX ³ 100H	40	
11	39	MPX ³ 100H	40	
15	52	MPX ³ 100H	63	
18.5	64	MPX ³ 100H	75	
22	75	MPX ³ 100H	75	
25	85	MPX ³ 100H	90	

5. GENERAL CHARACTERISTICS *(continued)*

Coordination: Type 2 *(continued)*

. According to IEC 60947-4-1

- Short circuit current : I_q = 50 [kA]
- Voltage : 400/415 [V~]
- Frequency : 50/60 [Hz]

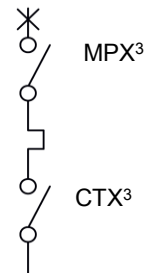

Motor		MPX ³		CTX ³
[kW]	[A]	Type	Rating In [A]	Type
0.37	1.1	MPX ³ 32S	1.6	CTX ³ 22 - 9 [A]
0.55	1.5	MPX ³ 32S	1.6	
0.75	1.9	MPX ³ 32S	2.5	CTX ³ 22 - 12 [A]
1.1	2.7	MPX ³ 32S	4	CTX ³ 22 - 18 [A]
1.5	3.6	MPX ³ 32S	4	
2.2	5.2	MPX ³ 32S	6	
3	6.8	MPX ³ 32S	8	
4	9	MPX ³ 32S	10	
5.5	11.5	MPX ³ 32H	13	CTX ³ 22 - 22 [A]
7.5	15.5	MPX ³ 32H	17	
10	20	MPX ³ 32H	22	CTX ³ 40 - 32 [A]
11	22	MPX ³ 32H	26	
15	29	MPX ³ 32H	32	
18.5	35	MPX ³ 63H	40	CTX ³ 40 - 40 [A]
22	41	MPX ³ 63H	50	CTX ³ 65 - 50 [A]
30	55	MPX ³ 63H	63	CTX ³ 65 - 65 [A]
37	67	MPX ³ 100H	75	CTX ³ 100 - 75 [A]
45	80	MPX ³ 100H	100	CTX ³ 100 - 85 [A]

5. GENERAL CHARACTERISTICS *(continued)*

Coordination: Type 2 *(continued)*

. According to IEC 60947-4-1

- Short circuit current : I_q = 50 [kA]
- Voltage : 440 [V~]
- Frequency : 50/60 [Hz]

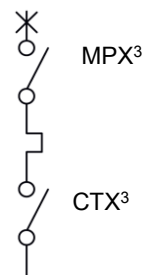

Motor		MPX ³		CTX ³
[kW]	[A]	Type	Rating In [A]	Type
0.37	0.99	MPX ³ 32S	1	CTX ³ 22 - 9 [A]
0.55	1.36	MPX ³ 32S	1.6	
0.75	1.68	MPX ³ 32S	2.5	
1.1	2.37	MPX ³ 32S	2.5	
1.5	3.06	MPX ³ 32S	4	CTX ³ 22 - 18 [A]
2.2	4.42	MPX ³ 32H	6	CTX ³ 22 - 22 [A]
3	5.57	MPX ³ 32H	6	
3.7	7.1	MPX ³ 32H	8	CTX ³ 40 - 32 [A]
4	7.9	MPX ³ 32H	8	
5.5	10.4	MPX ³ 32H	13	
9	16.9	MPX ³ 63H	17	CTX ³ 40 - 40 [A]
11	20.1	MPX ³ 63H	22	
15	26.5	MPX ³ 63H	32	
18.5	32.8	MPX ³ 63H	40	CTX ³ 65 - 50 [A]
22	39	MPX ³ 63H	40	
25	45.3	MPX ³ 63H	50	
30	51.5	MPX ³ 100H	63	CTX ³ 65 - 65 [A]
33	58	MPX ³ 100H	63	
37	64	MPX ³ 100H	63	
40	67	MPX ³ 100H	75	CTX ³ 100 - 85 [A]
45	76	MPX ³ 100H	75	

6. CONFORMITIES AND APPROVALS

Compliance to standards:

- . Standard reference: IEC/EN 60 947-2 (Breaker).
- . Standard reference: IEC/EN 60 947-4 (Motor starter).
- . Certificate of compliance with UL 508 standard.

7. CURVES

Time / Current tripping curve:

. For MPX³ 32S / MPX³ 32H / MPX³ 32MA

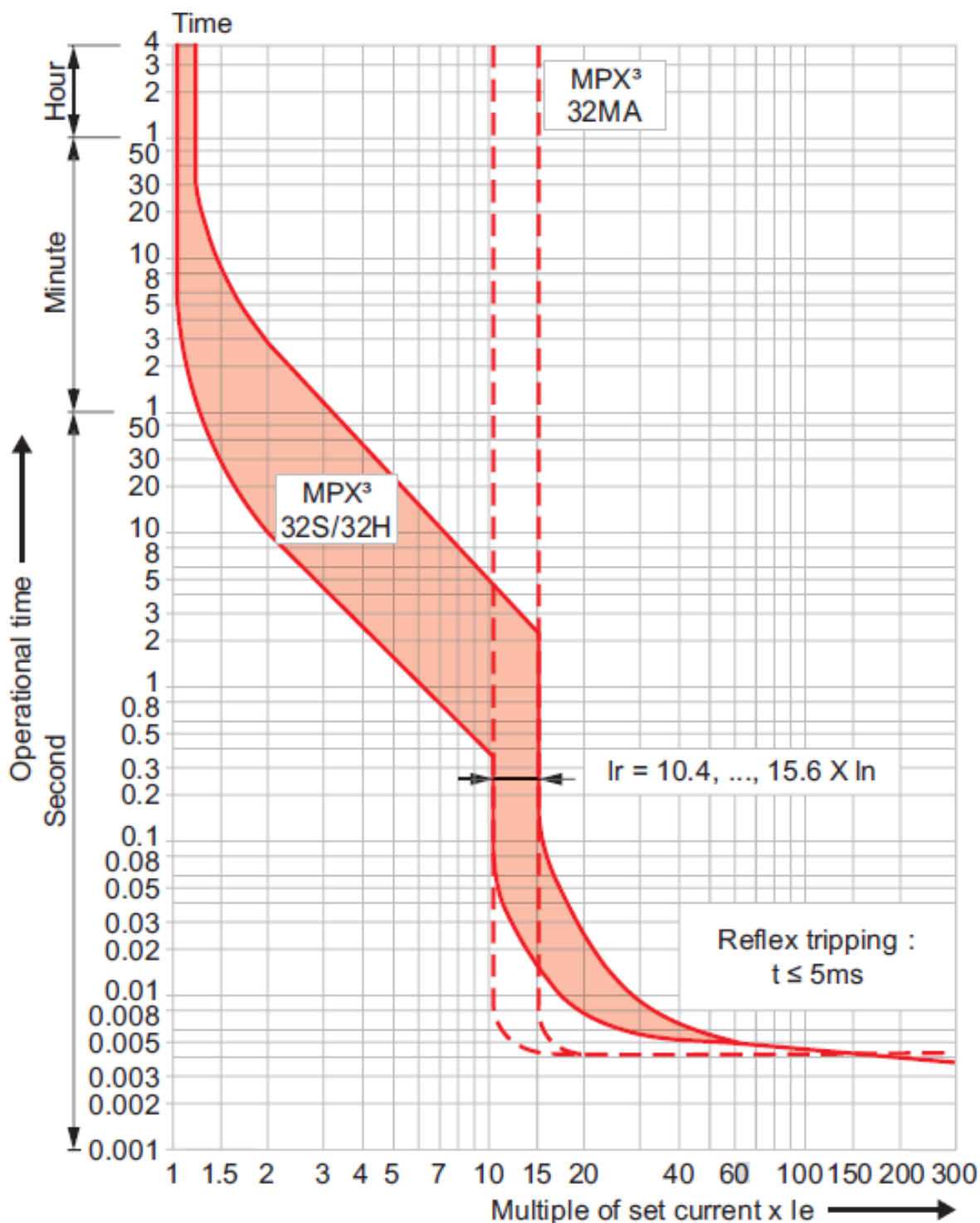

7. CURVES (continued)

Time / Current tripping curve:
. For MPX³ 63H / MPX³ 100H

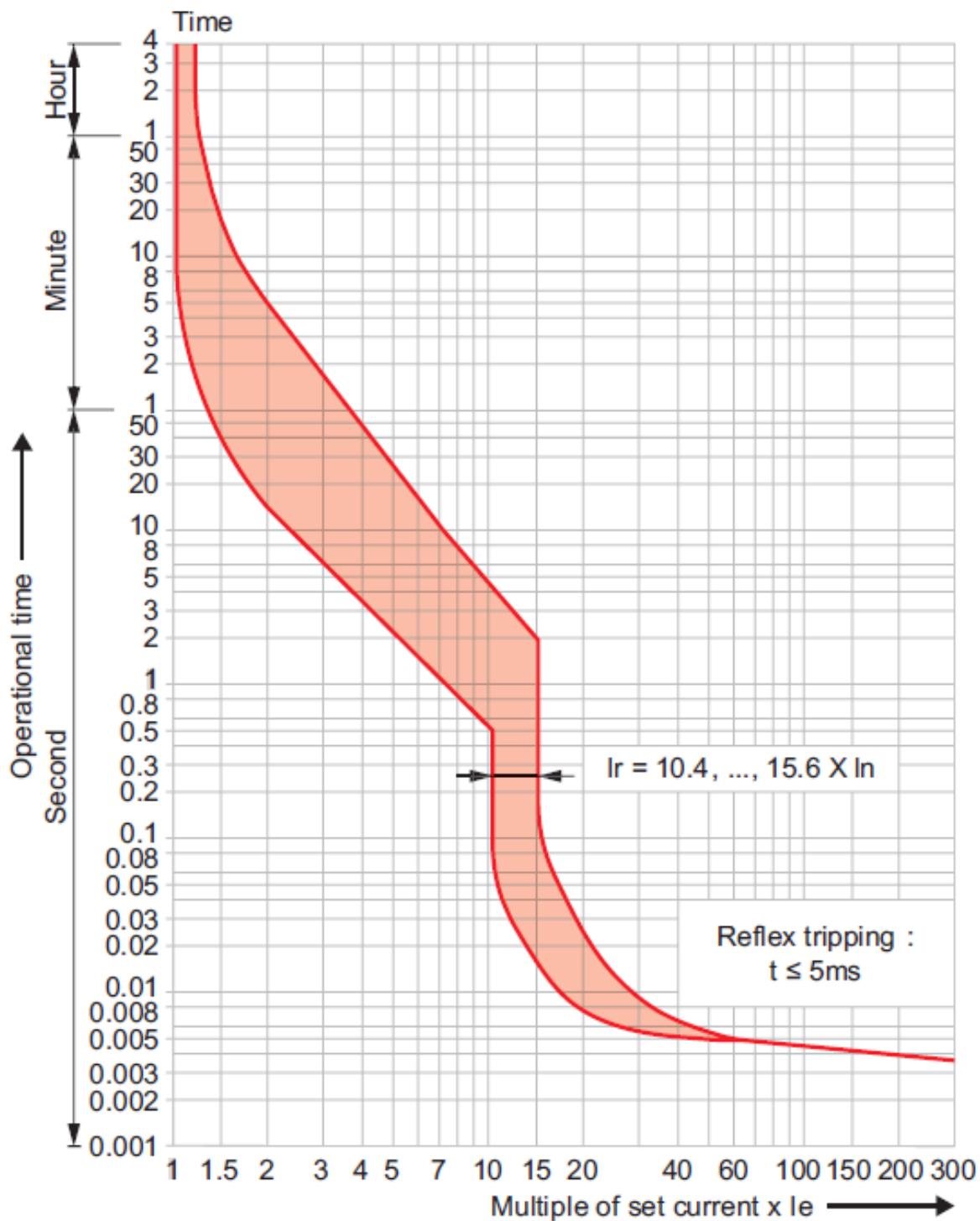

7. CURVES (continued)

Thermal limit on short circuit (U_e = 415V) :
. For MPX³ 32S

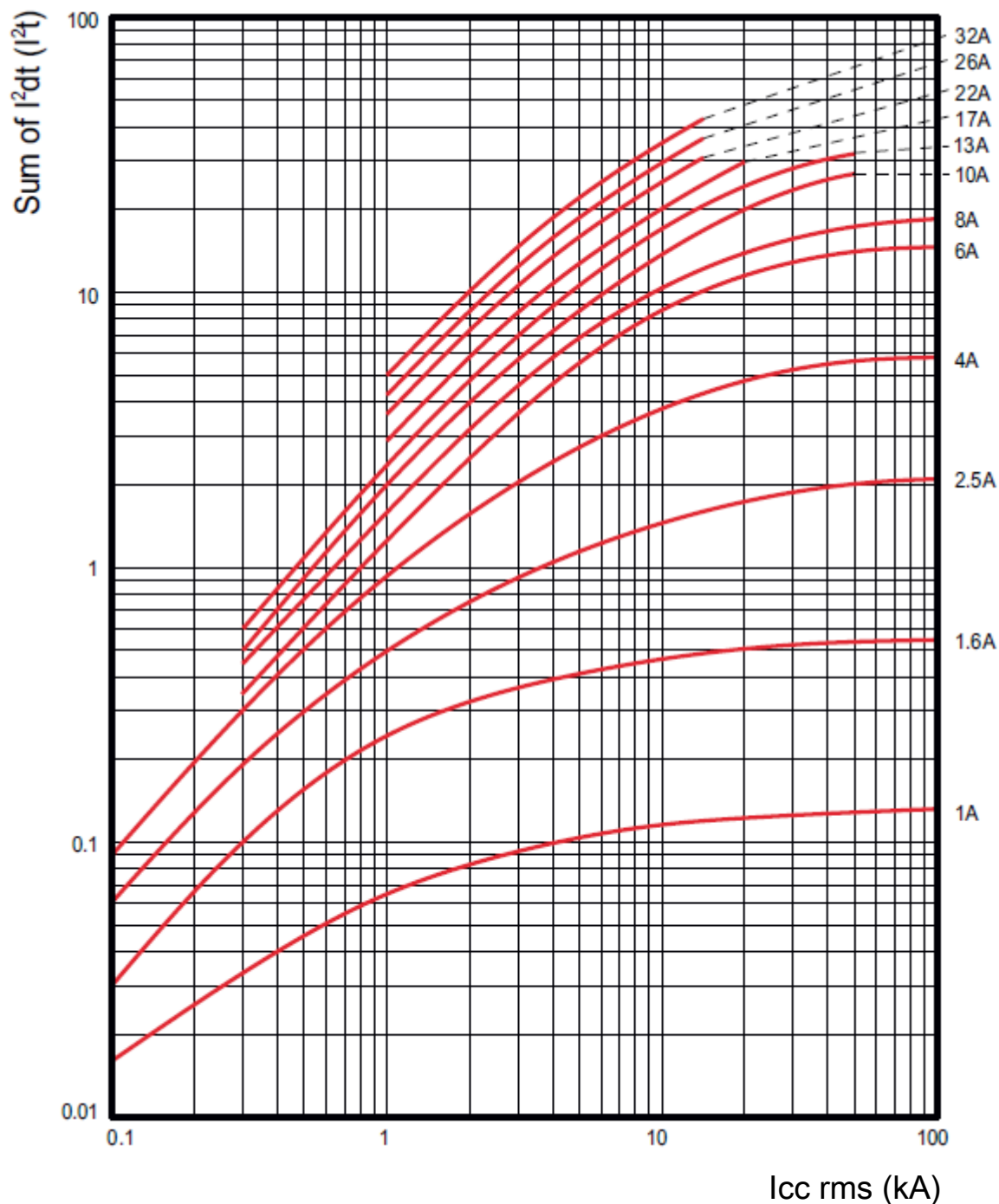

. I_{cc} = Square value of symmetric component of the short circuit current (kA).
. I²t = Thermal energy limited (kA²s).

7. CURVES (continued)

Thermal limit on short circuit (U_e = 415V) :
. For MPX³ 32H / MPX³ 32MA

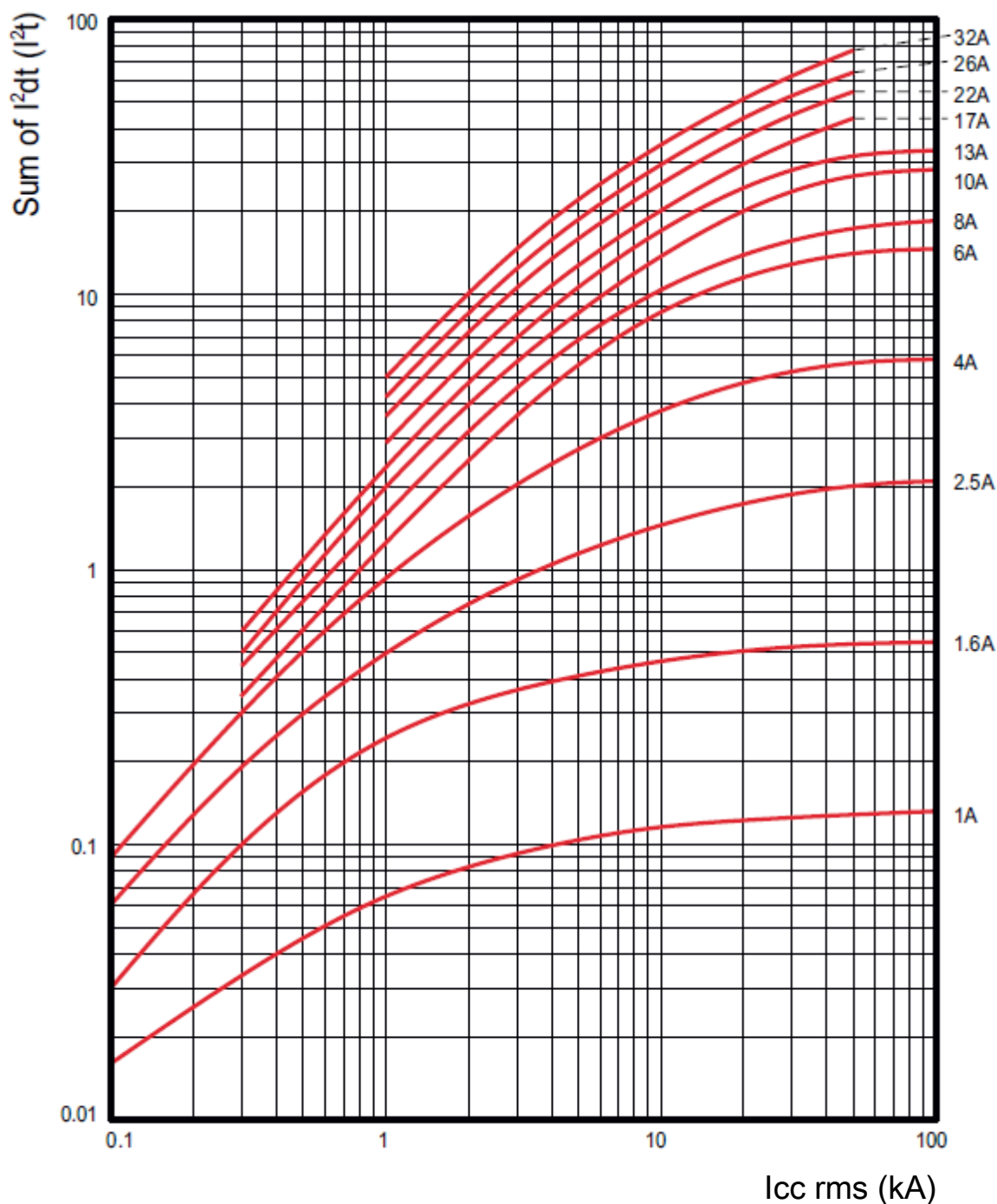

. I_{cc} = Square value of symmetric component of the short circuit current (kA).
. I²t = Thermal energy limited (kA²s).

7. CURVES (continued)

Thermal limit on short circuit (U_e = 415V) :
. For MPX³ 63H

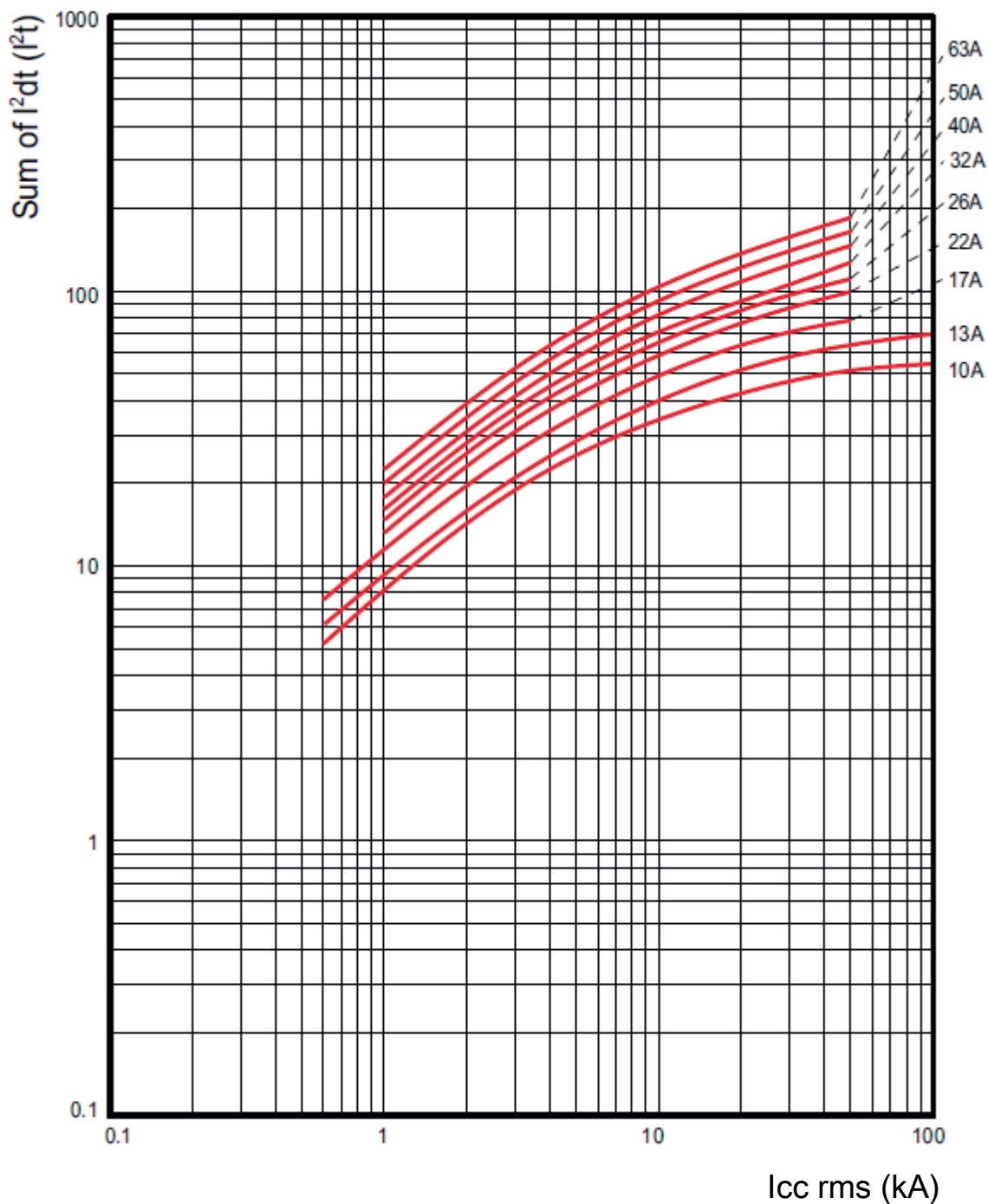

. I_{cc} = Square value of symmetric component of the short circuit current (kA).
. I²t = Thermal energy limited (kA²s).

7. CURVES (continued)

Thermal limit on short circuit (U_e = 415V) :

. For MPX³ 100H

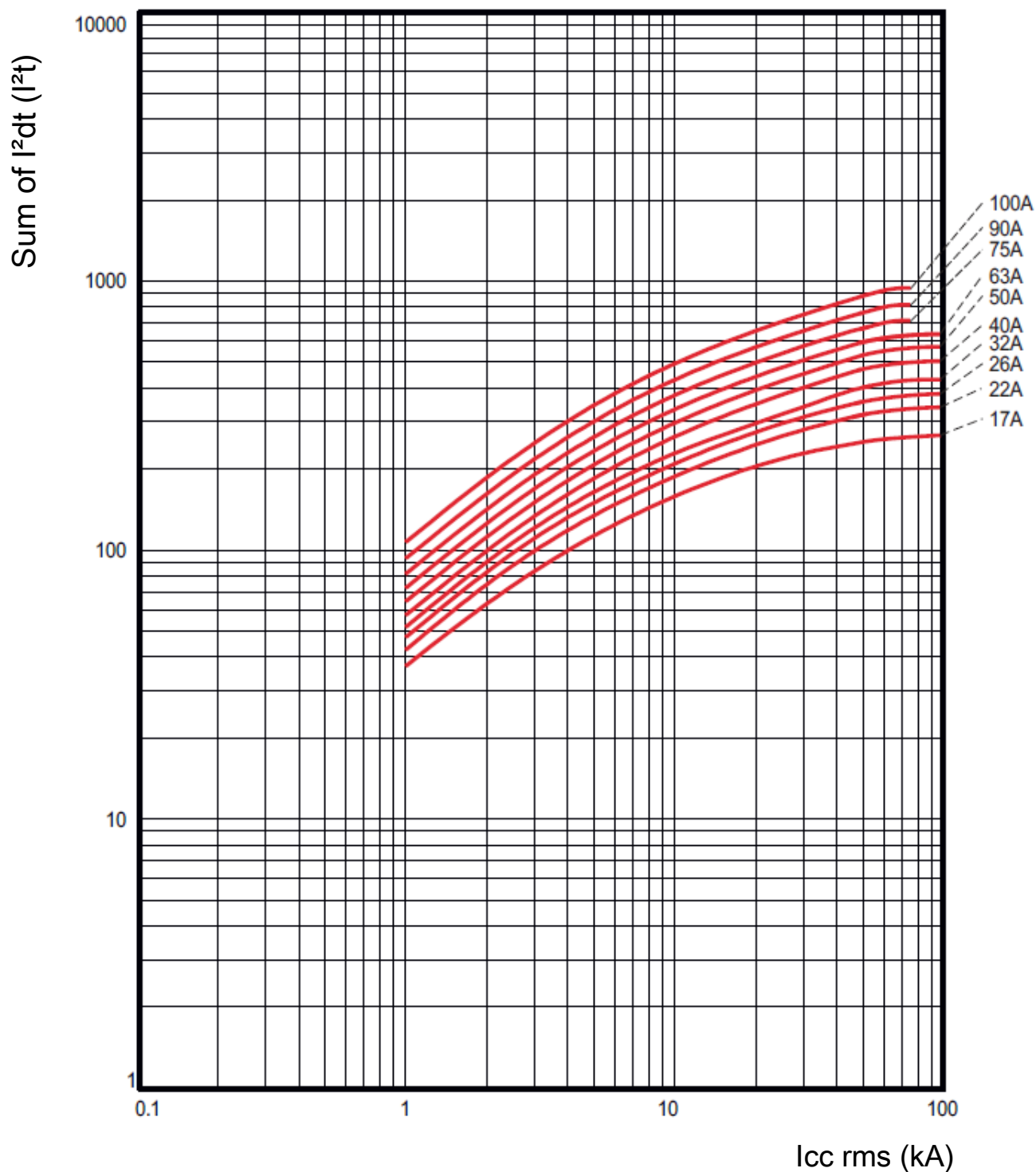

. I_{cc} = Square value of symmetric component of the short circuit current (kA).

. I²t = Thermal energy limited (kA²s).

7. CURVES (continued)

Peak current in kA ($U_e = 415V$) :

. For MPX³ 32S

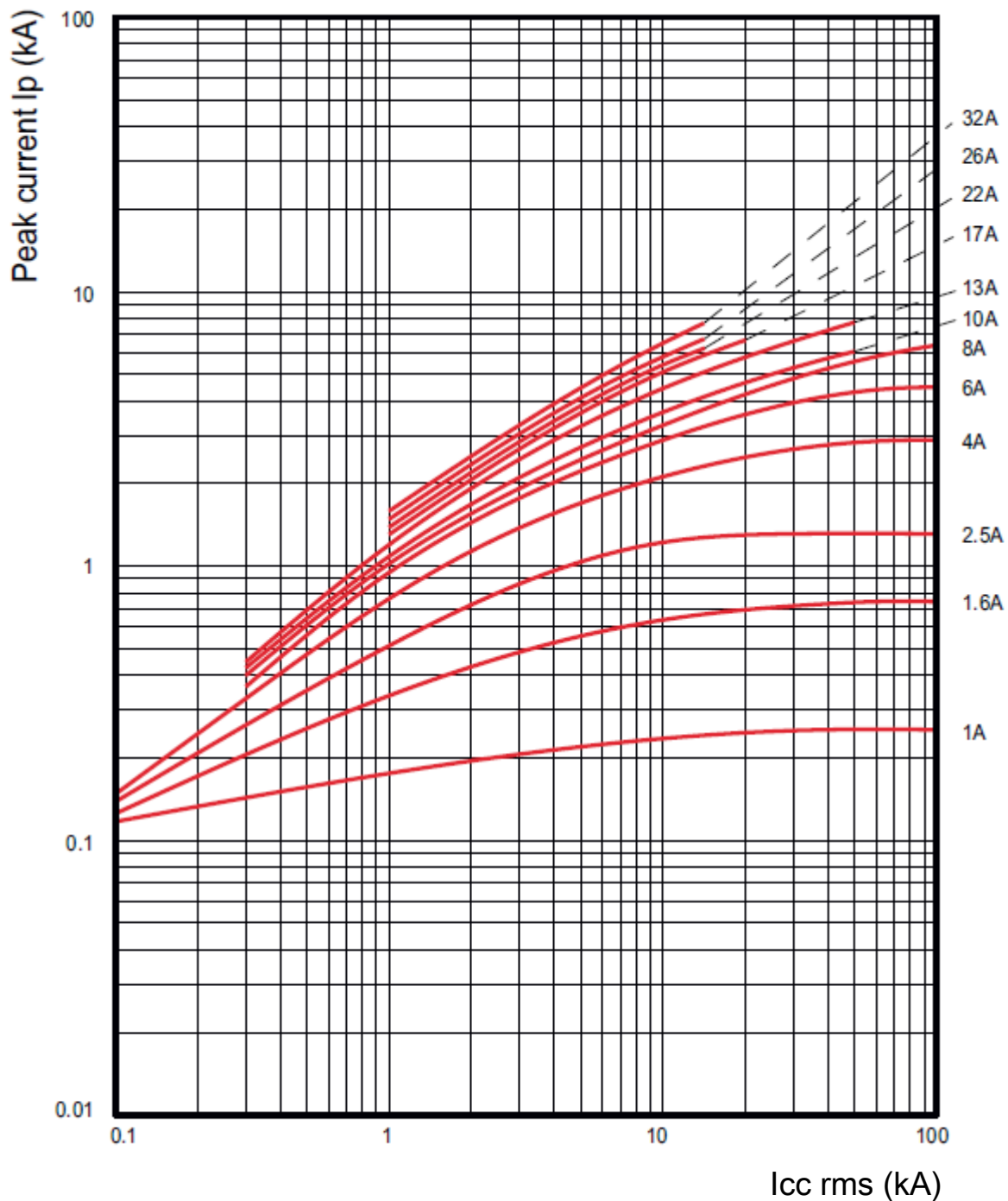

. Icc = Square value of symmetric component of the short circuit current (kA).

. Ip = Peak current (kA).

7. CURVES (continued)

Peak current in kA ($U_e = 415V$) :
. For MPX³ 32H / MPX³ 32MA

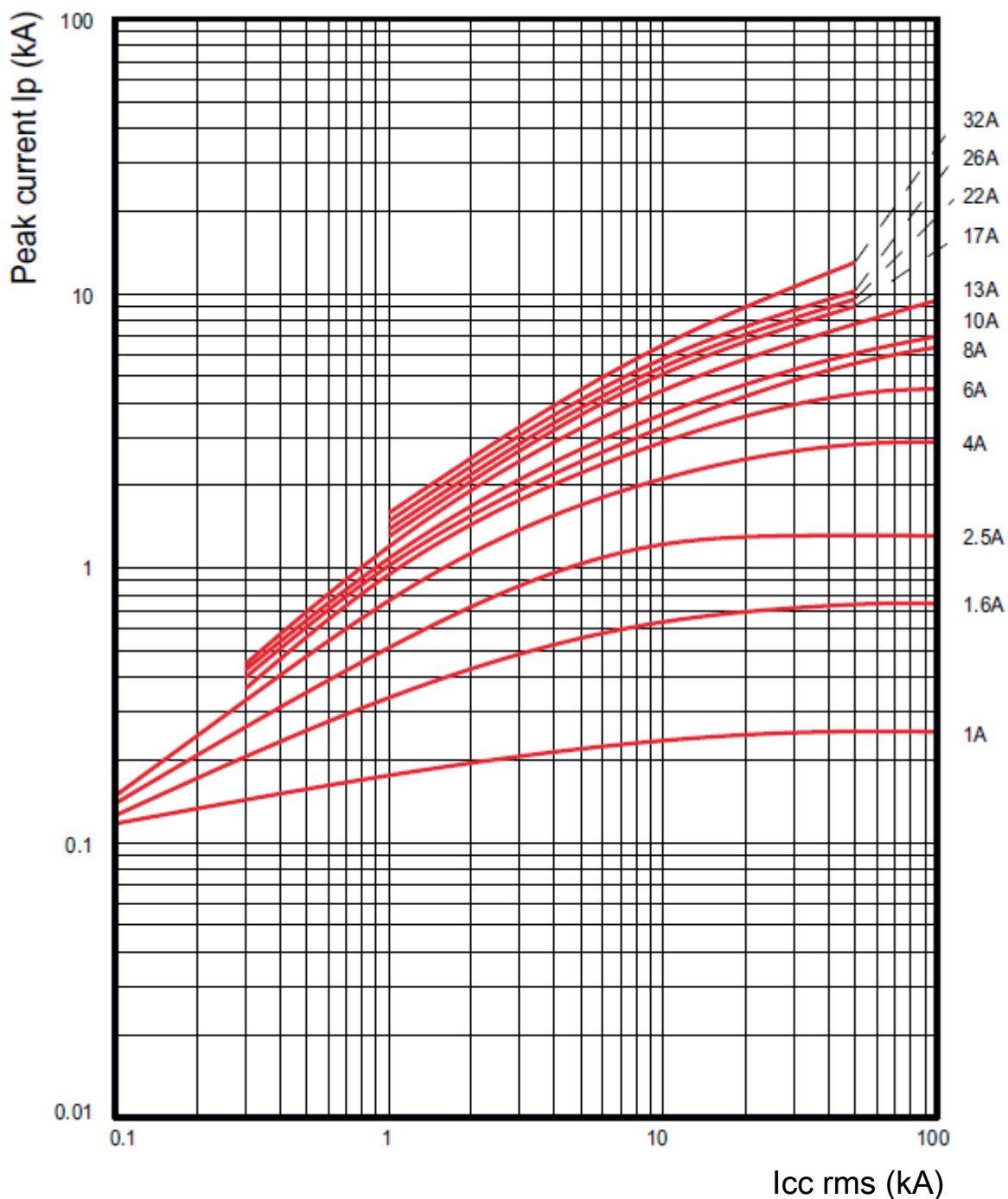

. I_{cc} = Square value of symmetric component of the short circuit current (kA).
. I_p = Peak current (kA).

7. CURVES (continued)

Peak current in kA (U_e = 415V) :

. For MPX³ 63H

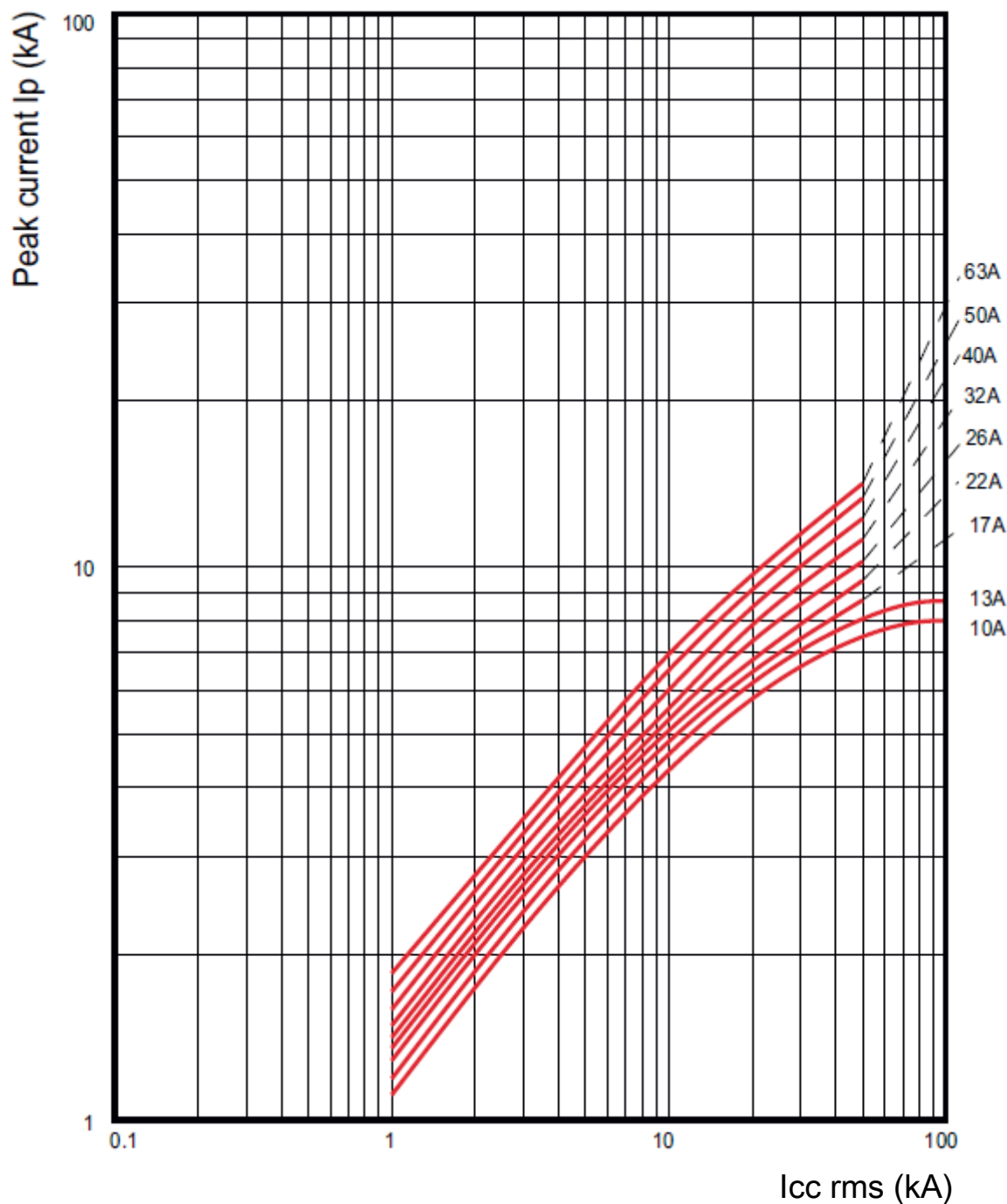

. I_{cc} = Square value of symmetric component of the short circuit current (kA).

. I_p = Peak current (kA).

7. CURVES (continued)

Peak current in kA ($U_e = 415V$) :

. For MPX³ 100H

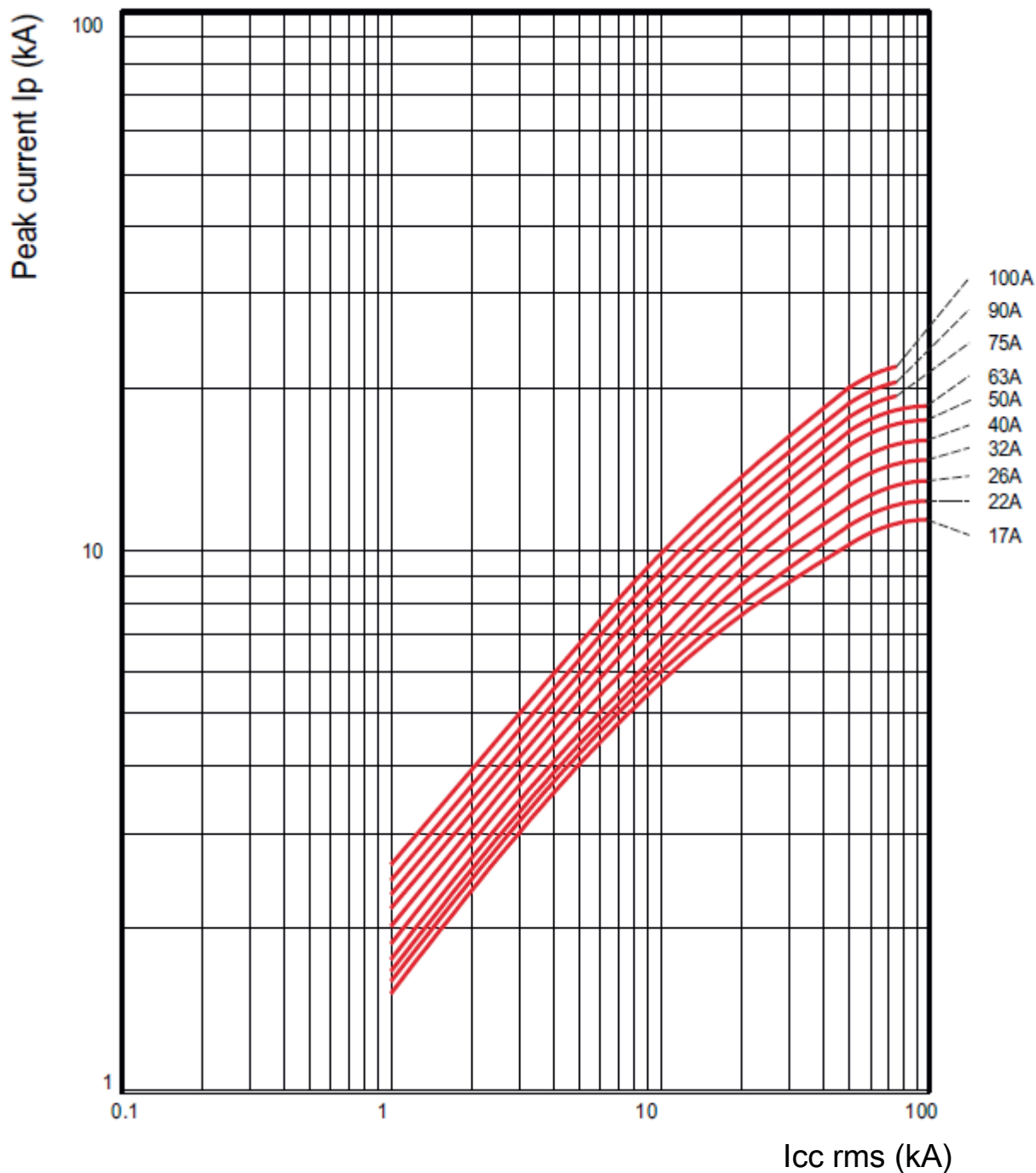

. Icc = Square value of symmetric component of the short circuit current (kA).

. Ip = Peak current (kA).

8. AUXILIARIES AND ACCESSORIES

Auxiliaries: (maximum 2 auxiliary switches per MPX³)

- . Auxiliary switch: (front mounting)
 - Auxiliary switch NO + NC (cat n° 4 174 03).

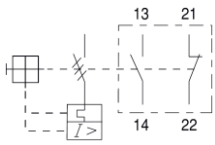

- Auxiliary switch 2NO (cat n° 4 174 04).

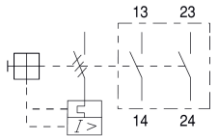

- Auxiliary switch 2NC (cat n° 4 174 05).

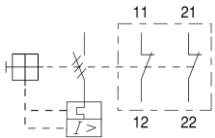

- . Auxiliary switch: (side mounting on the left)
 - Auxiliary switch NO + NC (cat n° 4 174 00).

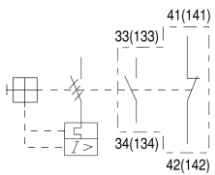

- Auxiliary switch 2NO (cat n° 4 174 01).

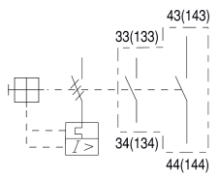

- Auxiliary switch 2NC (cat n° 4 174 02).

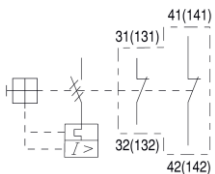

- . Any trip alarm switch: (side mounting on the left)
 - Any trip alarm switch NO + NC (cat n° 4 174 06).
 - Any trip alarm switch NO + NC 63/100A (cat n° 4 174 08).

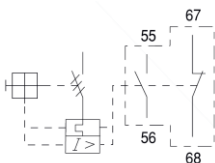

8. AUXILIARIES AND ACCESSORIES (continued)

Auxiliaries: (continued)

- . Magnetic trip alarm switch: (side mounting on the left)
 - Magnetic trip alarm switch NO + NC (cat n° 4 174 07).

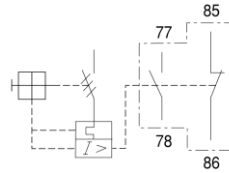

- . Shunt release: (side mounting on the right)
 - Shunt release 24V AC (cat n° 4 174 10).
 - Shunt release 110V AC (cat n° 4 174 11).
 - Shunt release 230V AC (cat n° 4 174 12).
 - Shunt release 400V AC (cat n° 4 174 13).

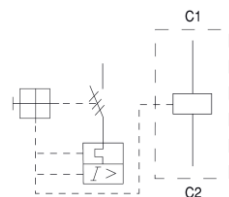

- . Undervoltage release: (side mounting on the right)
 - Undervoltage release 24V AC (cat n° 4 174 20).
 - Undervoltage release 110V AC (cat n° 4 174 21).
 - Undervoltage release 230V AC (cat n° 4 174 22).
 - Undervoltage release 400V AC (cat n° 4 174 23).

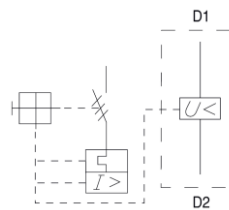

- . Undervoltage release with switch: (side mounting on the right)
 - Undervoltage release with switch 2NO 24V AC. (cat n° 4 174 30)
 - Undervoltage release with switch 2NO 110V AC. (cat n° 4 174 31)
 - Undervoltage release with switch 2NO 230V AC. (cat n° 4 174 32)
 - Undervoltage release with switch 2NO 400V AC. (cat n° 4 174 33)

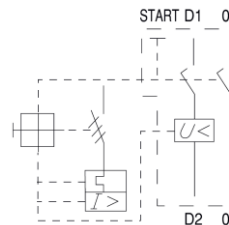

8. AUXILIARIES AND ACCESSORIES (continued)

Auxiliaries: (continued)

. Possible combinations of auxiliaries:

Auxiliaries			MPX ³ 32S		MPX ³ 32H / MA		MPX ³ 63H			MPX ³ 100H	
Auxiliary contacts	Front mounting	Max. No.	0	1 or	0	1 or	0	1 or	1	0	1 or
	Side mounting	Max. No.	2	1	2	1	2	1	0	2	1
Fault signal contact		Max. No.	0	1	0	1	0	1 ⁽¹⁾	1 ⁽²⁾	0	1 ⁽²⁾
Shunt trip or undervoltage release		Max. No.	1	1	1	1	1	1	1	1	1

(1) : cat n° 4 174 07

(2) : cat n° 4 174 08

General characteristics auxiliaries:

			Auxiliary contacts for front mounting		Auxiliary contacts for left side mounting		Alarm switch for left side mounting	
Rated thermal current / th								
at 40°C ambient temperature			[A] 5		10		10	
at 60°C ambient temperature			[A] 3		6		6	
Contact class coordination according to NEMA (UL/CSA-Standards)								
AC			A600		A600		A600	
DC			Q300		Q300		Q300	
Back-up fuses gG, gL			[A] 16		16		16	
Rated supply current			[V] -		24		24	
AC-15:			[A] -		6		4	
DC-13:			[V] 24		220		24	
			[A] 1		0.1		2	
					2		0.25	
Weight (g)			18		30		40	
Terminal parts								
Wire							Pozidriv size 2	
Single-core 1 conductor			[mm] / [AWG] 0.5...2.5 / 20...14		0.5...2.5 / 20...14		0.5...2.5 / 20...14	
2 conductor			[mm] / [AWG] -		-		0.5...2.5 / 20...14	
Stranded 1 conductor			[mm] / [AWG] 0.5...4 / 20...10		0.5...4 / 20...10		0.5...4 / 20...10	
2 conductor			[mm] / [AWG] 0.75...2.5 / 18...14		0.75...2.5 / 18...14		0.75...2.5 / 18...14	
Tightening torque			[Nm] / [lb-in] 0.8...1.2 / 7...10		0.8...1.2 / 7...10		0.8...1.2 / 7...10	

			Undervoltage release for right side mounting		Undervoltage release with 2 auxiliary contacts for right side mounting		Shunt release for right side mounting	
Actuating voltage								
Pull-in			0.7...1.1× Us		0.85...1.1× Us		0.85...1.1× Us	
Drop-out					0.7...0.35× Us		0.7...0.35× Us	
Rated control voltage								
min.:			24V 50Hz / 28V 60Hz		24V 50Hz / 28V 60Hz		24V 50Hz / 28V 60Hz	
max.:			415~440V 50Hz / 460~480V 60Hz		415~440V 50Hz / 460~480V 60Hz		415~440V 50Hz / 460~480V 60Hz	
Coil rating								
Pull-in			8.5VA, 6W		8.5VA, 6W		8.5VA, 6W	
Hold			3VA, 1.2W		3VA, 1.2W		3VA, 1.2W	
Opening time (ms)			-		20		20	
Weight (g)			18		30		40	
Terminal parts								
Wire							Pozidriv size 2	
Single-core 1 conductor			[mm] / [AWG] 0.5...2.5 / 20...14		0.5...2.5 / 20...14		0.5...2.5 / 20...14	
2 conductor			[mm] / [AWG] -		-		0.5...2.5 / 20...14	
Stranded 1 conductor			[mm] / [AWG] 0.5...4 / 20...10		0.5...4 / 20...10		0.5...4 / 20...10	
2 conductor			[mm] / [AWG] 0.75...2.5 / 18...14		0.75...2.5 / 18...14		0.75...2.5 / 18...14	
Tightening torque			[Nm] / [lb-in] 0.8...1.2 / 7...10		0.8...1.2 / 7...10		0.8...1.2 / 7...10	

8. AUXILIARIES AND ACCESSORIES (continued)

Auxiliaries: (continued)

. Direct connector and Mounting unit

Type		Combined devices	
Direct connector	Mounting Unit	MPX ³	CTX ³
4 174 40	Mounting Unit MPX ³ 32S / 32H / 32MA 4 174 60	MPX ³ 32S	CTX ³ mini AC
4 174 41			CTX ³ mini DC
4 174 48			CTX ³ 22 AC
4 174 49			CTX ³ 22 DC
4 174 52			CTX ³ 40 AC
4 174 53			CTX ³ 40 DC
4 174 42		MPX ³ 32H / 32MA	CTX ³ mini AC
4 174 43			CTX ³ mini DC
4 174 50			CTX ³ 22 AC
4 174 51			CTX ³ 22 DC
4 174 54			CTX ³ 40 AC
4 174 55	CTX ³ 40 DC		
4 174 56	Mounting Unit MPX ³ 63H 4 174 61	MPX ³ 63H	CTX ³ 65 AC
4 174 57			CTX ³ 65 DC
4 174 58	Mounting Unit MPX ³ 100H 4 174 62	MPX ³ 100H	CTX ³ 100 AC
4 174 59			CTX ³ 100 DC

. Installation principle:

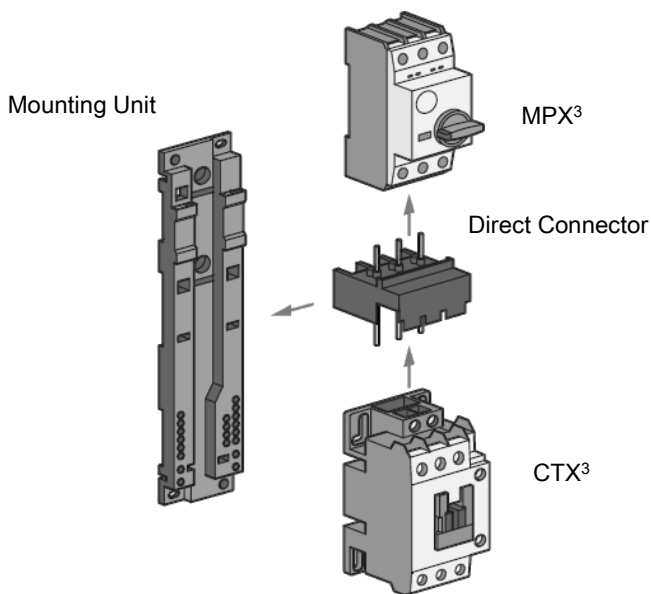

8. AUXILIARIES AND ACCESSORIES (continued)

Auxiliaries: (continued)

. Direct connector:



Overall dimensions Mounting unit:

. Mounting Unit MPX³ 32S / 32H / 32MA (cat n° 4 174 60)

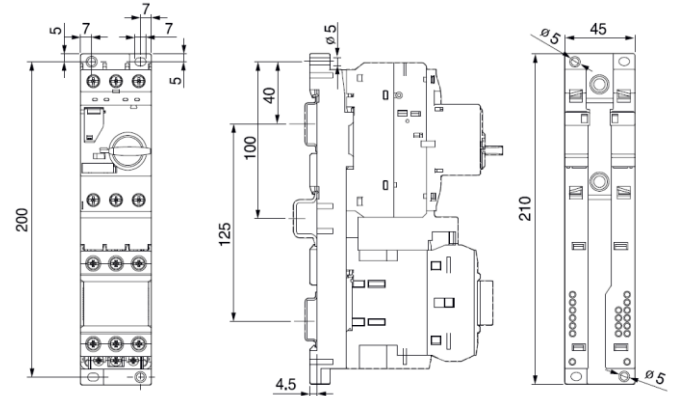

. Mounting Unit MPX³ 63H (cat n° 4 174 61)

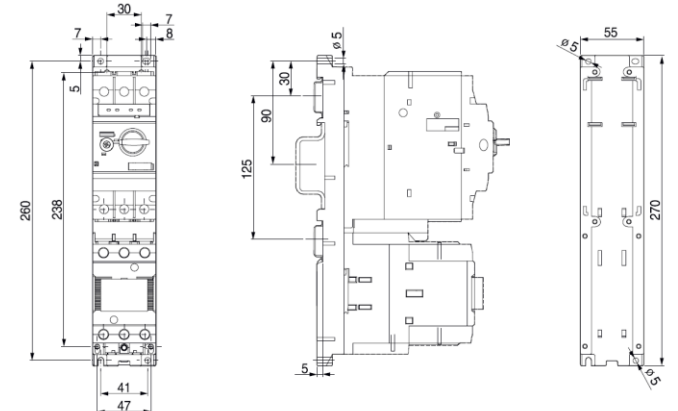

. Mounting Unit MPX³ 100H (cat n° 4 174 62)

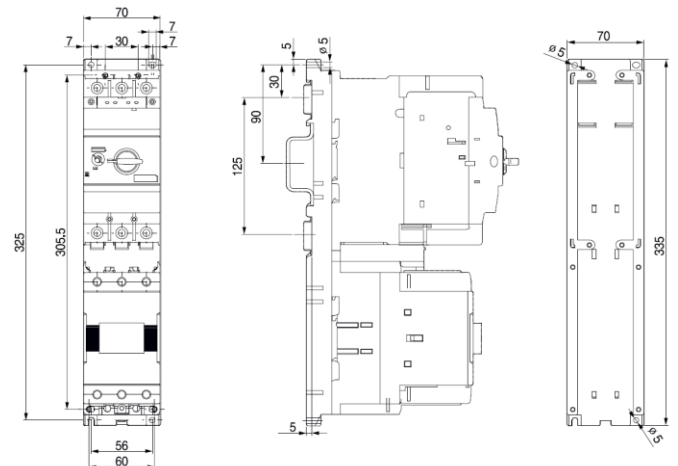

8. AUXILIARIES AND ACCESSORIES (continued)

Accessories: (continued)

. Dial Cover MPX³ (cat n° 4 174 79).

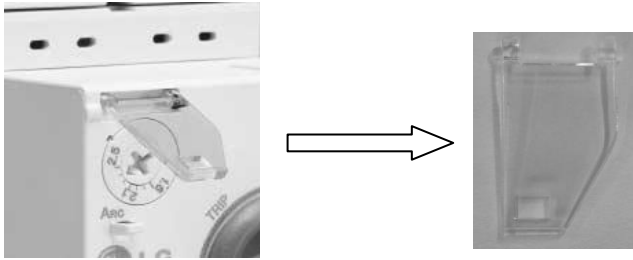

. Phase Busbar MPX³:

References	Application MPX ³	Number of breakers	Rated current
4 174 71	MPX ³ 32S / 32H / 32MA	2	63 [A]
4 174 73		3	
4 174 75		4	
4 174 76		5	
4 174 72	MPX ³ 63H	2	108 [A]
4 174 74		3	



. Feeder 32A phase busbar for MPX³ 32S / 32H / 32 MA (cat n° 4 174 77).

Pole	3P
Mounting location	Upstream
IP degree of protection	IP20 according to IEC 60 529
Rated insulation voltage (Ui)	690 [V] according to IEC 60 947-1
Rated operational current (Ie)	63 [A]
Terminal torque	1.7 [Nm] on screw clamp terminals

Installation software:

. XL PRO³.

8. AUXILIARIES AND ACCESSORIES (continued)

Accessories: (continued)

. Enclosure IP 65:

- Enclosure yellow red rotary handle MPX³ 32H / 32MA. (cat n° 4 174 80)
- Enclosure rotary handle MPX³ 32H / 32MA. (cat n° 4 174 81)



. Rotary handle:

- Rotary handle MPX³ 32H / 32MA (cat n° 4 174 63).
- Rotary handle MPX³ 63H (cat n° 4 174 64).
- Rotary handle MPX³ 100H (cat n° 4 174 65).



References	Application MPX ³	Shaft / Length
4 174 63	MPX ³ 32H / 32MA	315 [mm]
4 174 64	MPX ³ 63H	
4 174 65	MPX ³ 100H	

- . Operation temperature : Min. = -20°C. Max. = +60°C.
- . Degree of protection : IP65 or UL50 Type 3R (separately).
- . Locking device : Lockable in ON / OFF position.
- . Material of insulation : Plastic (PA66).