

# DPX<sup>3</sup> 160 thermal magnetic

MCCBs from 16 to 160 A



Electrical characteristics **see e-catalogue**  
Dimensions **see e-catalogue**

Can be mounted on rail or on plate in XL<sup>3</sup> cabinets and enclosures  
MCCBs for switching, control isolation and protection of low voltage electrical lines  
Supplied with fixing screws cage terminals 70 mm<sup>2</sup> max. (flexible cable) or 95 mm<sup>2</sup> max. rigid cable with accessories  
Can be fitted with DPX<sup>3</sup> 160 and 250 common auxiliaires and accessories (p. 134)  
Conform to IEC 60947-2

Pack	Cat.Nos		
			<b>MCCBs - fixed version</b>
			Thermal adjustable from 0,8 to 1 In Magnetic fixed at 10 In (fixed at 400 A for In 16 A and 25 A)
			<b>Breaking capacity Icu 16 kA (400 V~)</b>
	3P	4P	In (A)
1	4 200 00	4 200 10	16
1	4 200 01	4 200 11	25
1	4 200 02	4 200 12	40
1	4 200 03	4 200 13	63
1	4 200 04	4 200 14	80
1	4 200 05	4 200 15	100
1	4 200 06	4 200 16	125
1	4 200 07	4 200 17	160
			<b>Breaking capacity Icu 25 kA (400 V~)</b>
1	4 200 40	4 200 50	16
1	4 200 41	4 200 51	25
1	4 200 42	4 200 52	40
1	4 200 43	4 200 53	63
1	4 200 44	4 200 54	80
1	4 200 45	4 200 55	100
1	4 200 46	4 200 56	125
1	4 200 47	4 200 57	160
			<b>Breaking capacity Icu 36 kA (400 V~)</b>
1	4 200 80	4 200 90	16
1	4 200 81	4 200 91	25
1	4 200 82	4 200 92	40
1	4 200 83	4 200 93	63
1	4 200 84	4 200 94	80
1	4 200 85	4 200 95	100
1	4 200 86	4 200 96	125
1	4 200 87	4 200 97	160
			<b>Breaking capacity Icu 50 kA (400 V~)</b>
1	4 201 20	4 201 30	16
1	4 201 21	4 201 31	25
1	4 201 22	4 201 32	40
1	4 201 23	4 201 33	63
1	4 201 24	4 201 34	80
1	4 201 25	4 201 35	100
1	4 201 26	4 201 36	125
1	4 201 27	4 201 37	160











Pack	Cat.Nos		
			<b>MCCBs with electronic earth leakage module - fixed version</b>
			Thermal adjustable from 0,8 to 1 In Magnetic fixed at 10 In (fixed at 400 A for In 16 A and 25 A)
			Equipped with earth leakage module with LCD screen
			Adjustable sensitivity: 0.03 - 0.3 - 1 - 3 A
			Adjustable tripping: 0 - 0.3 - 1 - 3s (with 0.03 A possible only 0 s)
			<b>Breaking capacity Icu 16 kA (400 V~)</b>
			In (A)
			4P
1	4 200 30		16
1	4 200 31		25
1	4 200 32		40
1	4 200 33		63
1	4 200 34		80
1	4 200 35		100
1	4 200 36		125
1	4 200 37		160
			<b>Breaking capacity Icu 25 kA (400 V~)</b>
1	4 200 70		16
1	4 200 71		25
1	4 200 72		40
1	4 200 73		63
1	4 200 74		80
1	4 200 75		100
1	4 200 76		125
1	4 200 77		160
			<b>Breaking capacity Icu 36 kA (400 V~)</b>
1	4 201 10		16
1	4 201 11		25
1	4 201 12		40
1	4 201 13		63
1	4 201 14		80
1	4 201 15		100
1	4 201 16		125
1	4 201 17		160
			<b>Breaking capacity Icu 50 kA (400 V~)</b>
1	4 201 50		16
1	4 201 51		25
1	4 201 52		40
1	4 201 53		63
1	4 201 54		80
1	4 201 55		100
1	4 201 56		125
1	4 201 57		160

See the video



DPX<sup>3</sup>

electrical characteristics

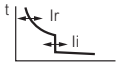
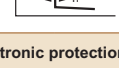
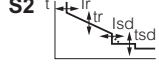
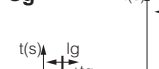
																																																								
DEVICES	DPX <sup>3</sup> 160 thermal magnetic				DPX <sup>3</sup> 250 thermal magnetic				DPX <sup>3</sup> 250 electronic release				DPX <sup>3</sup> 630 thermal magnetic				DPX <sup>3</sup> 630 electronic release				DPX <sup>3</sup> 1600 thermal magnetic				DPX <sup>3</sup> 1600 electronic release																															
Mounting	On rail  or on plate								On rail  or on plate								On rail  or on plate								On plate								On plate								On plate								On plate							
Breaking capacity (kA) (EN 60947-2 and IEC 60947-2)	16 kA	25 kA	36 kA	50 kA	25 kA	36 kA	50 kA	70 kA	25 kA	36 kA	50 kA	70 kA		36 kA	50 kA	70 kA	100 kA	36 kA	50 kA	70 kA	100 kA	36 kA	50 kA	70 kA	100 kA	36 kA	50 kA	70 kA	100 kA	36 kA	50 kA	70 kA	100 kA																							
380/415 V~	16	25	36	50	25	36	50	70	25	36	50	70		36	50	70	100	36	50	70	100	36	50	70	100	36	50	70	100	36	50	70	100																							
220/240 V~	25	35	50	65	40	60	100	100	40	60	100	100		70	100	120	170	70	100	120	170	70	100	120	170	70	100	120	170	70	100	120	170																							
Breaking capacity (% Icu)	100	100	100	100	100	100	100	100	100	100	100	100		100	100	100	100	100	100	100	100	100	100	100	100	100	100	100	100	100	100	100																								
Characteristic of use																																																								
Nominal frequency	50/60 Hz												50/60 Hz																																											
Maximum rated operating voltage Ue	690 V (500 V with integrated e.l.c.bs)				690 V (500 V with integrated e.l.c.bs)				690 V (500 V with integrated e.l.c.bs)				690 V~				690 V~				690 V~				690 V~																															
Category of use	A				A				A				A				A: In 630 A - B: In 200 to 400 A				A				B																															
Thermal magnetic adjustment																																																								
 Thermal	0,8 to 1 In				0,8 to 1 In				-				0.8 to 1 In				-				0.8 to 1 In				-																															
 Magnetic	10 In (400 A for 16 A and 25 A sizes)				5 to 10 In				-				5 to 10 In				-				5 to 10 In				-																															
Electronic protection adjustment																																																								
 S2																																																								
 Sg													Ir : 0,4 to 1 In I <sub>sd</sub> : 1,5 to 10 Ir																																											
																	S2				Sg																																			
																	Ir = 0.4 - 1 x In				•				•				Ir = 0.4 - 1 x In				•				•																			
																	Ir = 3-30 s				•				•				Ir = 3-30 s				•				•																			
																	I <sub>sd</sub> = 1.5 - 10 Ir				•				•				I <sub>sd</sub> = 1.5 - 10 Ir				•				•																			
																	tsd (I=K) = 0-500 ms				•				•				tsd (I=K) = 0-500 ms				•				•																			
																	tsd (I=K) = 0-500 ms				•				•				tsd (I=K) = 0-500 ms				•				•																			
																	I <sub>g</sub> = 0.2 - 1 x In				•				•				I <sub>g</sub> = 0.2 - 1 x In				•				•																			
																	t <sub>g</sub> = 0.1 - 1 s				•				•				t <sub>g</sub> = 0.1 - 1 s				•				•																			
Maximum cable cross-section																																																								
Rigid cable	150 mm <sup>2</sup>				150 mm <sup>2</sup>				150 mm <sup>2</sup>				300 mm <sup>2</sup> or 2 x 240 mm <sup>2</sup>				300 mm <sup>2</sup> or 2 x 240 mm <sup>2</sup>				2 or 4 x 240 mm <sup>2</sup>				2 or 4 x 240 mm <sup>2</sup>																															
Flexible cable	120 mm <sup>2</sup>				120 mm <sup>2</sup>				120 mm <sup>2</sup>				240 mm <sup>2</sup> or 2 x 185 mm <sup>2</sup>				240 mm <sup>2</sup> or 2 x 185 mm <sup>2</sup>				2 or 4 x 185 mm <sup>2</sup>				2 or 4 x 185 mm <sup>2</sup>																															
Copper bar and lug width	18 mm				28.5 mm <sup>(1)</sup>				28.5 mm <sup>(1)</sup>				32 mm				32 mm				50 mm				50 mm																															
Tightening torque	8 Nm				10 Nm				10 Nm				15 Nm				15 Nm				20 Nm				20 Nm																															
Nominal current (In) at 40 °C (A)																																																								
In (A)	16	25	40	63	80	100	125	160	100	160	200	250	40	100	160	250		250	320	400	500	630	250	320	400	500	630	500	630	800	1000	1250	500	630	800	1000	1250	1600																		
Phase	16	25	40	63	80	100	125	160	100	160	200	250	40	100	160	250		250	320	400	500	630	250	320	400	500	630	500	630	800	1000	1250	500	630	800	1000	1250	1600																		
N	16	25	40	63	80	100	125	160	100	160	200	250	40	100	160	250		250	320	400	500	630	0 - 50 - 100 % of phase value				500	630	800	1000	1250	0 - 50 - 100 % of phase value																								
N/2	-	-	-	-	-	-	-	-	-	-	-	-	-	-	-	-		-	250	250	250	320	-				-	-	-	500	630	-																								
Magnetic threshold (Im) (A) <sup>(2)</sup> of DPX <sup>3</sup> thermal magnetic																																																								
	Fixed								Adjustable								Adjustable								Adjustable																															
In (A)	16	25	40	63	80	100	125	160	100	160	200	250	-	250	320	400	500	630	-	500	630	800	1000	1250	-	500	630	800	1000	1250	-	-	-	-	-																					
Phase	400	400	400	630	800	1000	1250	1600	125-250	200-400	315-630	500-1000	-	1250-2500	1600-3200	2000-4000	2500-5000	3150-6300	-	2500-5000	3150-6300	4000-8000	5000-10000	6250-12500	-	2500-5000	3150-6300	4000-8000	5000-10000	6250-12500	-	-	-	-	-																					
N	400	400	400	630	800	1000	1250	1600	125-250	200-400	315-630	500-1000	-	1250-2500	1600-3200	2000-4000	2500-5000	3150-6300	-	2500-5000	3150-6300	4000-8000	5000-10000	6250-12500	-	2500-5000	3150-6300	4000-8000	5000-10000	6250-12500	-	-	-	-	-																					
N/2	-	-	-	-	-	-	-	-	-	-	-	-	-	-	1000-2000	1250-2500	1600-2500	2000-4000	-	-	-	-	2500-5000	3150-6000	-	-	-	-	2500-5000	3150-6000	-	-	-	-	-																					
Endurance (cycles)																																																								
Electrical	8000				8000				8000				5000				5000				4000				4000																															
Mechanical	25000				20000				20000				10000				20000				10000				10000																															
Electronic earth leakage module																																																								
Type	without or integrated				without or integrated				without or integrated				downstream e.l.c.bs.				downstream e.l.c.bs.				-				-																															

1: Copper bars only  
2: Trip current for 50/60 Hz. For direct current, multiply by 1.5

 For DPX<sup>3</sup> magnetic release only, Please, consult us

# DPX<sup>3</sup> 160 + earth leakage DPX<sup>3</sup>-I 160 + earth leakage

Reference(s) : 420 030/ 031/ 032/033/ 034/ 035/ 036/ 037/ 070/ 071/  
072/ 073/ 074/ 075/ 076/ 077/ 110/ 111/ 112/ 113/ 114/ 115/ 116/ 117/  
150/ 151/ 152/ 153/ 154/ 155/ 156/ 157/ 197

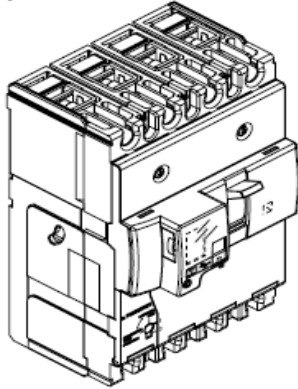

CONTENTS	PAGES
1. USE	1
2. RANGE	1
3. DIMENSIONS	1
3. DIMENSIONS (NEXT)	2
4. ELECTRICAL AND MECHANICAL CHARACTERISTICS	3
5. NAVIGATION	4
6. CONFORMITY	4
7. MARKING	4
8. EQUIPMENTS AND ACCESSORIES	5
9. CURVES	6

## 1. USE

DPX<sup>3</sup> "moulded case" offers optimal solutions to answer protection requirements of tertiary and industrial installations.

## 2. RANGE

DPX<sup>3</sup>

In (A)	16 kA 4P	25 kA 4P	36 kA 4P	50 kA 4P
16	420 030	420 070	420 110	420 150
25	420 031	420 071	420 111	420 151
40	420 032	420 072	420 112	420 152
63	420 033	420 073	420 113	420 153
80	420 034	420 074	420 114	420 154
100	420 035	420 075	420 115	420 155
125	420 036	420 076	420 116	420 156
160	420 037	420 077	420 117	420 157

DPX<sup>3</sup>-I

	4P
160	420 197

## 3. DIMENSIONS

### 3.1 Fixed version

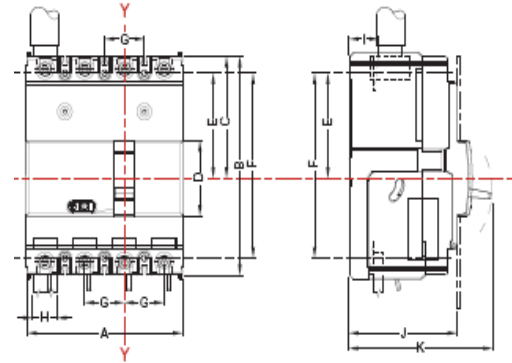
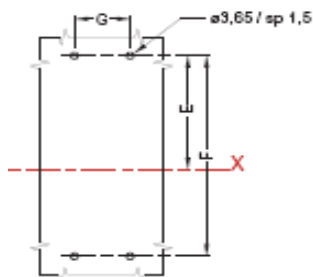

	A	B	C	D	E	F	G	H	I	J	K
160 DIFF	108	160	72,5	45	62,5	140	27	19	18	74	97

### 3.2 Fixed version, front terminals

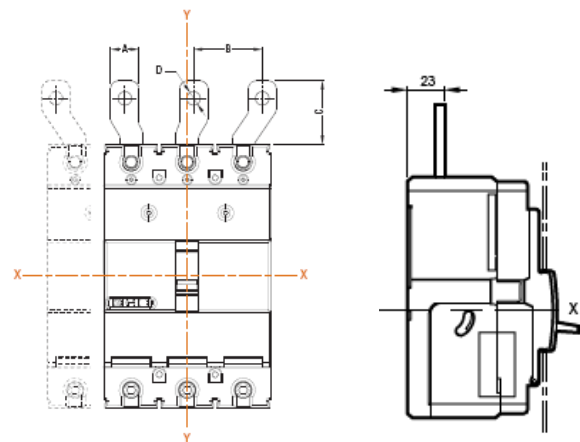

	A	B	C	D
160	17,5	35	41	8,5

# DPX<sup>3</sup> 160 + earth leakage DPX<sup>3</sup>-I 160 + earth leakage

Reference(s) : 420 030/ 031/ 032/033/ 034/ 035/ 036/ 037/ 070/ 071/  
072/ 073/ 074/ 075/ 076/ 077/ 110/ 111/ 112/ 113/ 114/ 115/ 116/ 117/  
150/ 151/ 152/ 153/ 154/ 155/ 156/ 157/ 197

### 3.3 Fixed version, rear terminals

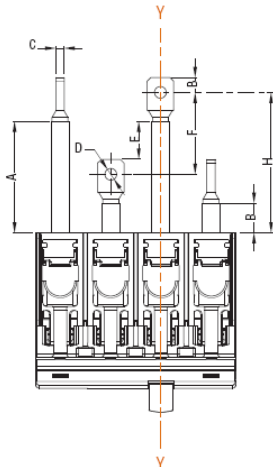

	A	B	C	D	E	F	G	H
<b>160</b>	65,5	21,5	4,5	6,3	19,5	44	11	79

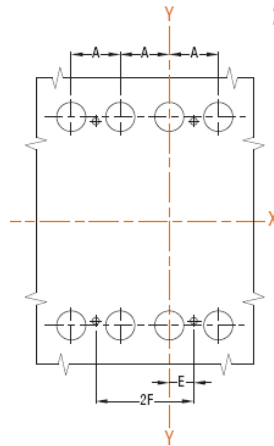

	A	B	C	D	E	F	G	H	I
<b>160 DIFF</b>	27	145	3,65	16	13,5	27	62,5	140	65

### 3.4 Fixed version, front motor operator

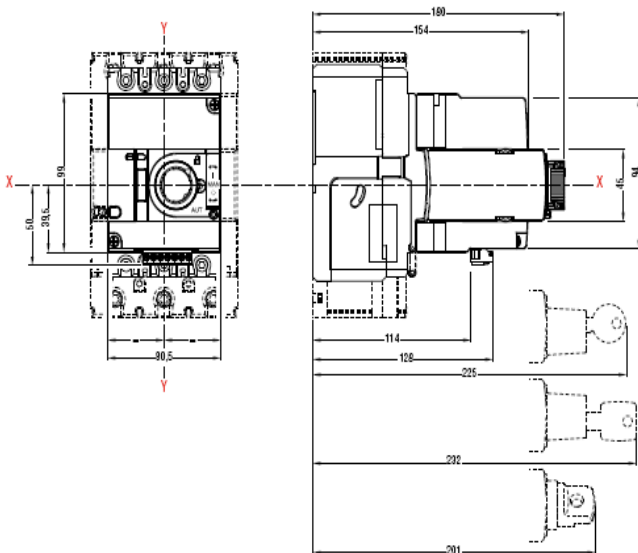

### 3.5 Fixed version, side motor operator

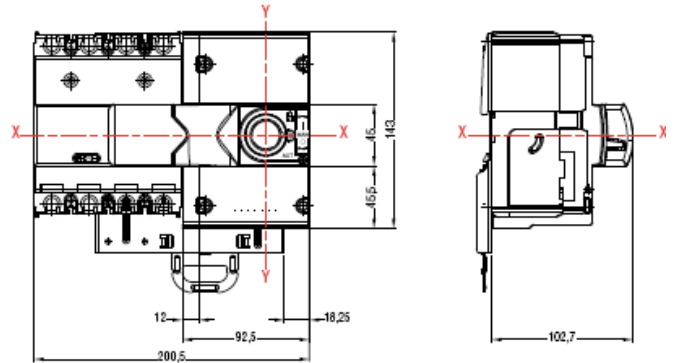

### 3.6 Plug-in version

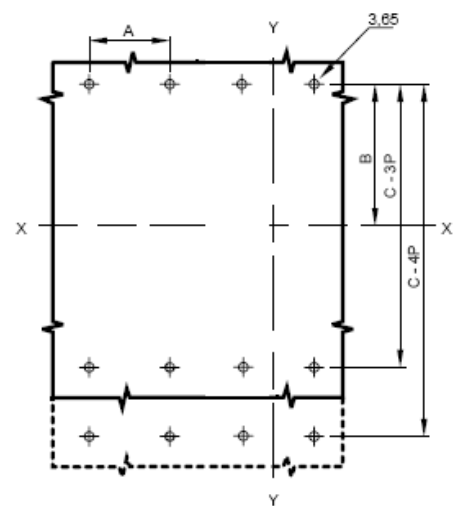
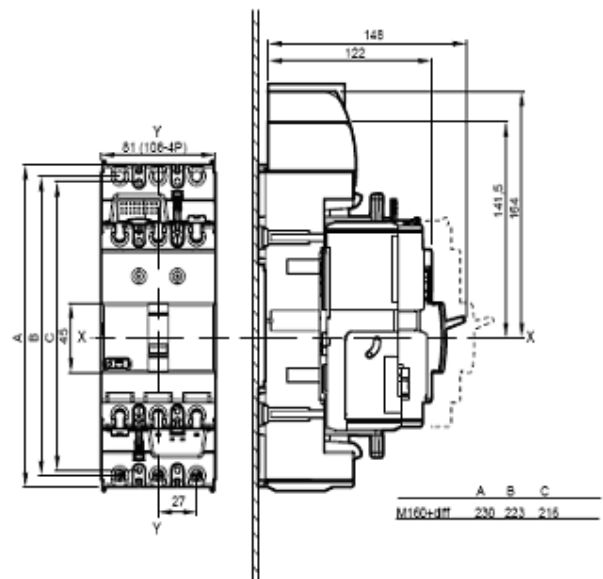

	A	B	C
<b>DPX<sup>3</sup> 160 + earth leakage</b>	27	100,5	216

# DPX<sup>3</sup> 160 + earth leakage DPX<sup>3</sup>-I 160 + earth leakage

Reference(s) : 420 030/ 031/ 032/033/ 034/ 035/ 036/ 037/ 070/ 071/  
072/ 073/ 074/ 075/ 076/ 077/ 110/ 111/ 112/ 113/ 114/ 115/ 116/ 117/  
150/ 151/ 152/ 153/ 154/ 155/ 156/ 157/ 197

## 4. ELECTRICAL AND MECHANICAL CHARACTERISTICS

### 4.1 Breaker technical characteristics

Circuit breaker	DPX <sup>3</sup> 160 + earth leakage
Rated current I <sub>n</sub> (A)	16-160
Rated insulation voltage U <sub>i</sub> (V)	600
Rated operational voltage U <sub>e</sub> (V)	500 V (ac) 500 V (dc)
Rated impulse withstand volt. U <sub>imp</sub> (kV)	6
Ambient temperature (°C)	40
Endurance electrical / mechanical	8000/10000
Utilization category	A
Releases type	thermal-mag + earth leakage
Nominal frequency (Hz)	50-60
Thermal adjustment	0,8 ÷ 1 I <sub>n</sub>
Magnetic threshold (for 16 and 25A I <sub>m</sub> = 400A)	10 x I <sub>n</sub>

### 4.2 Switches technical characteristics

Switches	DPX <sup>3</sup> -I 160
Rated current I <sub>n</sub> (A)	160
Rated insulation voltage U <sub>i</sub> (V)	800
Rated operational voltage U <sub>e</sub> (V)	690 V (ac) 500 V (dc)
Rated impulse withstand voltage U <sub>imp</sub> (kV)	8
Ambient temperature (°C)	40
Endurance electrical / mechanical	8000/25000
Nominal frequency (Hz)	50-60
Rated short-time withstand current I <sub>cw</sub> (1 s) (kA)	1,7
Rated short-circuit making capacity I <sub>cm</sub> (kA)	2,4
AC 22, AC 23, DC 22, DC 23 (A)	160

### 4.3 Breaking capacity (kA)

Breaking capacity I <sub>cu</sub> and I <sub>cs</sub> in AC (kA)					
	U <sub>e</sub>	16 kA	25 kA	36 kA	50 kA
I <sub>cu</sub> (kA)	220/240V	25	36	50	65
	380/415V	16	25	36	50
	440V	10	18	25	30
	460V	10	18	25	30
	480/500V	8	10	12	15
I <sub>cs</sub> (%I <sub>cu</sub> )	-	100	100	100	100
Rated short-circuit making capacity I <sub>cm</sub> (kA)					
	U <sub>e</sub>	16 kA	25 kA	36 kA	50 kA
I <sub>cm</sub> (kA)	415 V	32	52.5	75.6	105

### 4.4 Derating temperature Ta (°C)

Influence of ambient temperature Ta(°C)												
I <sub>n</sub> (A)	-25	-20	-10	-5	0	10	20	30	40	50	60	70
16	22	21	20	20	20	19	18	16	16	15	14	13
25	34	33	32	31	31	30	28	25	25	24	22	21
40	54	53	51	50	49	48	45	41	40	38	36	34
63	85	83	81	79	78	76	71	65	63	60	58	55
80	108	106	102	100	99	96	90	85	80	76	72	67
100	135	132	128	126	123	120	112	102	100	97	94	90
125	169	165	160	157	154	150	140	127	125	118	112	105
160	216	211	205	201	197	192	179	168	160	154	145	139

### 4.5 Breaker power loss (W)

#### 4.5.1 Breaker power loss (W)

Power loss DPX <sup>3</sup> 160 + earth leakage (W)								
I <sub>n</sub> (A) ---->	16	25	40	63	80	100	125	160
Cage terminals	2,8	5	5,1	6,7	7	11	12,5	15,4
Lugs	2,8	5	5,1	6,7	7	11	12,5	15,4
External terminals	2,8	5	5,1	6,7	7	11	12,5	15,4
Spreaders	2,8	5	5,1	6,7	7	11	12,5	15,4
Rear terminals	2,8	5	5,1	6,7	7	11	12,5	15,4
Plugin version	2,9	5,1	5,4	7,5	8,3	13	15,6	20,5

#### 4.5.2 Switches power loss (W)

Power loss DPX <sup>3</sup> -I 160 (W)	
I <sub>n</sub> (A) ---->	160
Cage terminals	9,2
Lugs	9,2
External terminals	9,2
Spreaders	9,2
Rear terminals	9,2
Plugin version	14,3

# DPX<sup>3</sup> 160 + earth leakage DPX<sup>3</sup>-I 160 + earth leakage

Reference(s) : 420 030/ 031/ 032/033/ 034/ 035/ 036/ 037/ 070/ 071/  
072/ 073/ 074/ 075/ 076/ 077/ 110/ 111/ 112/ 113/ 114/ 115/ 116/ 117/  
150/ 151/ 152/ 153/ 154/ 155/ 156/ 157/ 197

## 4.6 Short-circuit breaking capacity in D.C. current

Short-circuit breaking capacity in D.C. current				
Breaking capacity I <sub>cu</sub> (kA)				
	2 p. in ser.	2 p. in ser.	3 p. in ser.	3 p. in ser.
	110-125V	250V	400V	500V
160 16kA	32	16	16	10
160 25kA	50	25	25	20
160 36kA	60	30	30	25
160 50kA	80	40	40	35

\* Earth leakage protection not available

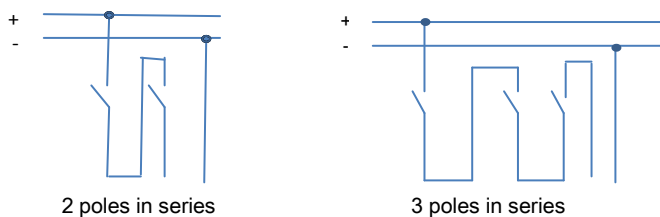

## 4.7 Protection in DC

Protection in D.C. current		
	thermal	magnetic
160 16 kA	like AC	1,5 I <sub>m</sub> AC
160 25 kA	like AC	1,5 I <sub>m</sub> AC
160 36 kA	like AC	1,5 I <sub>m</sub> AC
160 50 kA	like AC	1,5 I <sub>m</sub> AC

## 4.8 Altitude

Altitude (m)				
	Altitude (m)	≤2000	3000	4000
DPX <sup>3</sup> 160	Rated current (A)	1 x I <sub>n</sub>	0,96 x I <sub>n</sub>	0,93 x I <sub>n</sub>
	Rated voltage (V)	500	500	400

## 4.9 Loads operation

Loads operation	
Rated current (A)	I <sub>n</sub> =160
Opening (N)	45
Closing (N)	78
Reset (N)	75

## 5. NAVIGATION

### Setup mode

Setting I<sub>Δn</sub>:

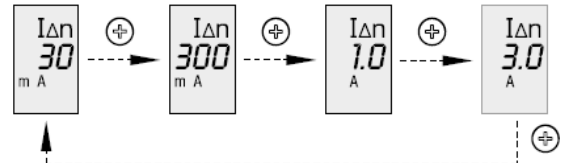

Setting t:



ATTENTION: after 5" of permanence on display of the new protection value I<sub>Δn</sub> or time Δt, it is automatically set.

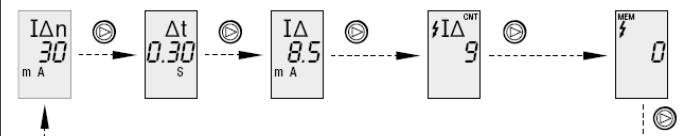

I<sub>Δn</sub> value      Δt value      I<sub>Δ</sub> measured      History of interventions  
set              set              value present      for differential intervention

## 6. CONFORMITY

IEC 60947-2  
(for switches IEC 60947-3)  
EN 60947-2  
(for switches EN 60947-3)

## 7. MARKING

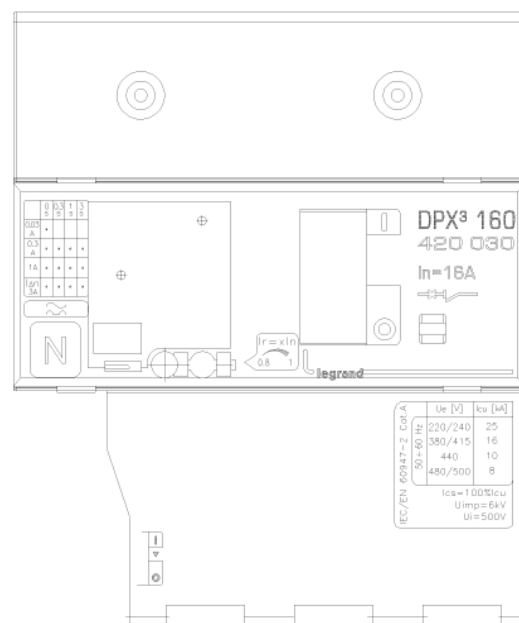



# DPX<sup>3</sup> 160 + earth leakage DPX<sup>3</sup>-I 160 + earth leakage

Reference(s) : 420 030/ 031/ 032/033/ 034/ 035/ 036/ 037/ 070/ 071/  
072/ 073/ 074/ 075/ 076/ 077/ 110/ 111/ 112/ 113/ 114/ 115/ 116/ 117/  
150/ 151/ 152/ 153/ 154/ 155/ 156/ 157/ 197

## 8. EQUIPMENTS AND ACCESSORIES

### 8.1 Releases

#### • Shunt releases with voltage:

12 Vac/dc	ref. 421 012
24 Vac/dc	ref. 421 013
48 Vac/dc	ref. 421 014
110-130 Vac	ref. 421 015
200-277 Vac	ref. 421 016
380-480 Vac	ref. 421 017

#### • undervoltage releases with voltage:

12 Vac/dc	ref. 421 018
24 Vac/dc	ref. 421 019
48 Vac/dc	ref. 421 020
110 Vac	ref. 421 021
200-240 Vac	ref. 421 022
277 Vac	ref. 421 023
380-415 Vac	ref. 421 024
440-480 Vac	ref. 421 025

#### • auxiliary contact:

set of connectors for aux contacts	ref. 421 044
aux contacts and fault signal	ref. 421 011
aux contacts (1NC and 1 NO) for all rotary handles	ref. 421 010
inserted device signal	ref. 421 048

### 8.2 Rotary handles :

#### Direct:

• DPX <sup>3</sup> direct rotary handle ele/RCD	ref. 421 001
• DPX <sup>3</sup> emergency direct rotary handle ele/RCD	ref. 421 003

#### Vari-depht:

• DPX <sup>3</sup> vari depth rotary handle	ref. 421 004
• DPX <sup>3</sup> emergency vari depth rotary handle	ref. 421 005

#### Locking accessories

• locking acc. for direct rotary handle - ronis	ref. 421 006
• locking acc. for direct rotary handle - profalux	ref. 421 007
• locking acc. for vari depth rotary handle - ronis	ref. 421 008
• locking acc. for vari depth rotary handle – profalux	ref. 421 009

### 8.3 Mechanical accessories :

#### Insulated shields

• Set of 3	ref. 421 070
------------	--------------

#### Sealable terminal shields

• sealable terminal shield for rear terminals 160 4P	ref. 421 051
• sealable terminal shield for front spreaders 160 4P	ref. 421 055

#### Padlocks

• DPX <sup>3</sup> padlock accessory for handle (off)	ref. 421 049
---	--------------

#### Interlock:

• DPX <sup>3</sup> interlock mounting plate	ref. 421 058
• DPX <sup>3</sup> interlock for plug-in / draw-out version	ref. 421 059

### 8.4 Connection's accessories :

#### Cage terminals

• High capacity terminals for al or cu cables kit (4) - flex 1x120mm <sup>2</sup> , rigid 1x150mm <sup>2</sup> , bar/cable lug 18mm	ref. 421 027
• rack screw and nut for cable lug (4)	ref. 421 029

#### Front spreaders

• DPX <sup>3</sup> front spreaders for 4P DPX <sup>3</sup> 160 (4)	ref. 421 033
--	--------------

#### Rear terminals

• DPX <sup>3</sup> flat rear terminals for 4P DPX <sup>3</sup> 160 (4)	ref. 421 037
--	--------------

### 8.5 Plug-in version

#### Bases

• front/rear terminals plug-in base 4P DPX <sup>3</sup> 160	ref. 421 041
---	--------------

#### Locking accessories

• locking accessory for plug-in base – ronis	ref. 421 045
• locking accessory for plug-in base – profalux	ref. 421 046
• padlock accessory for plug-in base	ref. 421 047

### 8.6 Motor operator

• side motor operator 24-230 Vac - 24-230 Vdc	ref. 421 060
• front motor operator 24-230 Vac - 24-230 Vdc	ref. 421 061

#### Locking accessories for front motor operator:

• locking acc. for front motor operator - ronis	ref. 421 062
• locking acc. for front motor operator – profalux	ref. 421 063
• padlock selector for front motor operator	ref. 421 064

#### Locking accessories for side motor operator:

• locking acc. for side motor operator - ronis	ref. 421 065
• locking acc. for side motor operator – profalux	ref. 421 066
• padlock selector for side motor operator	ref. 421 067

#### Din plate:

DPX <sup>3</sup> din plate for motor operator DPX <sup>3</sup> 160	ref. 421 068
--	--------------

### 8.7 Mounting on rail fixing plate

DPX <sup>3</sup> din rail fixing plate DPX <sup>3</sup> 160 4P+Earth Leakage	ref. 421 073
--	--------------

### 8.8 Supply

Lithium battery CR1616 3V x 2	ref. 421 082
-------------------------------	--------------

**DPX<sup>3</sup> 160 + earth leakage**  
**DPX<sup>3</sup>-I 160 + earth leakage**

Reference(s) : 420 030/ 031/ 032/033/ 034/ 035/ 036/ 037/ 070/ 071/  
 072/ 073/ 074/ 075/ 076/ 077/ 110/ 111/ 112/ 113/ 114/ 115/ 116/ 117/  
 150/ 151/ 152/ 153/ 154/ 155/ 156/ 157/ 197

**9. CURVES**

**9.1 TRIPPING CURVE**

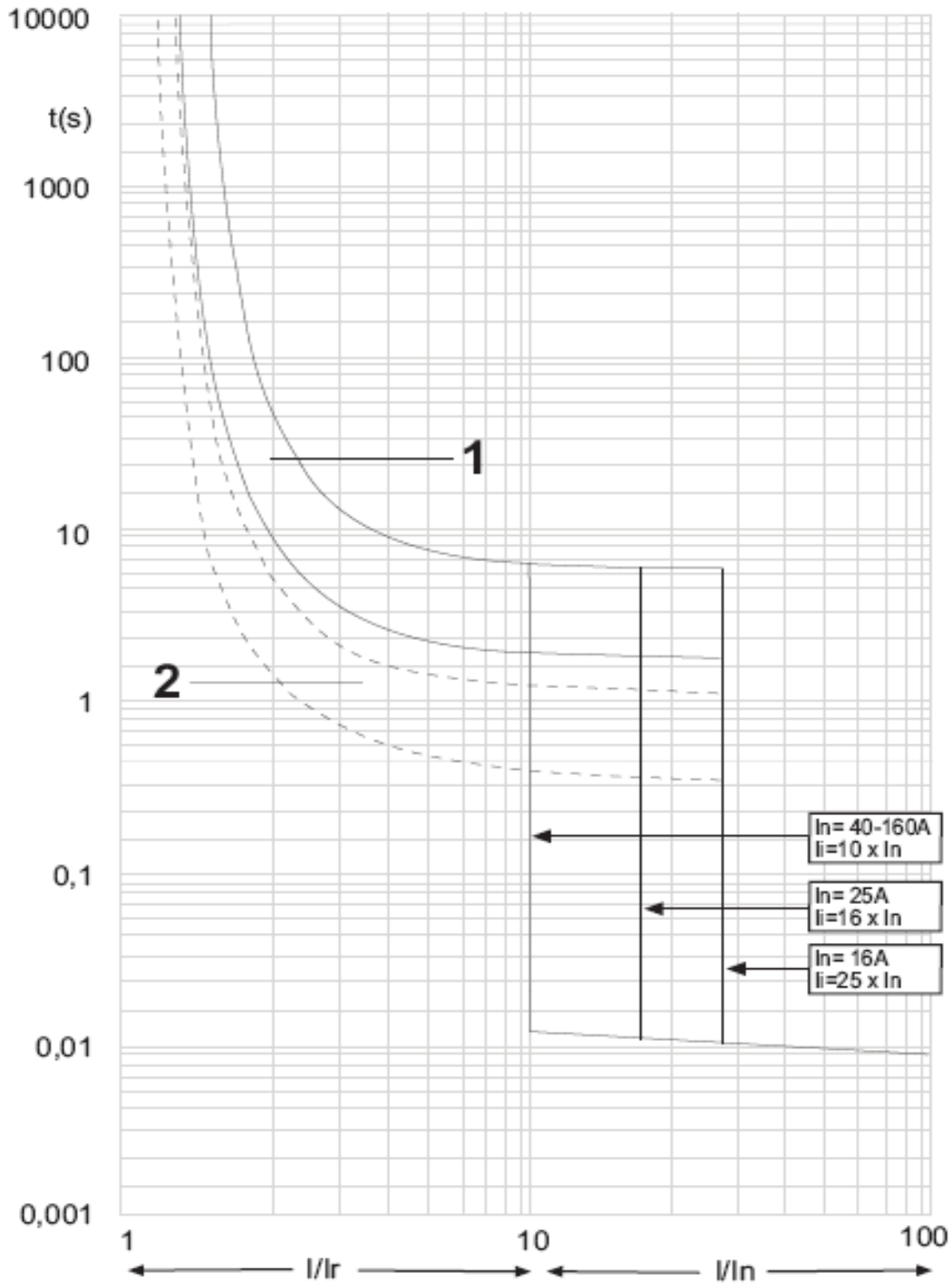

$t$  = time  
 $I$  = rated current  
 $I_r$  = setting current  
 curve number 1 = characteristic with cold start  
 curve number 2 = characteristic with hot start



# DPX<sup>3</sup> 160 + earth leakage

## DPX<sup>3</sup>-I 160 + earth leakage

Reference(s) : 420 030/ 031/ 032/033/ 034/ 035/ 036/ 037/ 070/ 071/  
072/ 073/ 074/ 075/ 076/ 077/ 110/ 111/ 112/ 113/ 114/ 115/ 116/ 117/  
150/ 151/ 152/ 153/ 154/ 155/ 156/ 157/ 197

### 9.2 Energy curve

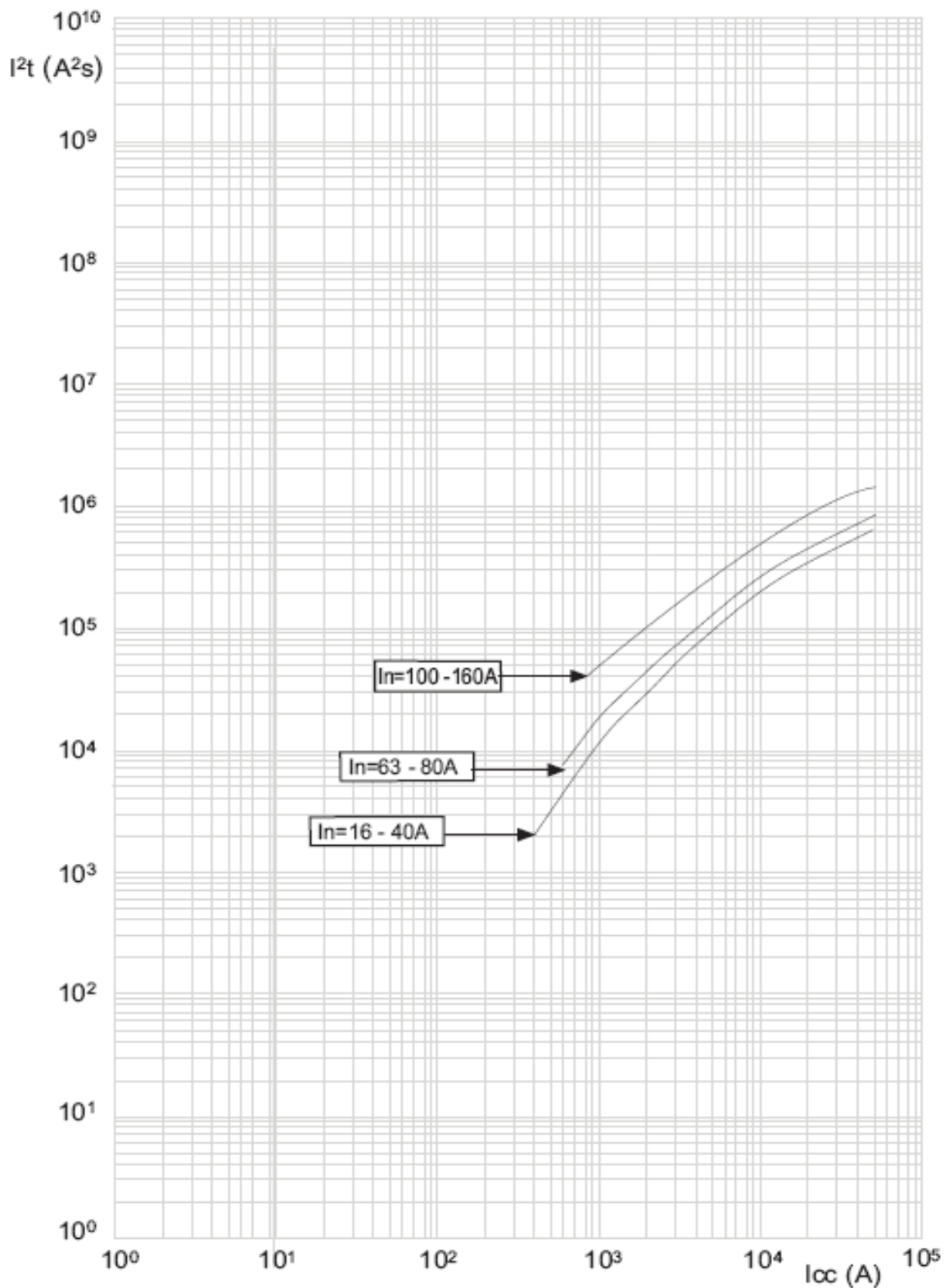

$I_{cc}$  = estimated short circuit symmetrical current (RMS value)  
 $I^2t$  (A<sup>2</sup>s) = pass-through specific energy

**DPX<sup>3</sup> 160 + earth leakage**  
**DPX<sup>3</sup>-I 160 + earth leakage**

Reference(s) : 420 030/ 031/ 032/033/ 034/ 035/ 036/ 037/ 070/ 071/  
 072/ 073/ 074/ 075/ 076/ 077/ 110/ 111/ 112/ 113/ 114/ 115/ 116/ 117/  
 150/ 151/ 152/ 153/ 154/ 155/ 156/ 157/ 197

**9.3 Restricted current curve**

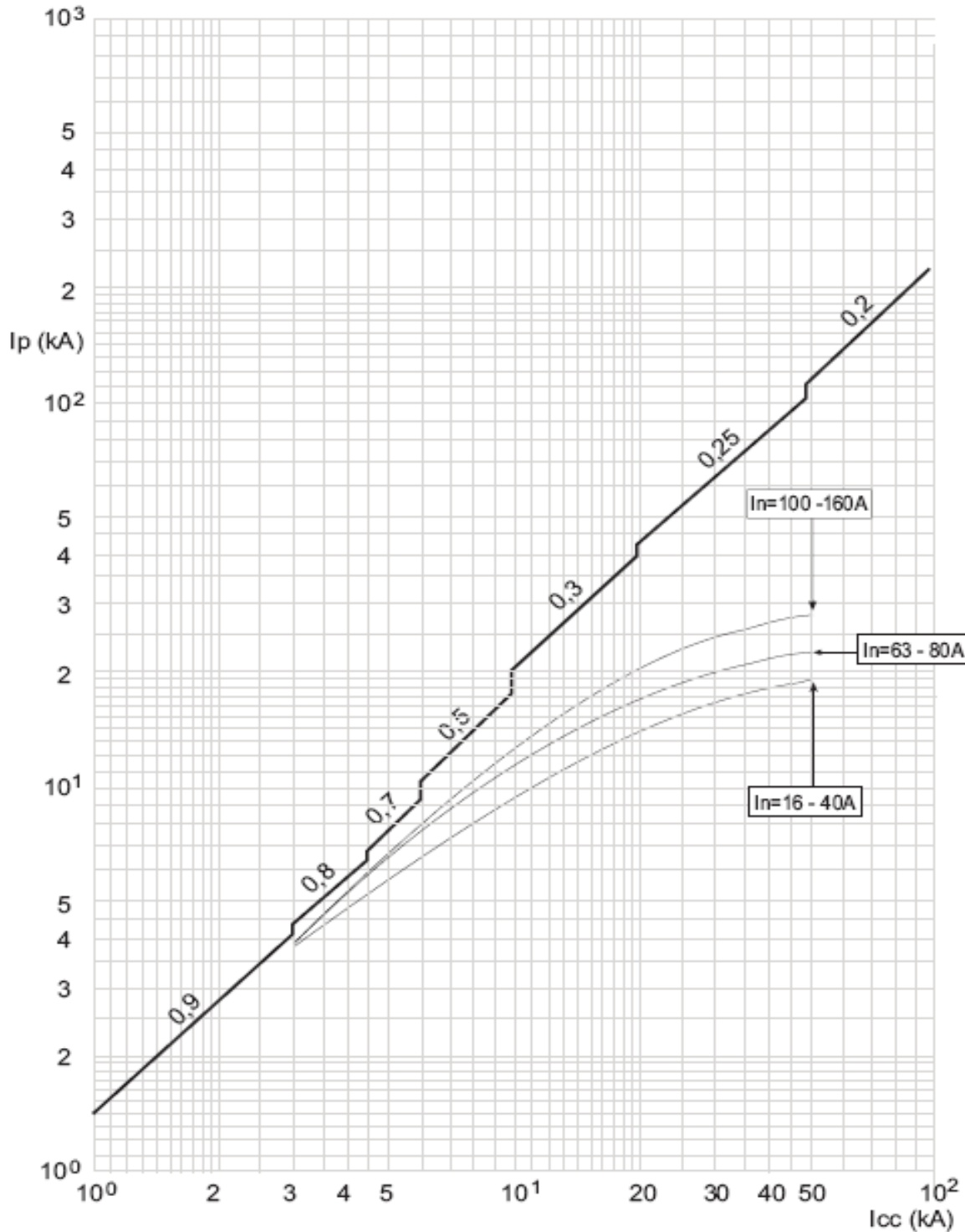

$I_{cc}$  = estimated short circuit symmetrical current (RMS value)  
 $I_p$  = maximum short circuit peak current  
 ——— maximum prospective short circuit peak current  
           corresponding at the power factor  
 ——— maximum real peak short circuit current

# DPX<sup>3</sup> 160 + earth leakage DPX<sup>3</sup>-I 160 + earth leakage

Reference(s) : 420 030/ 031/ 032/033/ 034/ 035/ 036/ 037/ 070/ 071/  
072/ 073/ 074/ 075/ 076/ 077/ 110/ 111/ 112/ 113/ 114/ 115/ 116/ 117/  
150/ 151/ 152/ 153/ 154/ 155/ 156/ 157/ 197

## 9.4 Earth leakage curve, instantaneous

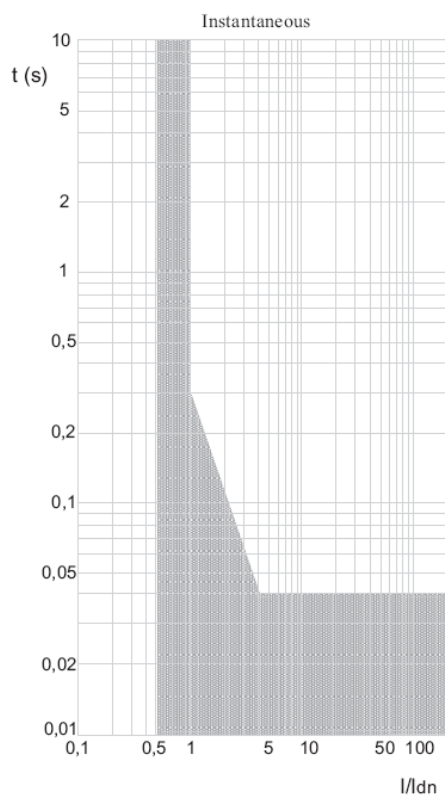

## 9.4 Earth leakage curve, time delay = 0.3 s

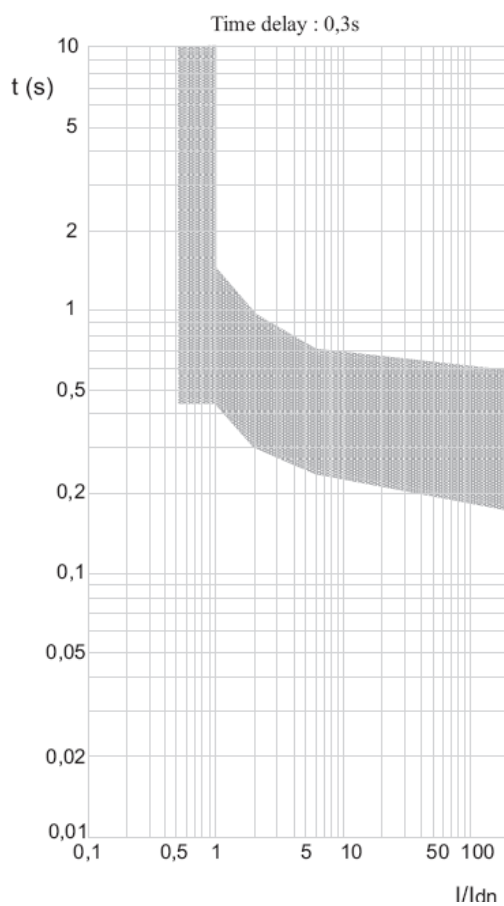

# DPX<sup>3</sup> 160 + earth leakage DPX<sup>3</sup>-I 160 + earth leakage

Reference(s) : 420 030/ 031/ 032/033/ 034/ 035/ 036/ 037/ 070/ 071/  
072/ 073/ 074/ 075/ 076/ 077/ 110/ 111/ 112/ 113/ 114/ 115/ 116/ 117/  
150/ 151/ 152/ 153/ 154/ 155/ 156/ 157/ 197

## 9.4 Earth leakage curve, time delay = 1 s

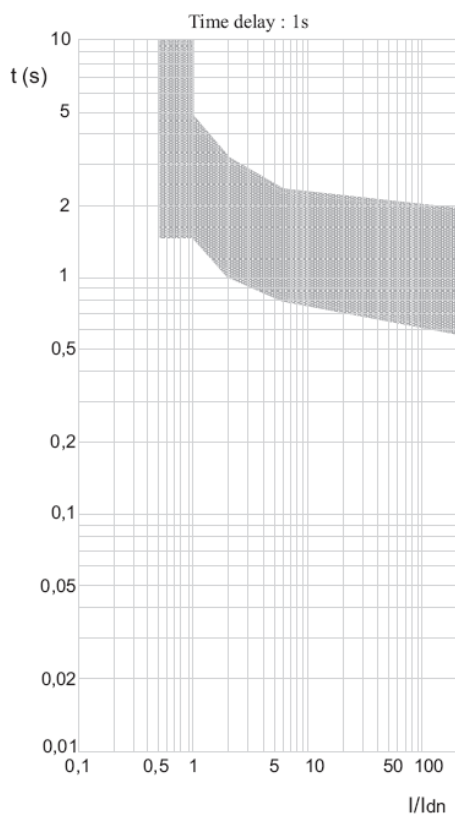

## 9.4 Earth leakage curve, time delay = 3 s

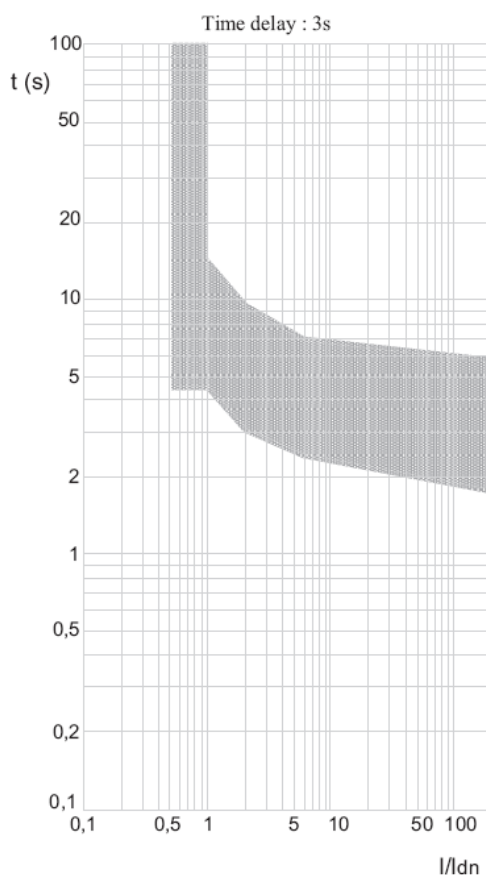

# DPX<sup>3</sup> 160/250

## installation principle

### Auxiliaries mounting

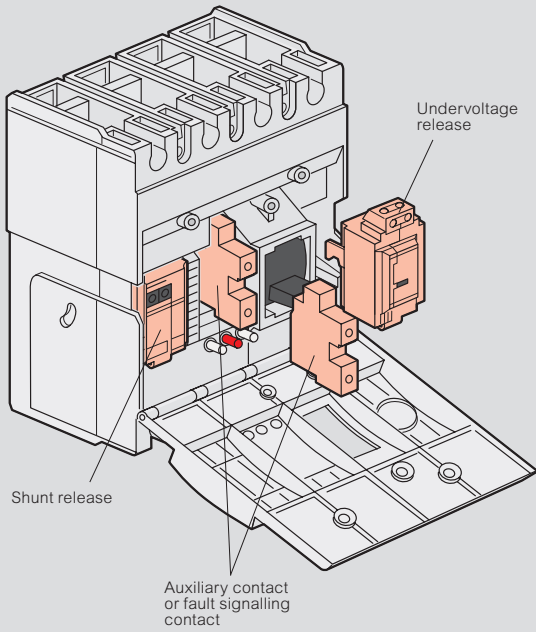

### Side mounting motor-driven handle

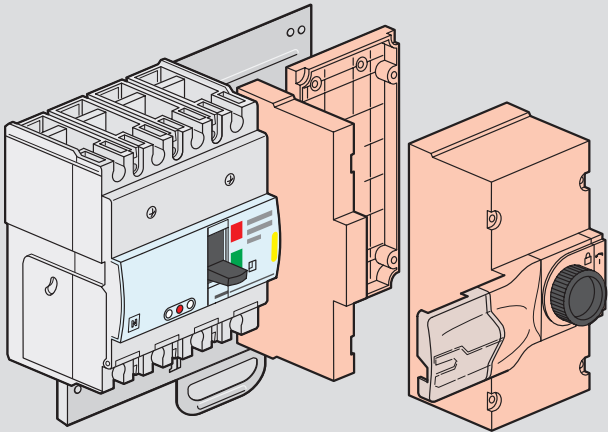

### Front mounting motor-driven handle

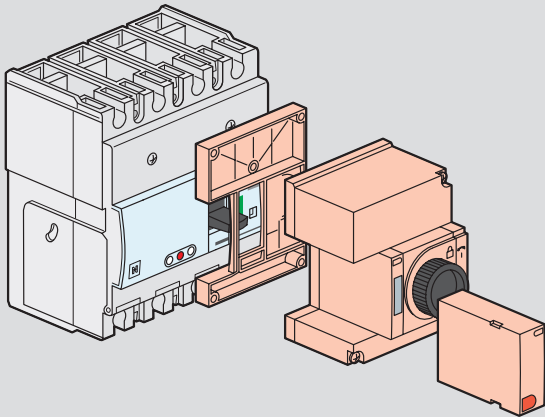

### Direct rotary handle

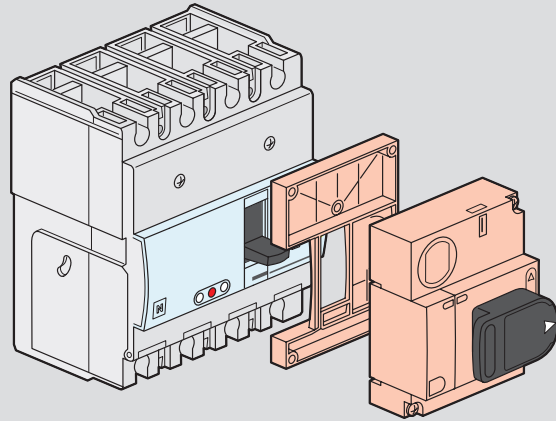

### Plug-in version

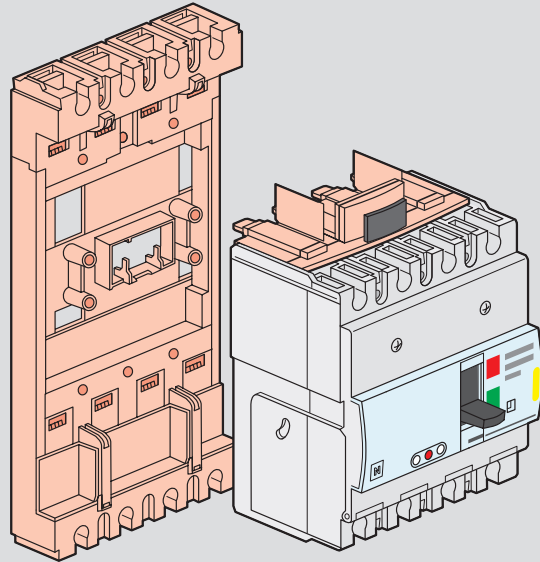

### Supply inverter type

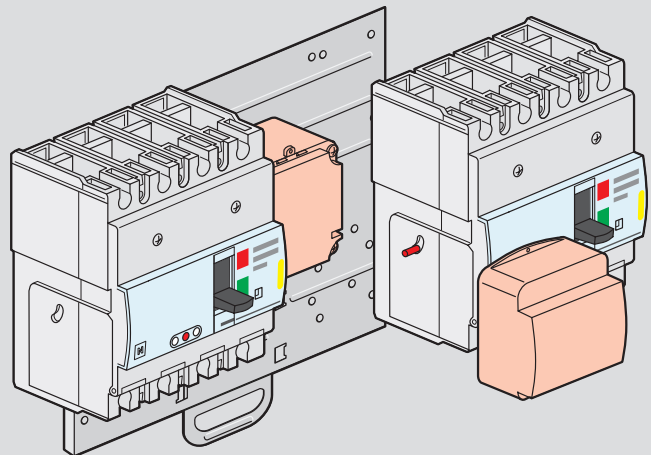

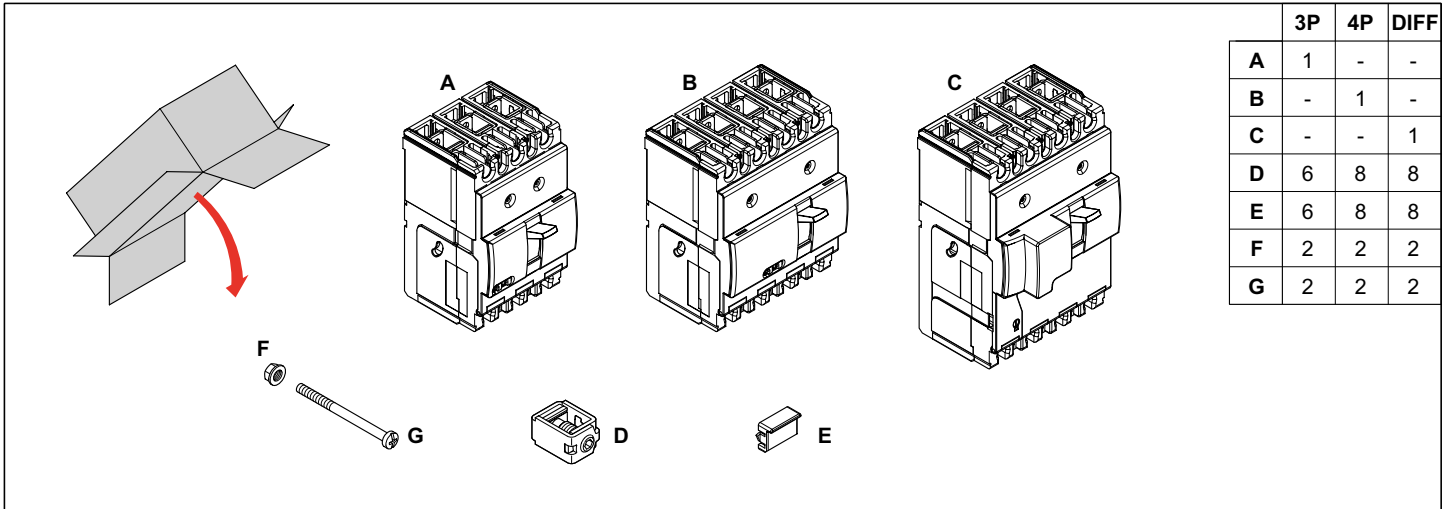

	3P	4P	DIFF
A	1	-	-
B	-	1	-
C	-	-	1
D	6	8	8
E	6	8	8
F	2	2	2
G	2	2	2

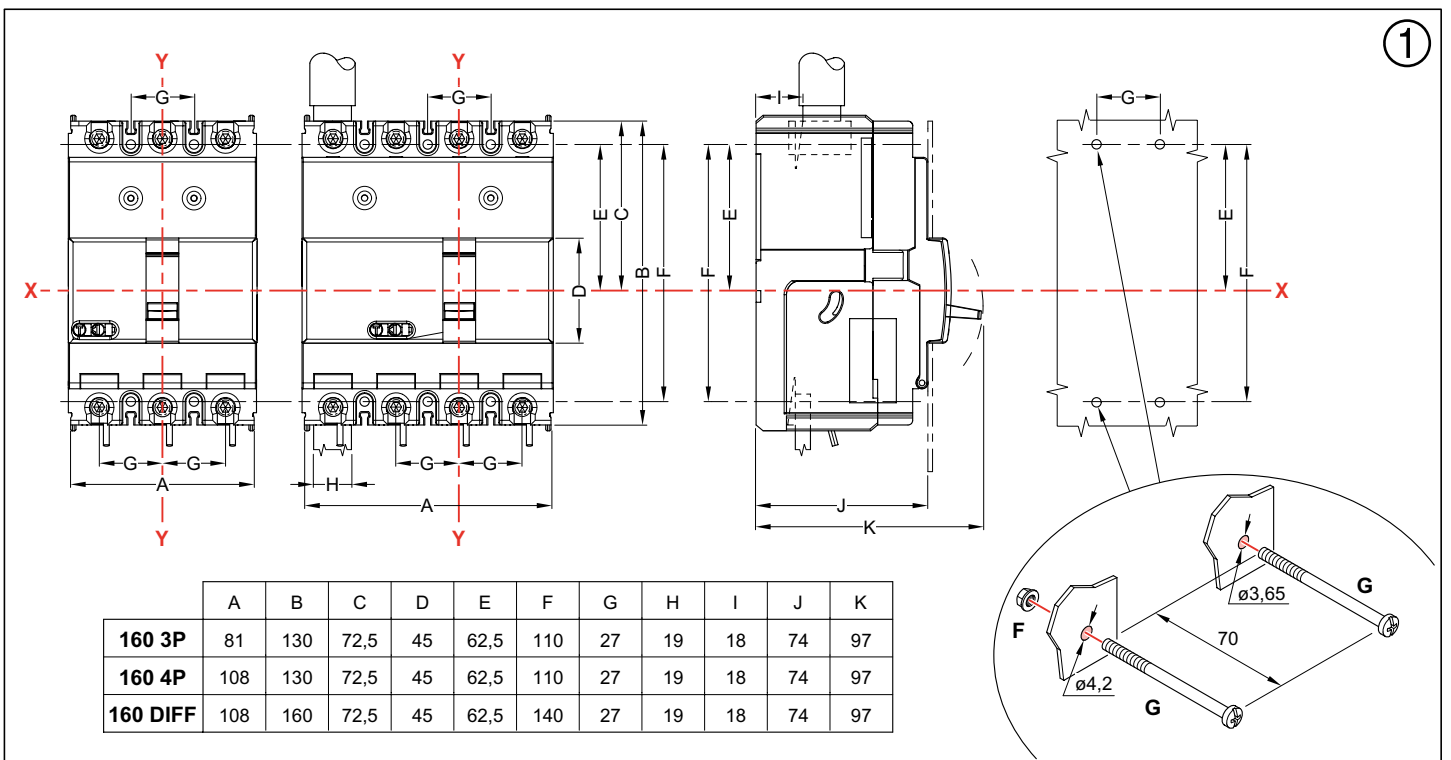

	A	B	C	D	E	F	G	H	I	J	K
160 3P	81	130	72,5	45	62,5	110	27	19	18	74	97
160 4P	108	130	72,5	45	62,5	110	27	19	18	74	97
160 DIFF	108	160	72,5	45	62,5	140	27	19	18	74	97

