

DPX³ 630

thermal magnetic release MCCBs from 250 to 630 A



4 220 02



4 220 07

Dimensions **see e-catalogue**
Electrical characteristics **see e-catalogue**

Moulded case MCCBs for switching, control isolation and protection of low voltage electrical lines

Can be fitted with auxiliaries (p. 146)

Can be used with earth leakage modules (p. 140) or with residual current relays (p. 147)

Supplied complete with:

- fixing screws
- connection plates for bars
- insulated shields (phase barriers)

Conform to IEC 60947-2 - Sealable adjustment

Can be mounted on plate in XL³ cabinets and enclosures

Pack	Cat.Nos		MCCBs thermal magnetic release - fixed version
			Breaking capacity I_{cu} 36 kA (400 V\sim)
			In (A)
1	3P 4P	4 220 00 4 220 05	250
1	4 220 01 4 220 06		320
1	4 220 02 4 220 07		400
1	4 220 03 4 220 08		500
1	4 220 04 4 220 09		630
			3P + N/2
1	4 220 10		320
1	4 220 11		400
1	4 220 12		500
1	4 220 13		630
			Breaking capacity I_{cu} 50 kA (400 V\sim)
			In (A)
1	3P 4P	4 220 14 4 220 19	250
1	4 220 15 4 220 20		320
1	4 220 16 4 220 21		400
1	4 220 17 4 220 22		500
1	4 220 18 4 220 23		630
			3P + N/2
1	4 220 24		320
1	4 220 25		400
1	4 220 26		500
1	4 220 27		630











Pack	Cat.Nos		MCCBs thermal magnetic release - fixed version (continued)
			In (A)
			3P 4P
1	4 220 28	4 220 33	250
1	4 220 29	4 220 34	320
1	4 220 30	4 220 35	400
1	4 220 31	4 220 36	500
1	4 220 32	4 220 37	630
			3P + N/2
1	4 220 38		320
1	4 220 39		400
1	4 220 40		500
1	4 220 41		630
			Breaking capacity I_{cu} 100 kA (400 V\sim)
			In (A)
			3P 4P
1	4 220 42	4 220 47	250
1	4 220 43	4 220 48	320
1	4 220 44	4 220 49	400
1	4 220 45	4 220 50	500
1	4 220 46	4 220 51	630
			3P + N/2
1	4 220 52		320
1	4 220 53		400
1	4 220 54		500
1	4 220 55		630

Dimensions **see e-catalogue**



DPX³

electrical characteristics

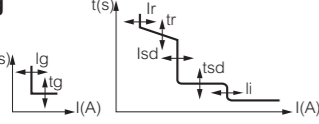
																																									
DEVICES	DPX³ 160 thermal magnetic				DPX³ 250 thermal magnetic				DPX³ 250 electronic release				DPX³ 630 thermal magnetic				DPX³ 630 electronic release				DPX³ 1600 thermal magnetic				DPX³ 1600 electronic release																
Mounting	On rail  or on plate				On rail  or on plate				On rail  or on plate				On plate				On plate				On plate				On plate																
Breaking capacity (kA) (EN 60947-2 and IEC 60947-2)	16 kA	25 kA	36 kA	50 kA	25 kA	36 kA	50 kA	70 kA	25 kA	36 kA	50 kA	70 kA	36 kA	50 kA	70 kA	100 kA	36 kA	50 kA	70 kA	100 kA	36 kA	50 kA	70 kA	100 kA	36 kA	50 kA	70 kA	100 kA	36 kA	50 kA	70 kA	100 kA									
380/415 V~	16	25	36	50	25	36	50	70	25	36	50	70					36	50	70	100	36	50	70	100	36	50	70	100	36	50	70	100									
220/240 V~	25	35	50	65	40	60	100	100	40	60	100	100					70	100	120	170	70	100	120	170	70	100	120	170	70	100	120	170									
Breaking capacity (% Icu)	100	100	100	100	100	100	100	100	100	100	100	100	100	100	100	100	100	100	100	100	100	100	100	100	100	100	100	100	100	100	100										
Characteristic of use																																									
Nominal frequency	50/60 Hz														50/60 Hz																										
Maximum rated operating voltage Ue	690 V (500 V with integrated e.l.c.bs)				690 V (500 V with integrated e.l.c.bs)				690 V (500 V with integrated e.l.c.bs)				690 V~				690 V~				690 V~				690 V~																
Category of use	A				A				A				A				A: In 630 A - B: In 200 to 400 A				A				B																
Thermal magnetic adjustment																																									
 Thermal	0,8 to 1 In				0,8 to 1 In				-				0.8 to 1 In				-				0.8 to 1 In				-																
Magnetic	10 In (400 A for 16 A and 25 A sizes)				5 to 10 In				-				5 to 10 In				-				5 to 10 In				-																
Electronic protection adjustment																																									
 S2															Ir = 0.4 - 1 x In				S2		Sg																				
Sg															Ir : 0.4 to 1 In I _{sd} : 1.5 to 10 Ir																										
Maximum cable cross-section																																									
Rigid cable	150 mm ²				150 mm ²				150 mm ²				300 mm ² or 2 x 240 mm ²				300 mm ² or 2 x 240 mm ²				2 or 4 x 240 mm ²				2 or 4 x 240 mm ²																
Flexible cable	120 mm ²				120 mm ²				120 mm ²				240 mm ² or 2 x 185 mm ²				240 mm ² or 2 x 185 mm ²				2 or 4 x 185 mm ²				2 or 4 x 185 mm ²																
Copper bar and lug width	18 mm				28.5 mm ⁽¹⁾				28.5 mm ⁽¹⁾				32 mm				32 mm				50 mm				50 mm																
Tightening torque	8 Nm				10 Nm				10 Nm				15 Nm				15 Nm				20 Nm				20 Nm																
Nominal current (In) at 40 °C (A)																																									
In (A)	16	25	40	63	80	100	125	160	100	160	200	250	40	100	160	250	250	320	400	500	630	250	320	400	500	630	500	630	800	1000	1250	500	630	800	1000	1250	1600				
Phase	16	25	40	63	80	100	125	160	100	160	200	250	40	100	160	250					250	320	400	500	630	250	320	400	500	630	500	630	800	1000	1250	500	630	800	1000	1250	1600
N	16	25	40	63	80	100	125	160	100	160	200	250	40	100	160	250					250	320	400	500	630	0 - 50 - 100 % of phase value				500	630	800	1000	1250	0 - 50 - 100 % of phase value						
N/2	-	-	-	-	-	-	-	-	-	-	-	-	-	-	-	-	-	-	-	-	-	250	250	250	320	-				-	-	-	500	630	-						
Magnetic threshold (Im) (A)⁽²⁾ of DPX³ thermal magnetic																																									
In (A)	Fixed				Adjustable				Adjustable								Adjustable								Adjustable																
Phase	16	25	40	63	80	100	125	160	100	160	200	250	-	-	-	-	250	320	400	500	630	-	-	-	-	-	500	630	800	1000	1250	-	-	-	-	-					
N	400	400	400	630	800	1000	1250	1600	125-250	200-400	315-630	500-1000	-	-	-	-	1250-2500	1600-3200	2000-4000	2500-5000	3150-6300	-	-	-	-	2500-5000	3150-6300	4000-8000	5000-10000	6250-12500	-	-	-	-	-						
N/2	-	-	-	-	-	-	-	-	-	-	-	-	-	-	-	-	-	1000-2000	1250-2500	1600-2500	2000-4000	-	-	-	-	-	-	-	-	2500-5000	3150-6000	-	-	-	-						
Endurance (cycles)																																									
Electrical	8000				8000				8000				5000				5000				4000				4000																
Mechanical	25000				20000				20000				10000				20000				10000				10000																
Electronic earth leakage module																																									
Type	without or integrated				without or integrated				without or integrated				downstream e.l.c.bs.				downstream e.l.c.bs.				-				-																

1: Copper bars only
2: Trip current for 50/60 Hz. For direct current, multiply by 1.5

 For DPX³ magnetic release only, Please, consult us

DPX³ 630
Thermal magnetic and trip-free switches
DPX³-I 630

Reference(s) : 422 000/ 001/ 002/ 003/ 004/ 005/ 006/ 007/ 008/ 009/ 010/ 011/ 012/ 013/ 014/ 015/ 016/ 017/ 018/ 019/ 020/ 021/ 022/ 023/ 024/ 025/ 026/ 027/ 028/ 029/ 030/ 031/ 032/ 033/ 034/ 035/ 036/ 037/ 038/ 039/ 040/ 041/ 042/ 043/ 044/ 045/ 046/ 047/ 048/ 049/ 050/ 051/ 052/ 053/ 054/ 055 & 422 216/ 217/ 218/ 219

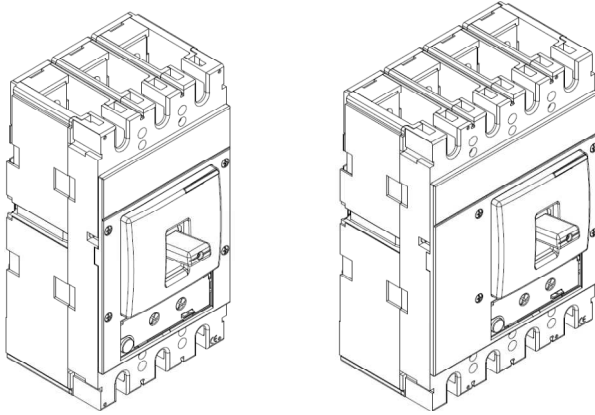
CONTENTS

CONTENTS	PAGES
1. USE	1
2. RANGE	1
3. DIMENSIONS	1
4. OVERVIEW	2
5. ELECTRICAL AND MECHANICAL CHARACTERISTICS	2
6. CONFORMITY	4
7. EQUIPMENTS AND ACCESSORIES	4
8. CURVES	7

1. USE

DPX³ "moulded case" circuit breaker offers optimal solutions to answer to protection requirements of tertiary and industrial installations.

2. RANGE

I _n (A)	36 kA			50 kA		
	3P	4P	3P + N/2	3P	4P	3P + N/2
250	422000	422005	-	422014	422019	-
320	422001	422006	422010	422015	422020	422024
400	422002	422007	422011	422016	422021	422025
500	422003	422008	422012	422017	422022	422026
630	422004	422009	422013	422018	422023	422027
I _n (A)	70 kA			100 kA		
	3P	4P	3P + N/2	3P	4P	3P + N/2
250	422028	422033	-	422042	422047	-
320	422029	422034	422038	422043	422048	422052
400	422030	422035	422039	422044	422049	422053
500	422031	422036	422040	422045	422050	422054
630	422032	422037	422041	422046	422051	422055

I _n (A)	DPX ³ -I	
	3P	4P
250	-	-
320	-	-
400	422216	422218
500	-	-
630	422217	422219

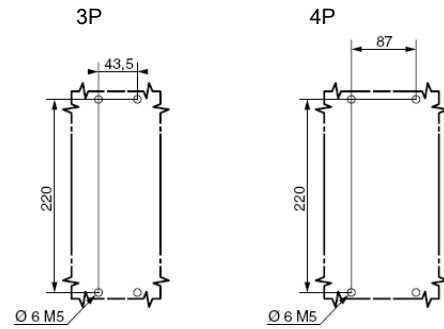
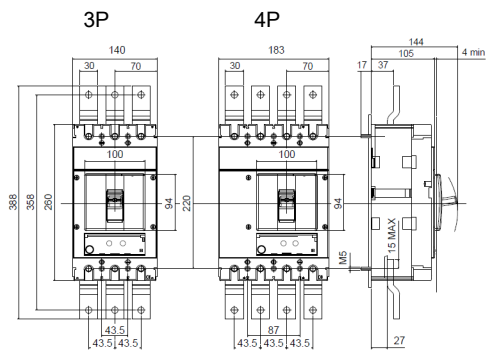
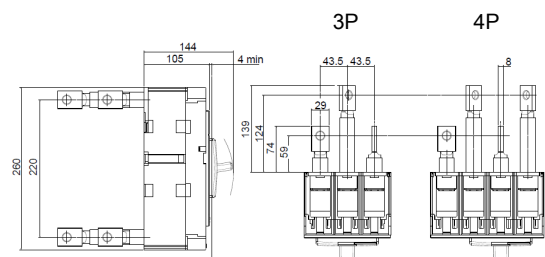
3. DIMENSIONS
Implantation

Fixed version

Fixed version, flat rear terminal

DPX³ 630

Thermal magnetic and trip-free switches

DPX³-I 630

Reference(s) : 422 000/ 001/ 002/ 003/ 004/ 005/ 006/ 007/ 008/ 009/ 010/ 011/ 012/ 013/ 014/ 015/ 016/ 017/ 018/ 019/ 020/ 021/ 022/ 023/ 024/ 025/ 026/ 027/ 028/ 029/ 030/ 031/ 032/ 033/ 034/ 035/ 036/ 037/ 038/ 039/ 040/ 041/ 042/ 043/ 044/ 045/ 046/ 047/ 048/ 049/ 050/ 051/ 052/ 053/ 054/ 055 & 422 216/ 217/ 218/ 219

3. DIMENSIONS (NEXT)

Plug-in version, with cage terminals

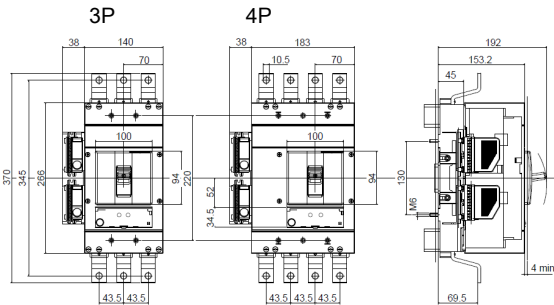

Plug-in version, without cage terminals

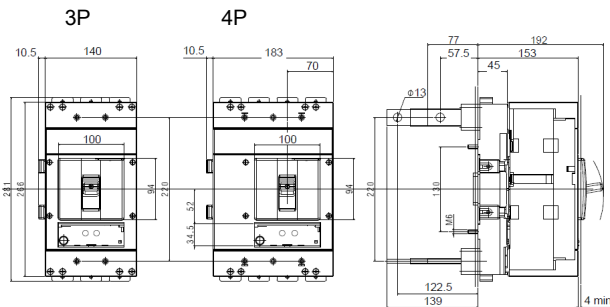

Draw-out version, rear terminals

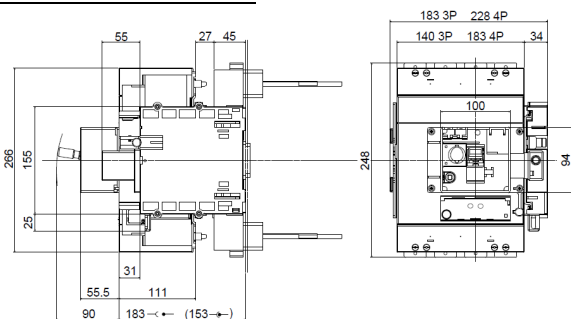

Draw-out version with sliding terminals

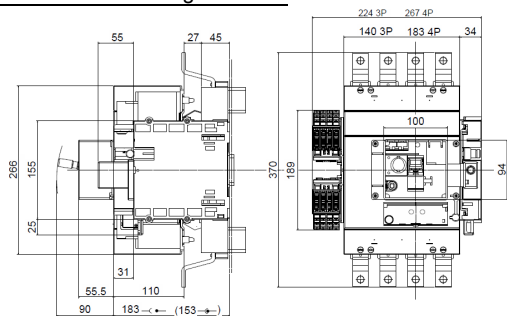

4. OVERVIEW

4.1 Supplied

Supplied with

- fixing screws
- connection plates for bars (width 32mm max)
- phase insulators

4.2 Mounting possibilities

On plate:

- Vertical
- Horizontal
- Supply inverter type

5. ELECTRICAL AND MECHANICAL CHARACTERISTICS

Circuit Breaker	DPX ³ 630 F/N/H/L (36kA, 50kA, 70kA, 100kA)
Nominal current (A)	250, 320, 400, 500, 630
Poles	3 - 4
Rated insulation voltage U _i (V)	800
Rated operating voltage (50/60Hz) U _e (V)	690
Rated impulse withstand current U _{imp} (kV)	8
Nominal frequency (Hz)	50 - 60
Functioning temperature (°C)	40 - 50
Operating temperature (°C)	-25 ÷ 70
Mechanical endurance (cycles)	20000
Mechanical endurance with motor control (cycles)	10000
Electrical endurance at I _n (cycles)	4000
Electrical endurance at 0.5 I _n (cycles)	8000
Utilization category	A
Suitable for isolation	Yes
Type of protection	Thermal-magnetic
Magnetic adjustment	(5 ÷ 10) × I _n
Thermal adjustment	(0.8 ÷ 1) × I _n
Neutral protection for 4P version (%I _{th})	100
Dimensions (W x H x D) (mm)	43.5(xP) x 260 x 105
Weight (kg)	5.4(3P) - 6.85(4P)

Switch	DPX ³ -I
Uninterrupted nominal current I _u (A)	400 - 630
Short-time resistive current I _{cs} (kA) for 1s	5 (400A) - 8 (630A)
Rated short-circuit making capacity I _{cm} (kA)	8(400A) - 14 (630A)
Isolated voltage U _i (V AC)	800
Maximum rated operating voltage U _e (V AC/DC)	690
Rated impulse withstand voltage U _{imp} (kV)	8
Utilisation category	AC23A (400A) - AC22A (630A)
Nominal frequency (Hz)	50-60
Operating temperature (°C)	-25 ÷ 70
Mechanical endurance (cycles)	20000
Mechanical endurance with motor control	10000
Electrical endurance (cycles) at I _n	4000
Electrical endurance (cycles) at 0.5 I _n	8000
Dimensions (W x H x D) (mm)	140 x 260 x 105(3P) 183 x 260 x 105(4P)
Weight (kg)	4.5(3P) - 6.4(4P)

DPX³ 630

Thermal magnetic and trip-free switches

DPX³-I 630

Reference(s) : 422 000/ 001/ 002/ 003/ 004/ 005/ 006/ 007/ 008/ 009/ 010/ 011/ 012/ 013/ 014/ 015/ 016/ 017/ 018/ 019/ 020/ 021/ 022/ 023/ 024/ 025/ 026/ 027/ 028/ 029/ 030/ 031/ 032/ 033/ 034/ 035/ 036/ 037/ 038/ 039/ 040/ 041/ 042/ 043/ 044/ 045/ 046/ 047/ 048/ 049/ 050/ 051/ 052/ 053/ 054/ 055 & 422 216/ 217/ 218/ 219

5.1 Main parts constituting the circuit breaker

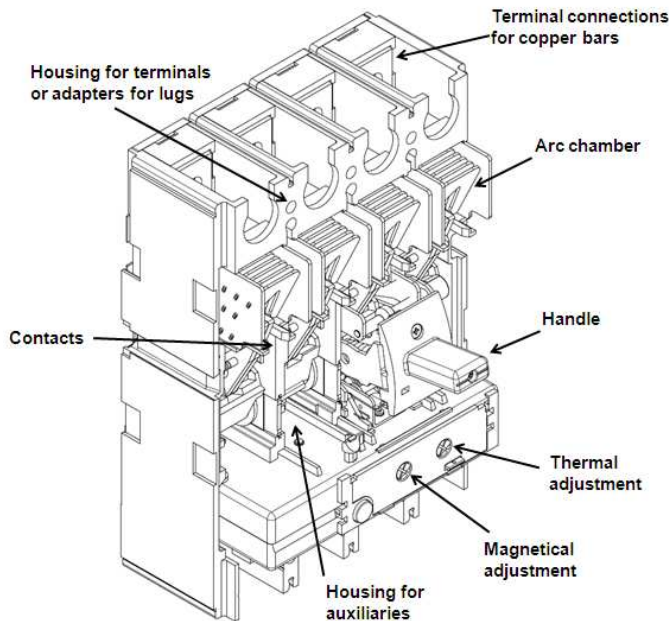

5.2 Breaking capacity (kA)

	Breaking capacity (kA) & I_{cs}			
	3P-4P	3P-4P	3P-4P	3P-4P
U_e/I_{cu}	F	N	H	L
220/240 V AC	70	100	120	150
380/415 V AC	36	50	70	100
440/460 V AC	30	40	60	70
480/500 V AC	25	30	40	50
600 V AC	20	22	25	28
690V AC	14	18	20	22
$I_{cs}(\% I_{cu})$	100	100	100	70
Rated making capacity under short circuit I_{cm}				
I_{cm} (kA) at	75.6	105	154	220

5.3 Nominal current (I_n) at 40°C / 50°C

I_n (A)	Assigned current trip thermal		
	L1 - L2 - L3	N	N/2
250	250	250	160
320	320	320	200
400	400	400	250
500	500	500	320
630	630	630	400

5.4 Power losses per pole under I_n

Circuit breaker

	Power losses per pole (W)									
	I_n (A)									
	250		320		400		500		630	
	Phase	Neutral	Phase	Neutral	Phase	Neutral	Phase	Neutral	Phase	Neutral
Cage terminals	19.2	19.2	16.4	16.4	25.6	18.9	23.6	28.7	37.3	21.2
Lugs	19.2	19.2	16.4	16.4	25.6	18.9	23.6	28.7	37.3	21.2
External lugs	19.9	19.9	17.6	17.6	27.5	19.7	26.6	30.0	42.1	23.1
Spreaders	20.6	20.6	18.8	18.8	29.3	20.4	28.2	30.6	44.7	24.1
Rear terminals	20.4	20.4	18.4	18.4	28.7	20.2	28.5	30.7	45.0	24.3
Plugin version	26.7	26.7	28.8	28.8	44.9	26.5	53.9	41.1	85.3	40.5
Circuit breaker + RCD	22.3	22.3	21.5	21.5	33.6	22.1	36.1	33.8	57.2	29.2

Switch

	Power losses per pole (W)			
	I_n (A)			
	400		630	
	Phase	Neutral	Phase	Neutral
Cage terminals	25.6	25.6	37.3	37.3
Lugs	25.6	25.6	37.3	37.3
External lugs	27.5	27.5	42.1	42.1
Spreaders	29.3	29.3	44.7	44.7
Rear terminals	28.7	28.7	45.0	45.0
Plugin version	44.9	44.9	85.3	85.3
Circuit breaker + RCD	33.6	33.6	57.2	57.2

Total power losses has calculated as the sum of losses of every accessory installed

5.5 FUNCTIONING IN PARTICULAR CONDITIONS

5.5.1 Temperature

I_n (A)	Temperature T_a (°C)						
	10	20	30	40	50	60	70
250	336	307	279	250	250	222	193
320	416	384	352	320	320	288	256
400	475	460	425	400	400	360	320
500	600	550	525	500	500	455	410
630	700	683	650	630	630	580	530

For derating temperature with other configurations, see table A.

5.5.2 Altitude

Altitude (m)	2000	3000	4000	5000
U_e (V)	690	590	520	460
I_n (A) ($T_a = 40^\circ\text{C}/50^\circ\text{C}$)	I_n	$0.98 \times I_n$	$0.93 \times I_n$	$0.9 \times I_n$

5.5.3 Use at 400 Hz

See table B.

5.5.4 Use in DC

See table C.

DPX³ 630

Thermal magnetic and trip-free switches

DPX³-I 630

Reference(s) : 422 000/ 001/ 002/ 003/ 004/ 005/ 006/ 007/ 008/ 009/ 010/ 011/ 012/ 013/ 014/ 015/ 016/ 017/ 018/ 019/ 020/ 021/ 022/ 023/ 024/ 025/ 026/ 027/ 028/ 029/ 030/ 031/ 032/ 033/ 034/ 035/ 036/ 037/ 038/ 039/ 040/ 041/ 042/ 043/ 044/ 045/ 046/ 047/ 048/ 049/ 050/ 051/ 052/ 053/ 054/ 055 & 422 216/ 217/ 218/ 219

6. CONFORMITY

DPX³ range of product concerning circuit-breakers and switch-disconnectors are in full compliance with the EN/IEC standard 60947-2 and 60947-3 respectively.

The certificate are issued by LOVAG and/or by IECEE CB-scheme certification scheme.

All the product range are CE, CCC, EAC, ANCE marked.

DMX³ are full in compliance with the Shipping Register of Lloyds, RINA, Bureau Veritas, Germanishe Lloyds, Norske Veritas and ABS.

6.1 Marking

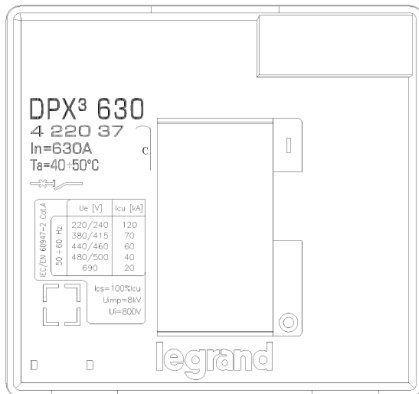

"Tropical climate" :

- execution II (all climates) according to guide UTE C63100

7. EQUIPMENTS AND ACCESSORIES

7.1 Earth leakage modules

Earth leakage characteristics for DPX ³ 630		
	Standard	with Led
Type	A - S	A - S
Uninterrupted nominal current I _n (A)	up to 630	up to 630
Rated isolated voltage U _i (V AC)	500	500
Rated operating voltage U _e (V AC) (50-60Hz)	500	500
Operating voltage (V AC) (50-60Hz)	230 ÷ 500	110 ÷ 500
Nominal frequency (Hz)	50 - 60	50 - 60
Operating temperature (°C)	-25 ÷ 70	-25 ÷ 70
Trip	electronic	electronic
Earth leakage time adjustments (s)	0 - 0.3 - 1 - 3	0 - 0.3 - 1 - 3
Earth leakage breaking capacity I _{dm} (% I _{cu})	60	60
Earth leakage protection adjustments I _{dn} (A)	0.03 ÷ 3	0.03 ÷ 3
Side-by-side mounting	no	no
Underneath mounting	yes	yes
50% Earth fault detection contact I _{dn}	no	yes
Clip on rail DIN 35	no	no
Dimensions (W x H x D) (mm) for 4P	183 x 152 x 105	183 x 152 x 106

(Power losses, see par. 5.4)

Standard

400A	3P	ref. 0 260 60
	4P	ref. 0 260 61
630A	3P	ref. 0 260 64
	4P	ref. 0 260 65

LED version

400A	4P	ref. 0 260 63
630A	4P	ref. 0 260 67

7.2 Releases

- shunt releases (Power consumption = 300 VA) with voltage
 - 24 V AC and DC ref. 4 222 39
 - 48 V AC and DC ref. 4 222 40
 - 110 V AC and DC ref. 4 222 41
 - 230 V AC and DC ref. 4 222 42
 - 400 V AC and DC ref. 4 222 43

- undervoltage releases (Power consumption = 5 VA) with voltage
 - 24 V DC ref. 4 222 44
 - 24 V AC ref. 4 222 45
 - 48 V DC ref. 4 222 46
 - 110 V AC ref. 4 222 47
 - 230 V AC ref. 4 222 48
 - 400 V AC ref. 4 222 49

- time-lag undervoltage releases (800 ms)

Time-lag modules with voltage

24 V AC and DC	ref. 0 261 92
230 V AC	ref. 0 261 90
400 V AC	ref. 0 261 91
Universal Release	ref. 4 226 23

DPX³ 630

Thermal magnetic and trip-free switches

DPX³-I 630

Reference(s) : 422 000/ 001/ 002/ 003/ 004/ 005/ 006/ 007/ 008/ 009/ 010/ 011/ 012/ 013/ 014/ 015/ 016/ 017/ 018/ 019/ 020/ 021/ 022/ 023/ 024/ 025/ 026/ 027/ 028/ 029/ 030/ 031/ 032/ 033/ 034/ 035/ 036/ 037/ 038/ 039/ 040/ 041/ 042/ 043/ 044/ 045/ 046/ 047/ 048/ 049/ 050/ 051/ 052/ 053/ 054/ 055 & 422 216/ 217/ 218/ 219

7.3 Auxiliary contact

Changeover switch 3A – 250 VAC

ref. 4 210 11

To show the state of the contacts or opening of the DPX³ on a fault:

Auxiliary contact (standard) **C**
Fault signal **S**

Auxiliary contact		
Nominal voltage (V _n)	V (AC or DC)	24 to 250
Intensity (A)	24 V DC	5
	48 V DC	1.7
	110 V DC	0.5
	230 V DC	0.25
	110 V AC	4
	230/250 V AC	3

Configurations:

DPX³ 630 → 2 auxiliary contact + 1 fault signal + 1 release

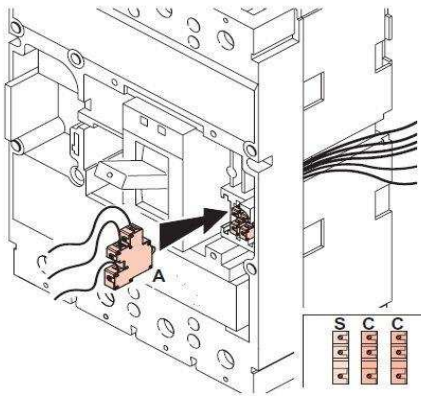

7.4 Rotary handles

Direct on DPX³

- Standard (black) ref. 0 262 41
- For emergency use (red / yellow) adapting on standard handle ref. 4 222 38

Vari-depth handle IP55

- Standard (black) ref. 0 262 81
- For emergency use (red / yellow) adapting on standard handle ref. 0 262 82

Locking accessories

- Profalux type star key (cod. HBA90GPS6149) for vari-depth handle ref. 0 262 93
- Ronis type flat key (cod. ABA90GEL6149) for vari-depth handle ref. 0 262 94

7.5 Motor-driven handles

Front operated

- Voltage 24 V AC and DC ref. 0 261 40
- Voltage 48 V AC and DC ref. 0 261 41
- Voltage 230 V AC ref. 0 261 44

Locking accessories

- Ronis type flat key (cod. ABA90GEL6149) ref. 0 261 59
- Profalux type star key (cod. HBA90GPS6149) ref. 0 261 58

7.6 Mechanical accessories

Phase insulators

- Set of 3 ref. 0 262 30

Sealable terminal shields

- Set of 2 3P ref. 0 262 44
- Set of 2 4P ref. 0 262 45

Terminal covers to guarantee IP20

- Set of 2 3P ref. 4 222 34
- Set of 2 4P ref. 4 222 35

Padlocks

- Accessories to lock in open position ref. 0 262 40

7.7 Connection accessories

Cage terminals

- Set of 4 terminals for cables 300mm² max (rigid) or 240mm² max (flexible) Cu/Al ref. 0 262 50
- Set of 4 terminals for cables 2x240mm² max (rigid) or 2x180mm² max (flexible) Cu/Al ref. 0 262 51

Extended front terminals

- Set of 4 ref. 0 262 47

Spreaders

- Set of 3 (incoming or outgoing 3P) ref. 0 262 48
- Set of 4 (incoming or outgoing 4P) ref. 0 262 49

Rear terminals

(use to connect fixed version with front terminals into fixed version with rear terminals)

- Set of swivel terminals, incoming or outgoing
 - 3P ref. 0 263 50
 - 4P ref. 0 263 51
- Set of flat rear terminals, incoming or outgoing
 - 3P ref. 0 263 52
 - 4P ref. 0 263 53

7.8 Plug-in version

(A plug-in is a DPX³ fitted with tulip contacts mounted on a base)

Terminals for plug-in & draw-out base

- Set of 6 terminals (3P) ref. 4 222 20
- Set of 8 terminals (4P) ref. 4 222 21

Tulip contact

- Set of tulip contact (supplied with an incoming/outgoing protective cover)
 - 3P ref. 0 265 50
 - 4P ref. 0 265 51

Bases

- front terminal mounting base
 - 3P ref. 4 222 22
 - 4P ref. 4 222 23
- flat rear terminal mounting base
 - 3P ref. 4 222 24
 - 4P ref. 4 222 25

Bases with earth leakage underneath mounting

- front terminal mounting base ref. 4 222 26
- Flat rear terminal mounting base ref. 4 222 27

DPX³ 630

Thermal magnetic and trip-free switches

DPX³-I 630

Reference(s) : 422 000/ 001/ 002/ 003/ 004/ 005/ 006/ 007/ 008/ 009/ 010/ 011/
012/ 013/ 014/ 015/ 016/ 017/ 018/ 019/ 020/ 021/ 022/ 023/ 024/ 025/ 026/ 027/
028/ 029/ 030/ 031/ 032/ 033/ 034/ 035/ 036/ 037/ 038/ 039/ 040/ 041/ 042/ 043/
044/ 045/ 046/ 047/ 048/ 049/ 050/ 051/ 052/ 053/ 054/ 055 & 422 216/ 217/ 218/
219

Accessories

- Set of 2 extractor handles ref. 4 222 28
- Set of connectors (8-pin) ref. 0 263 99
- Set of connectors (24 pin – 3x8 or 2x12) ref. 4 222 29
- Signal contact (plugged-in / drawn-out) ref. 0 265 74
- Support plate for plug-in version ref. 4 222 37

7.9 Draw-out version

(A DPX³ draw-out version is a plug-in DPX³ fitted with a "Débro-lift" mechanism which can be used to withdraw the DPX³ while keeping it on its base)

"Débro-lift" mechanism

- For DPX³ base only
 - 3P ref. 4 222 31
 - 4P ref. 4 222 32
- For DPX³ 4P base with earth leakage module ref. 4 222 33

Key lock for "Débro-lift" mechanism

- For DPX³ only
 - Ronis type flat key (cod. ABA90GEL6149) ref. 0 265 76
 - Profalux type star key (cod. HBA90GPS6149) ref. 0 263 48
- For motorized DPX³ or with rotary handle
 - Ronis type flat key(cod. ABA90GEL6149) ref. 0 265 78
 - Profalux type star key (cod. HBA90GPS6149) ref. 0 265 77

Accessories for "Débro-lift" mechanism

- Isolated handle for drawing-out ref. 0 265 75
- Signal contact (plugged-in / drawn-out) ref. 0 265 74
- Support plate for draw-out version ref. 4 222 36
- Automatic auxiliary contacts (6 pin) for D/O version (2 pieces installable max.) ref. 4 222 30

DPX³ 630
Thermal magnetic and trip-free switches
DPX³-I 630

Reference(s) : 422 000/ 001/ 002/ 003/ 004/ 005/ 006/ 007/ 008/ 009/ 010/ 011/ 012/ 013/ 014/ 015/ 016/ 017/ 018/ 019/ 020/ 021/ 022/ 023/ 024/ 025/ 026/ 027/ 028/ 029/ 030/ 031/ 032/ 033/ 034/ 035/ 036/ 037/ 038/ 039/ 040/ 041/ 042/ 043/ 044/ 045/ 046/ 047/ 048/ 049/ 050/ 051/ 052/ 053/ 054/ 055 & 422 216/ 217/ 218/ 219

8. CURVES

8.1 TRIPPING CURVE

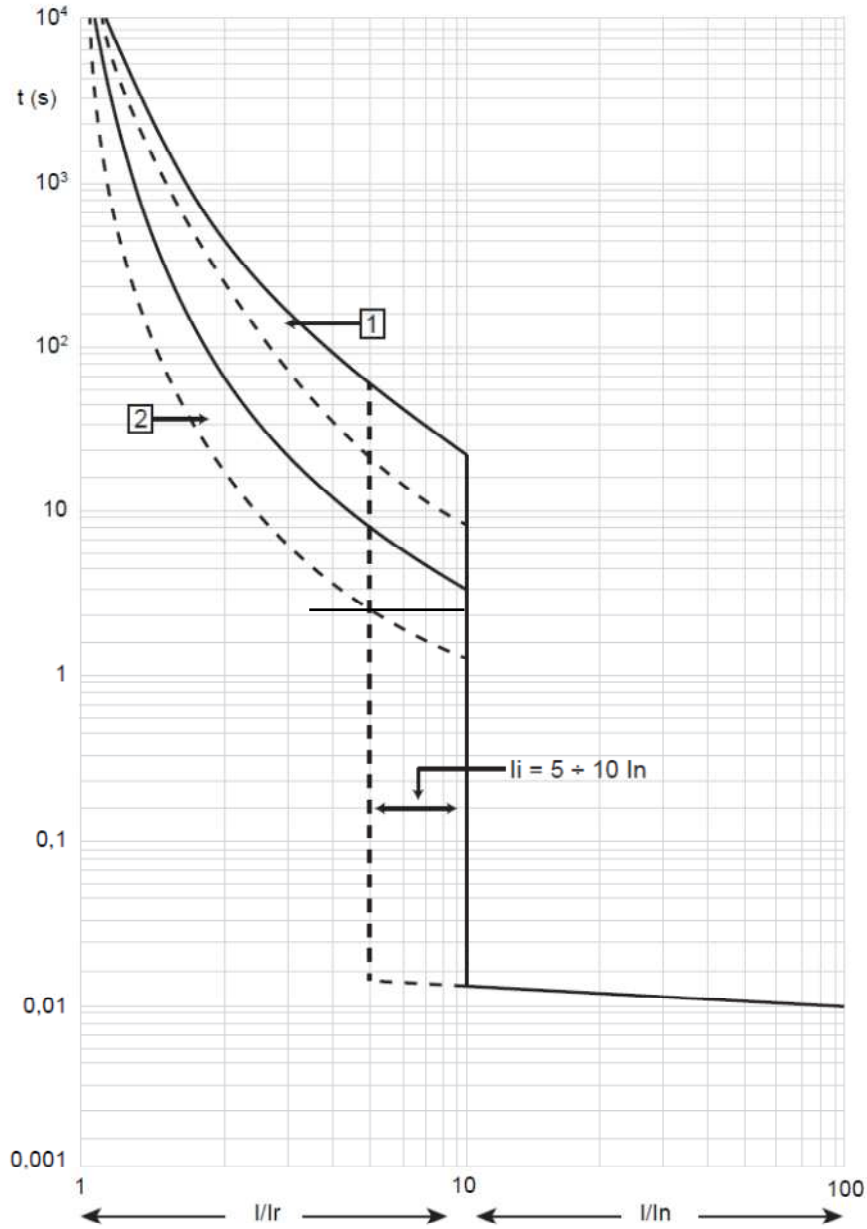

$I_{cu} = 36-50-70-100 \text{ kA}$ $I_{max} = 630\text{A}$ 3-4 P $U_e = 415\text{Vac}$

Value	Description
t	time
I	current
I_n	rated current
I_r	long time setting current
curve 1	characteristic with cold start
curve 2	characteristic with hot start

(*) please, for magnetic current value I_i consider a normative tolerance of $\pm 20\%$

DPX³ 630
Thermal magnetic and trip-free switches
DPX³-I 630

Reference(s) : 422 000/ 001/ 002/ 003/ 004/ 005/ 006/ 007/ 008/ 009/ 010/ 011/
 012/ 013/ 014/ 015/ 016/ 017/ 018/ 019/ 020/ 021/ 022/ 023/ 024/ 025/ 026/ 027/
 028/ 029/ 030/ 031/ 032/ 033/ 034/ 035/ 036/ 037/ 038/ 039/ 040/ 041/ 042/ 043/
 044/ 045/ 046/ 047/ 048/ 049/ 050/ 051/ 052/ 053/ 054/ 055 & 422 216/ 217/ 218/
 219

8.2 RESTRICTED CURVE IN THERMAL CONSTRAINT

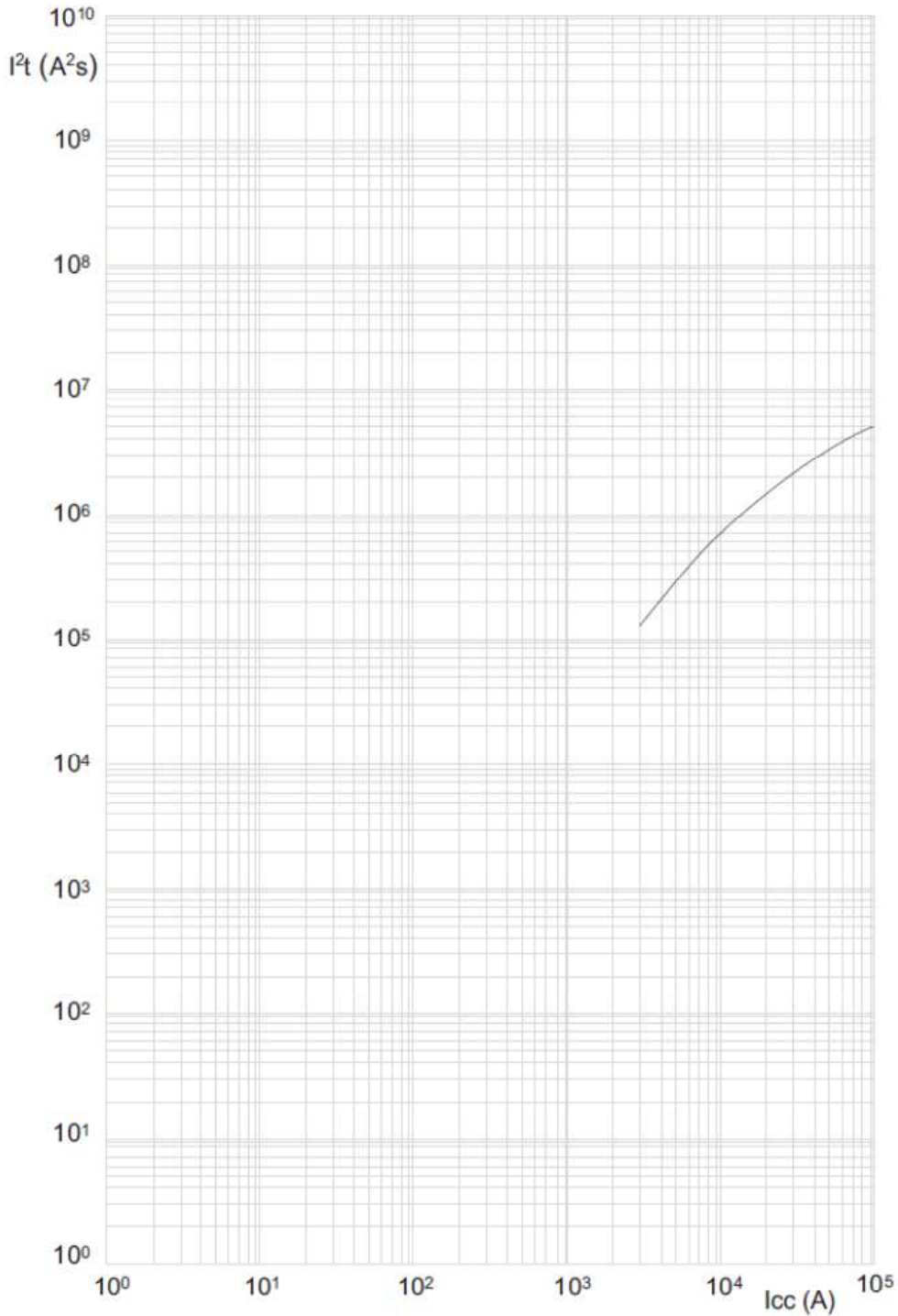

$I_{cu} = 36-50-70-100 \text{ kA}$ $I_{max} = 630\text{A}$ 3-4 P $U_e = 415\text{Vac}$

Value	Description
I_{cc}	short circuit current
$I^2t \text{ (A}^2\text{s)}$	pass-through specific energy



DPX³ 630
Thermal magnetic and trip-free switches
DPX³-I 630

Reference(s) : 422 000/ 001/ 002/ 003/ 004/ 005/ 006/ 007/ 008/ 009/ 010/ 011/
 012/ 013/ 014/ 015/ 016/ 017/ 018/ 019/ 020/ 021/ 022/ 023/ 024/ 025/ 026/ 027/
 028/ 029/ 030/ 031/ 032/ 033/ 034/ 035/ 036/ 037/ 038/ 039/ 040/ 041/ 042/ 043/
 044/ 045/ 046/ 047/ 048/ 049/ 050/ 051/ 052/ 053/ 054/ 055 & 422 216/ 217/ 218/
 219

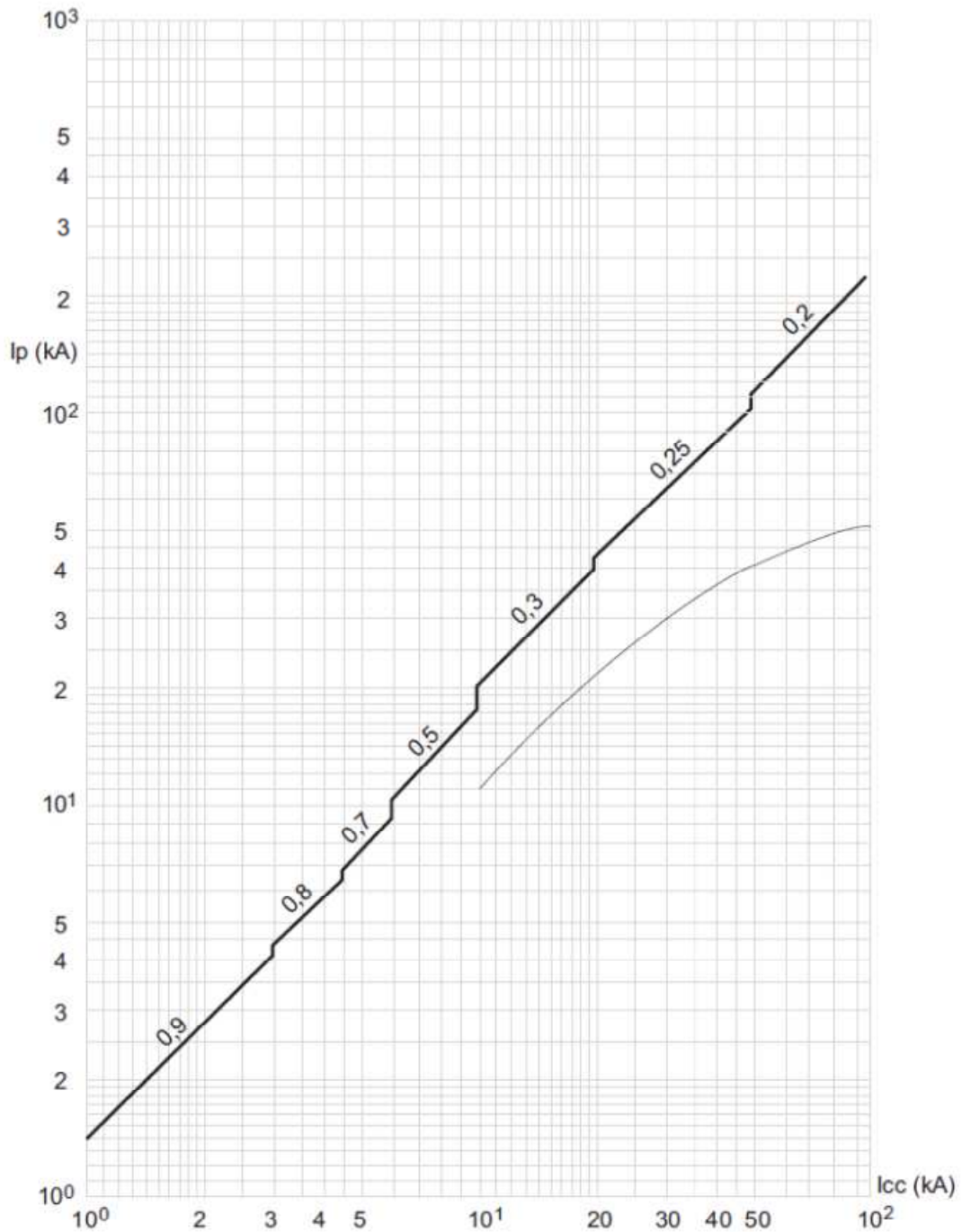
8.3 RESTRICTED CURRENT CURVE



$I_{cu} = 36-50-70-100 \text{ kA}$ $I_{max} = 630A$ 3-4 P $U_e = 415Vac$

Value	Description
I_{cc}	estimated short circuit symmetrical current (RMS value)
I_p	maximum short circuit peak current
	maximum prospective short circuit peak current corresponding at the power factor
	maximum real peak short circuit current

DPX³ 630

Thermal magnetic and trip-free switches

DPX³-I 630

Reference(s) : 422 000/ 001/ 002/ 003/ 004/ 005/ 006/ 007/ 008/ 009/ 010/ 011/ 012/ 013/ 014/ 015/ 016/ 017/ 018/ 019/ 020/ 021/ 022/ 023/ 024/ 025/ 026/ 027/ 028/ 029/ 030/ 031/ 032/ 033/ 034/ 035/ 036/ 037/ 038/ 039/ 040/ 041/ 042/ 043/ 044/ 045/ 046/ 047/ 048/ 049/ 050/ 051/ 052/ 053/ 054/ 055 & 422 216/ 217/ 218/ 219

A) Derating Temperature and configurations

		Ambient temperature											
		30 °C		40 °C		50 °C		60 °C		65 °C		70 °C	
Fixed version		I_{max} (A)	I_r / I_n	I_{max} (A)	I_r / I_n	I_{max} (A)	I_r / I_n	I_{max} (A)	I_r / I_n	I_{max} (A)	I_r / I_n	I_{max} (A)	I_r / I_n
DPX ³ 630 fixed	Cage terminals, flexible cable	630	1	630	1	630	1	599	0.95	567	0.9	536	0.85
	Lugs, flexible cable	630	1	630	1	630	1	599	0.95	567	0.9	536	0.85
	Lugs, rigid cable	630	1	630	1	630	1	599	0.95	567	0.9	536	0.85
	Spreaders, flexible cable	630	1	630	1	630	1	599	0.95	504	0.8	473	0.75
	Spreaders, Cu bars	630	1	630	1	630	1	567	0.9	536	0.85	504	0.8
	Rear flat staggered terminals, flexible cable	630	1	630	1	630	1	599	0.95	504	0.8	473	0.75
	Rear flat staggered terminals, Cu bars, vertical	630	1	630	1	630	1	567	0.9	536	0.85	504	0.8
	Rear tang terminals, flexible cable	630	1	630	1	630	1	567	0.9	504	0.8	473	0.75
DPX ³ 630 fixed + RCD	Cage terminals, flexible cable + RCD	599	0.95	567	0.9	567	0.9	504	0.8	473	0.75	441	0.7
	Lugs, flexible cable + RCD	599	0.95	567	0.9	567	0.9	504	0.8	473	0.75	441	0.7
	Lugs, rigid cable + RCD	599	0.95	567	0.9	567	0.9	504	0.8	473	0.75	441	0.7
	Spreaders, flexible cable + RCD	536	0.85	536	0.85	536	0.85	473	0.75	410	0.65	378	0.6
	Spreaders, Cu bars + RCD	567	0.9	536	0.85	536	0.85	504	0.8	441	0.7	378	0.6
	Rear flat staggered terminals, flexible cable + RCD	567	0.9	567	0.9	567	0.9	473	0.75	410	0.65	378	0.6
	Rear flat staggered terminals, Cu bars, vertical + RCD	567	0.9	567	0.9	567	0.9	504	0.8	441	0.7	378	0.6
	Rear tang terminals, flexible cable + RCD	504	0.8	504	0.8	504	0.8	473	0.75	410	0.65	378	0.6
Draw-out version		I_{max} (A)	I_r / I_n	I_{max} (A)	I_r / I_n	I_{max} (A)	I_r / I_n	I_{max} (A)	I_r / I_n	I_{max} (A)	I_r / I_n	I_{max} (A)	I_r / I_n
DPX ³ 630 draw-out	Cage terminals, flexible cable	599	0.95	567	0.9	536	0.85	504	0.8	473	0.75	441	0.7
	Rear flat terminals, flexible cable	599	0.95	567	0.9	536	0.85	504	0.8	473	0.75	441	0.7
	Rear flat terminals, Cu bars, vertical	599	0.95	567	0.9	536	0.85	504	0.8	473	0.75	441	0.7
DPX ³ 630 draw-out + RCD	Cage terminals, flexible cable + RCD	536	0.85	504	0.8	473	0.75	441	0.7	410	0.65	378	0.6
	Cage terminals, Cu bars + RCD	536	0.85	504	0.8	473	0.75	441	0.7	410	0.65	378	0.6
	Rear flat terminals, flexible cable + RCD	536	0.85	504	0.8	473	0.75	441	0.7	410	0.65	378	0.6
	Rear flat terminals, Cu bars, vertical + RCD	536	0.85	504	0.8	473	0.75	441	0.7	410	0.65	378	0.6

B) Correct factor for adjustment for use at 400 Hz

In (A) at 50 Hz	Thermal adjustment		Magnetic adjustment		
	Correction factor	I_n (A) at 400Hz	Correction factor	I_m (A) MIN at 400Hz	I_m (A) MAX at 400Hz
250	0.85	213	1	1250	2500
320	0.85	272	1	1600	3200
400	0.8	320	1	2000	4000
500	0.8	400	1	2500	5000
630	0.8	504	1	3150	6300

C) Breaking capacity in DC (kA)

Circuit breaker	I_n (A)	1 pole	2 poles in series				3 poles in series		4 poles in series			Protection		
		≤55-60V	≤55-60V	≤110-125V	250V	250V	400V	250V	400V	500V	Thermal	Magnetic	Earth leakage	
DPX ³ 630 ($I_{cu} = 36$ kA)	250 - 320 - 400	40	N/A	40	36	N/A	40	N/A	N/A	40	like AC	1.5 I_i AC	No protection	
DPX ³ 630 ($I_{cu} = 50$ kA)	250 - 320 - 400	45	N/A	45	40	N/A	45	N/A	N/A	45	like AC	1.5 I_i AC	No protection	
DPX ³ 630 ($I_{cu} = 70$ kA)	250 - 320 - 400	45	N/A	45	40	N/A	45	N/A	N/A	45	like AC	1.5 I_i AC	No protection	
DPX ³ 630 ($I_{cu} = 100$ kA)	250 - 320 - 400	50	N/A	50	45	N/A	50	N/A	N/A	50	like AC	1.5 I_i AC	No protection	
DPX ³ 630 ($I_{cu} = 36$ kA)	500 - 630	40	N/A	40	36	N/A	40	N/A	N/A	40	like AC	1.5 I_i AC	No protection	
DPX ³ 630 ($I_{cu} = 50$ kA)	500 - 630	45	N/A	45	40	N/A	40	N/A	N/A	40	like AC	1.5 I_i AC	No protection	
DPX ³ 630 ($I_{cu} = 70$ kA)	500 - 630	45	N/A	45	40	N/A	45	N/A	N/A	45	like AC	1.5 I_i AC	No protection	
DPX ³ 630 ($I_{cu} = 100$ kA)	500 - 630	50	N/A	50	45	N/A	50	N/A	N/A	50	like AC	1.5 I_i AC	No protection	

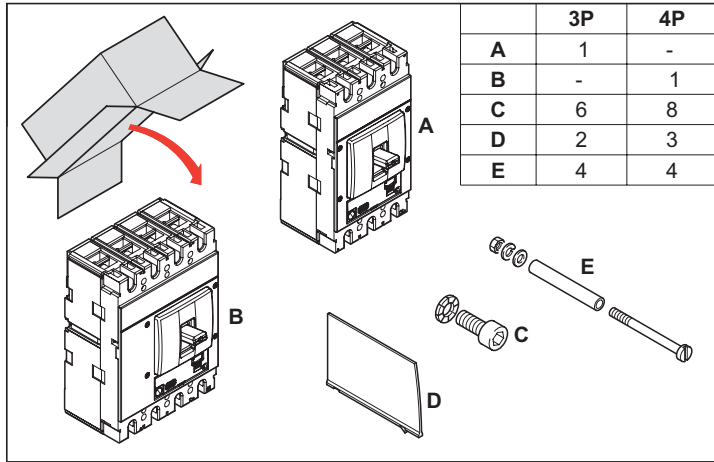

	3P	4P
A	1	-
B	-	1
C	6	8
D	2	3
E	4	4

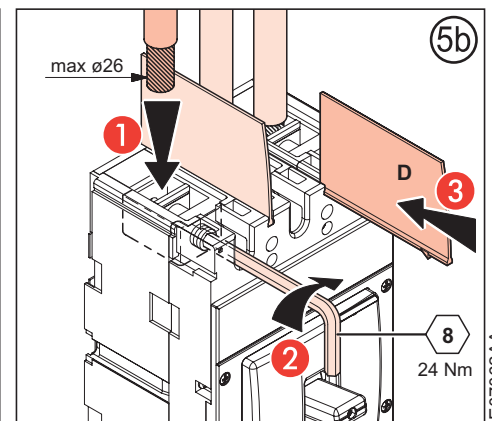
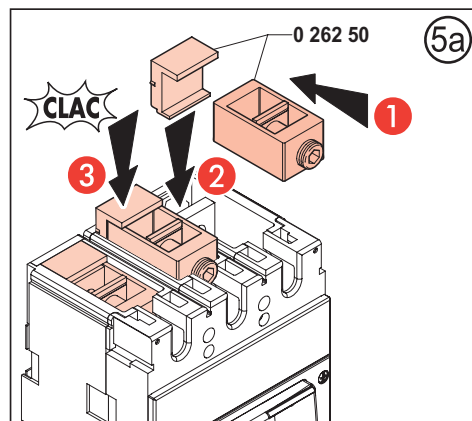
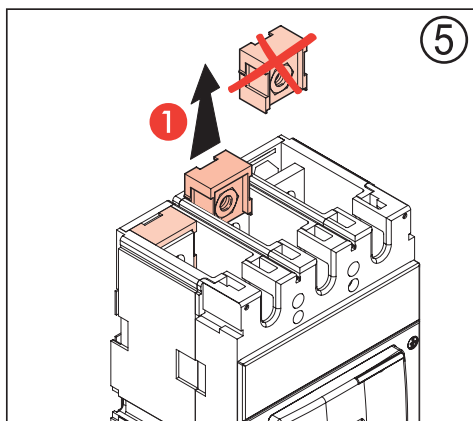
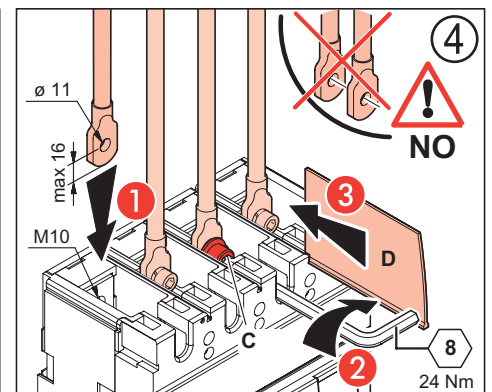
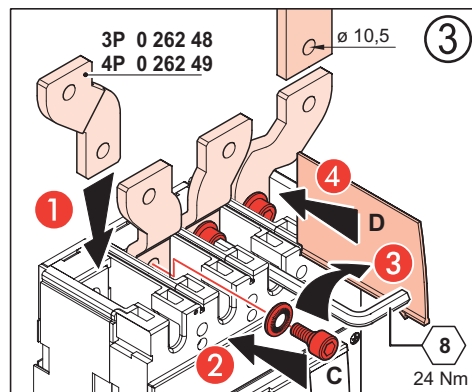
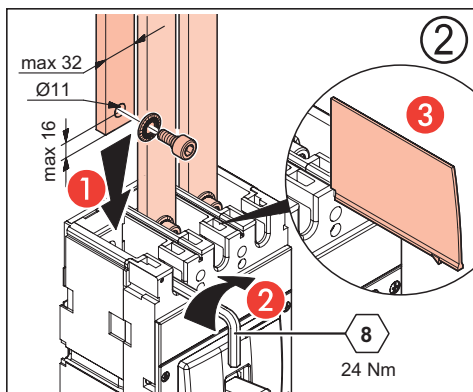
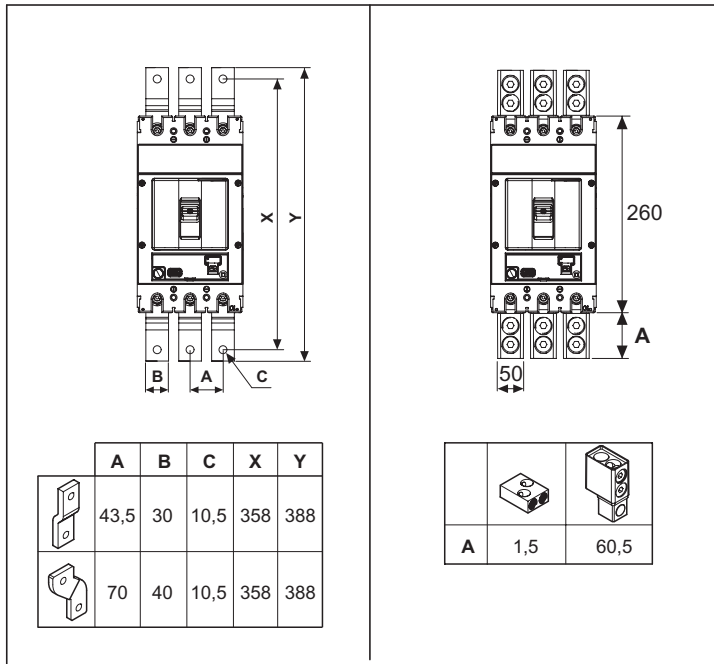
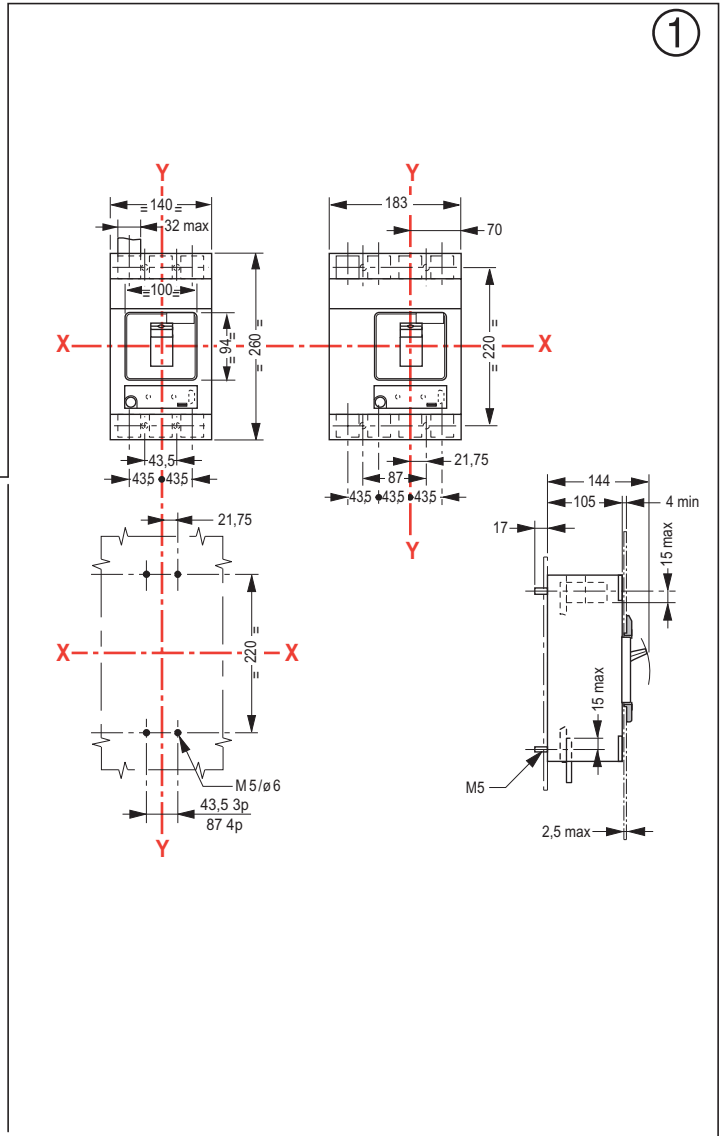

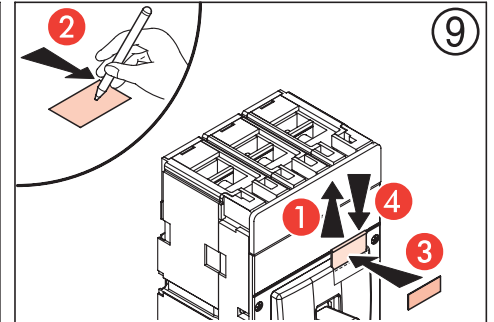
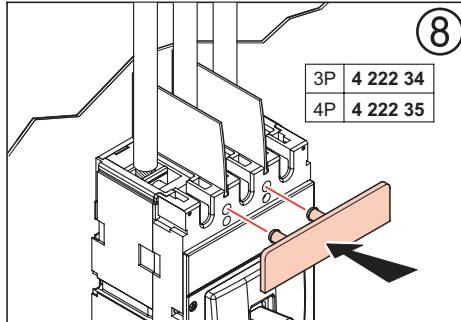
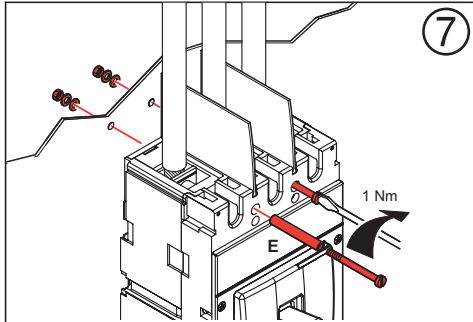
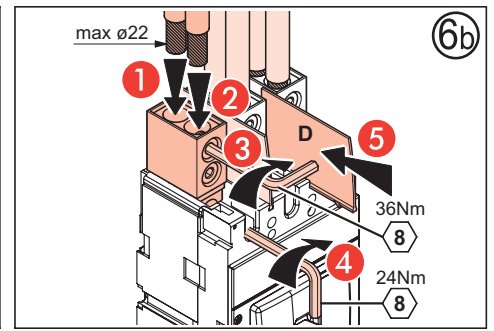
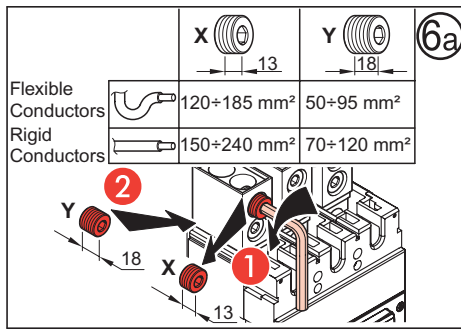
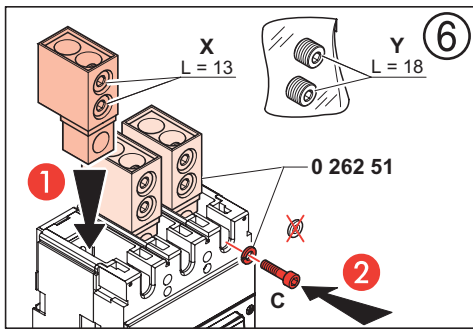

Consignes de surlit

Ce produit doit être installé conformément aux règles d'installation et de préférence par un électricien qualifié. Une installation et une utilisation incorrectes peuvent entraîner des risques de choc électrique ou d'incendie. Avant d'effectuer l'installation, lire la notice, tenir compte du lieu de montage spécifique au produit. Ne pas ouvrir, démonter, altérer ou modifier l'appareil sauf mention particulière indiquée dans la notice. Tous les produits Legrand doivent exclusivement être ouverts et réparés par du personnel formé et habilité par Legrand. Toute ouverture ou réparation non autorisée annule l'intégralité des responsabilités, droits à remplacement et garanties. Utiliser exclusivement les accessoires de la marque Legrand.

(FR) (BE) (CA) (LU) (CH)



Safety instructions

This product should be installed in compliance with installation rules, preferably by a qualified electrician. Incorrect installation and use can lead to risk of electric shock or fire. Before carrying out the installation, read the instructions and take account of the product's specific mounting location. Do not open up, dismantle, alter or modify the device except where specifically required to do so by the instructions. All Legrand products must be opened and repaired exclusively by personnel trained and approved by Legrand. Any unauthorised opening or repair completely cancels all liabilities and the rights to replacement and guarantees. Use only Legrand brand accessories.

(GB) (CA) (IN) (IE) (US)



Sicherheitshinweise

Dieses Produkt darf nur durch eine Elektro-Fachkraft eingebaut werden. Bei falschem Einbau bzw. Umgang besteht das Risiko eines elektrischen Schlages oder Brandes. Vor der Installation die Anleitung lesen, den produktspezifischen Montageort beachten. Das Gerät vorbehaltlich besonderer, in der Betriebsanleitung angegebener Hinweise nicht öffnen, zerlegen, beschädigen oder abändern. Alle Produkte von Legrand dürfen ausschließlich von durch Legrand geschultes und anerkanntes Personal geöffnet und repariert werden. Durch unbefugte Öffnung oder Reparatur erlöschen alle Haftungs-, Ersatz- und Gewährleistungsansprüche. Ausschliesslich Zubehör der Marke Legrand benutzen.

(DE)



Consignas de seguridad

Este producto debe instalarse conforme a las normas de instalación y preferiblemente por un electricista cualificado. Una instalación y una utilización incorrectas pueden entrañar riesgos de choque eléctrico o de incendio. Antes de efectuar la instalación, leer las instrucciones, tener en cuenta el lugar de montaje específico del producto.

No abrir, desmontar, alterar o modificar el aparato salvo que esto se indique específicamente en las instrucciones. Todos los productos Legrand deben ser abiertos y reparados exclusivamente por personal formado y habilitado por Legrand. Cualquier apertura o reparación no autorizada anula la totalidad de las responsabilidades, derechos a sustitución y garantías. Utilizar exclusivamente los accesorios de la marca Legrand.

(ES) (CL) (CO) (GR) (MX) (PE) (US) (VE)



Istruzioni di sicurezza

Questo prodotto deve essere installato in conformità con le regole d'installazione e di preferenza da un elettricista qualificato. L'eventuale installazione e utilizzo improprio dello stesso possono comportare rischi di shock elettrico o incendio. Prima di procedere all'installazione, leggere attentamente le istruzioni associate e individuare un luogo di montaggio idoneo in funzione del prodotto. Non aprire, smontare, alterare o modificare l'apparecchio eccetto speciale menzione indicata nel manuale. Tutti i prodotti Legrand devono essere esclusivamente aperti e riparati da personale adeguatamente formato e autorizzato da Legrand. Qualsvoglia apertura o riparazione non autorizzata comporta l'esclusione di eventuali responsabilità, diritti alla sostituzione e garanzie. Utilizzare esclusivamente accessori a marchio Legrand.

(IT) (CH)



Instruções de segurança

Este produto deve ser instalado de acordo com as regras de instalação e de preferência por um electricista qualificado. A instalação e o uso incorrectos podem provocar riscos de choque eléctrico ou de incêndio. Antes de efectuar a instalação, ler as instruções e ter em conta a localização adequada para a montagem do produto. Não abrir, desmontar, alterar ou modificar o aparelho salvo especificação em contrário nas instruções do produto. Todos os produtos Legrand só devem ser abertos e reparados exclusivamente por pessoal formado e autorizado pela Legrand. Qualquer abertura ou reparação não autorizada cancela todas as responsabilidades, direitos de substituição e garantias. Utilizar exclusivamente os acessórios da marca Legrand.

(PT)



Меры предосторожности

Установка данного изделия должна выполняться в соответствии с правилами монтажа и предпочтительно квалифицированным электриком. Неправильный монтаж или нарушение правил эксплуатации изделия могут привести к возникновению пожара или поражению электрическим током. Перед монтажом необходимо внимательно ознакомиться с данной инструкцией, а также принять во внимание требования к месту установки изделия.

Запрещается вскрывать корпус изделия, а также разбирать, выводить из строя или модифицировать изделие, кроме случаев, оговоренных в инструкции. Вскрытие и ремонт изделий марки Legrand могут выполняться только специалистами, обученными и допущенными к таким работам компанией Legrand. Несанкционированное вскрытие или выполнение ремонтных работ посторонними лицами лишает законной силы любые требования об ответственности, замене или гарантийном обслуживании. При ремонте или гарантийном обслуживании использовать только запасные части марки Legrand.

(RU)



Przepisy bezpieczeństwa

Produkt ten powinien być montowany zgodnie z zasadami instalacji, najlepiej przez wykwalifikowanego elektryka. Niepoprawna instalacja lub złe użytkowanie mogą spowodować ryzyko porażenia prądem lub pożaru. Przed przystąpieniem do instalacji, zapoznać się z instrukcją i uwzględnić miejsce montażu urządzenia.

Nie otwierać, nie demontować ani nie modyfikować urządzenia, jeśli nie ma na ten temat specjalnej wzmianki w instrukcji. Wszystkie produkty Legrand mogą być otwierane i naprawiane wyłącznie przez pracowników przeszkolonych i upoważnionych przez Legrand. Każde otwarcie lub naprawa dokonane bez odpowiedniego upoważnienia zwalnia Legrand od wszelkiej odpowiedzialności, powoduje utratę prawa do wymiany produktu i wygaśnięcie gwarancji. Używać wyłącznie oryginalnych części marki Legrand.

(PL)



Güvenlik talimatları

Bu ürün montaj kurallarına uygun olarak ve tercihen yetkili bir elektrikçi tarafından yerleştirilmelidir. Hatalı bir yerleştirme ve kullanımı, elektrik çarpmasına veya yangına neden olabilir. Yerleştirmeden önce, talimatları okuyun ve ürüne özgü montaj yerine dikkat ediniz. Kılavuzda aksi belirtilmediği sürece cihazı açmayın, sökmez veya üzerinde değişiklik yapmayın. Tüm Legrand ürünlerinin yalnız Legrand tarafından eğitilmiş ve yetkilendirilmiş personel tarafından açılması ve tamir edilmesi gerekir. İzin verilmeyen herhangi bir açılma veya tamir, tüm sorumlulukları, değiştirme haklarını ve garantileri iptal eder. Yalnızca Legrand marka aksesuarları kullanın.

(TR) (CY)



安全说明

该产品应由拥有电工资格的人进行安装。错误的安装和使用会导致发生触电或火灾等危险。

安装前，请仔细阅读安装说明并且考虑产品特殊的安装位置。

除安装说明上特殊要求外，不要随意拆开、拆除以及改动该装置。

所有罗格朗的产品都只能被罗格朗培训并认可的人员拆开和维修。任何未经授权的拆开或维修将被完全取消更换和保证的权利。