

DPX³ 630

Sg electronic release MCCBs from 250 to 630 A



4 221 38



4 221 43

Dimensions **see e-catalogue**
Electrical characteristics **see e-catalogue**

Moulded case MCCBs for switching, control isolation and protection of low voltage electrical lines

Can be fitted with auxiliaries (p. 146)

Can be used with earth leakage modules (p. 140) or with residual current relays (p. 147)

Supplied complete with:

- fixing screws
- connection plates for bars
- insulated shields (phase barriers)

Conform to IEC 60947-2 - Sealable adjustment

Can be mounted on plate in XL³ cabinets and enclosures

Pack	Cat.Nos		MCCBs electronic release Sg - fixed version
			Adjustment of I_r , I_{sd} , I_g , t_r , t_{sd} , t_g (p. 137) Instantaneous protection $I_f = 5$ kA Green indicator lamp Connector for test unit Logic and dynamic selectivity 4P version: adjustment of neutral on front panel
			Breaking capacity Icu 36 kA (400 V~)
	3P	4P	I_n (A)
1	4 221 36	4 221 41	250
1	4 221 37	4 221 42	320
1	4 221 38	4 221 43	400
1	4 221 39	4 221 44	500
1	4 221 40	4 221 45	630
			Breaking capacity Icu 50 kA (400 V~)
1	4 221 46	4 221 51	250
1	4 221 47	4 221 52	320
1	4 221 48	4 221 53	400
1	4 221 49	4 221 54	500
1	4 221 50	4 221 55	630
			Breaking capacity Icu 70 kA (400 V~)
1	4 221 56	4 221 61	250
1	4 221 57	4 221 62	320
1	4 221 58	4 221 63	400
1	4 221 59	4 221 64	500
1	4 221 60	4 221 65	630
			Breaking capacity Icu 100 kA (400 V~)
1	4 221 66	4 221 71	250
1	4 221 67	4 221 72	320
1	4 221 68	4 221 73	400
1	4 221 69	4 221 74	500
1	4 221 70	4 221 75	630

Pack	Cat.Nos		MCCBs electronic release Sg with energy metering central unit - fixed version
			Adjustment of I_r , I_{sd} , I_g , t_r , t_{sd} , t_g (p. 137) Instantaneous protection $I_f = 5$ kA Green indicator lamp Connector for test unit Logic and dynamic selectivity 4P version: adjustment of neutral on front panel
			Breaking capacity Icu 36 kA (400 V~)
	3P	4P	I_n (A)
1	4 221 76	4 221 81	250
1	4 221 77	4 221 82	320
1	4 221 78	4 221 83	400
1	4 221 79	4 221 84	500
1	4 221 80	4 221 85	630
			Breaking capacity Icu 50 kA (400 V~)
1	4 221 86	4 221 91	250
1	4 221 87	4 221 92	320
1	4 221 88	4 221 93	400
1	4 221 89	4 221 94	500
1	4 221 90	4 221 95	630
			Breaking capacity Icu 70 kA (400 V~)
1	4 221 96	4 222 01	250
1	4 221 97	4 222 02	320
1	4 221 98	4 222 03	400
1	4 221 99	4 222 04	500
1	4 222 00	4 222 05	630
			Breaking capacity Icu 100 kA (400 V~)
1	4 222 06	4 222 11	250
1	4 222 07	4 222 12	320
1	4 222 08	4 222 13	400
1	4 222 09	4 222 14	500
1	4 222 10	4 222 15	630

Dimensions **see e-catalogue**



DPX³ 630

S1 electronic release MCCBs from 250 to 630 A



4 225 15

Dimensions **see e-catalogue**
Electrical characteristics **see e-catalogue**

Moulded case MCCBs for switching, control isolation and protection of low voltage electrical lines
Can be fitted with auxiliaries (p. 146)
Can be used with earth leakage modules (p. 140) or with residual current relays (p. 147)
Do not accept DPX³ electronic interface for Modbus Cat.No 4 210 75 (p. 146)
Supplied complete with:
- fixing screws
- connection plates for bars
- insulated shields (phase barriers)
Conform to IEC 60947-2 - Sealable adjustment
Can be mounted on plate in XL³ cabinets and enclosures

Pack	Cat.Nos		MCCBs electronic release S1 - fixed version
			Adjustment of Ir, Isd (opposite) Instantaneous protection If = 5 kA Green indicator lamp Connector for test unit Dynamic selectivity 4P version: adjustment of neutral on front panel
			Breaking capacity Icu 36 kA (400 V~)
	3P	4P	In (A)
1	4 224 98	4 225 03	250
1	4 224 99	4 225 04	320
1	4 225 00	4 225 05	400
1	4 225 01	4 225 06	500
1	4 225 02	4 225 07	630
			Breaking capacity Icu 50 kA (400 V~)
1	4 225 08	4 225 13	250
1	4 225 09	4 225 14	320
1	4 225 10	4 225 15	400
1	4 225 11	4 225 16	500
1	4 225 12	4 225 17	630
			Breaking capacity Icu 70 kA (400 V~)
1	4 225 18	4 225 23	250
1	4 225 19	4 225 24	320
1	4 225 20	4 225 25	400
1	4 225 21	4 225 26	500
1	4 225 22	4 225 27	630
			Breaking capacity Icu 100 kA (400 V~)
1	4 225 28	4 225 33	250
1	4 225 29	4 225 34	320
1	4 225 30	4 225 35	400
1	4 225 31	4 225 36	500
1	4 225 32	4 225 37	630

For DPX 630 electronic release S1 **please consult us**



DPX³ 630/1600

electronic release

Performance data

S1 - Adjustment of Ir, Isd

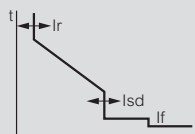

Protection against overloads:
- Ir adjustable from 0.4 to 1 x In
Protection against short circuits:
- Isd adjustable from 1.5 to 10 x Ir
Instantaneous protection If = 5 kA

S2 - Adjustment of Ir, tr, Isd, tsd

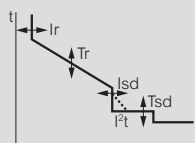

Protection against overloads:
- Ir adjustable from 0.4 to 1 x In
- tr adjustable from 3 to 15 s
Protection against short circuits:
- Isd adjustable from 1.5 to 10 x Ir
- tsd adjustable from 0 to 0.5 s

Sg - Adjustment of Ir, tr, Isd, tsd, Ig, tg

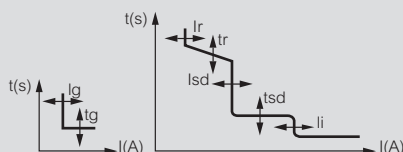

Protection against overloads:
- Ir adjustable from 0.4 to 1 x In
- tr adjustable from 3 to 15 s
Protection against short circuits:
- Isd adjustable from 1.5 to 10 x Ir
- tsd adjustable from 0 to 0.5 s
Protection against earth fault:
- Ig adjustable: from 0.2 to 1 x In and OFF position
- tg adjustable from 0.1 to 1 s

■ Dimensions

Fixed version, front terminals

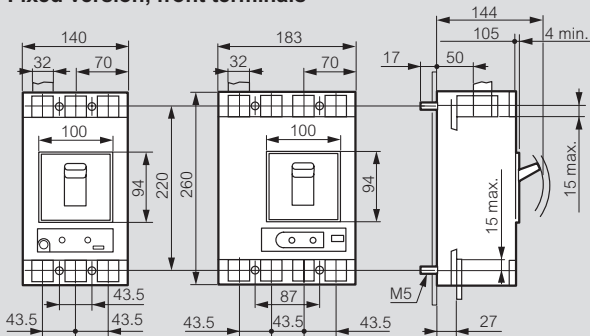

Fixed version with earth leakage module mounted underneath

Front terminals

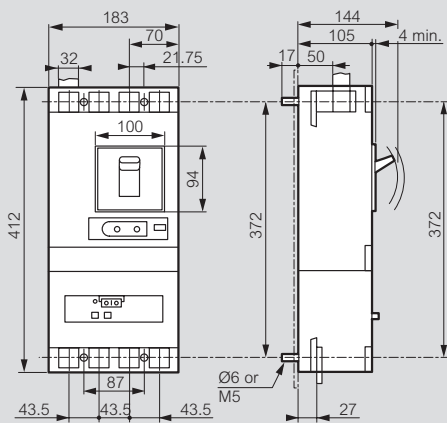

Plug-in version, front terminals

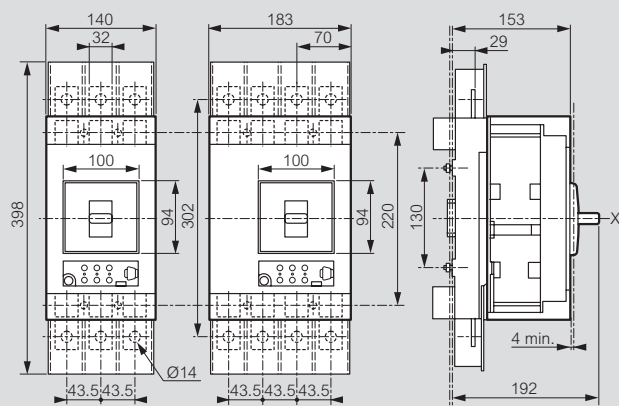

Plug-in version, rear terminals

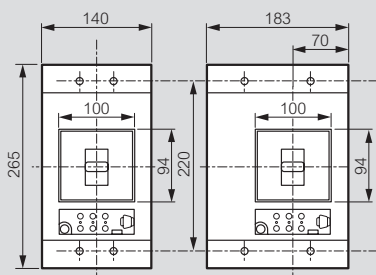

Draw-out version, front terminals

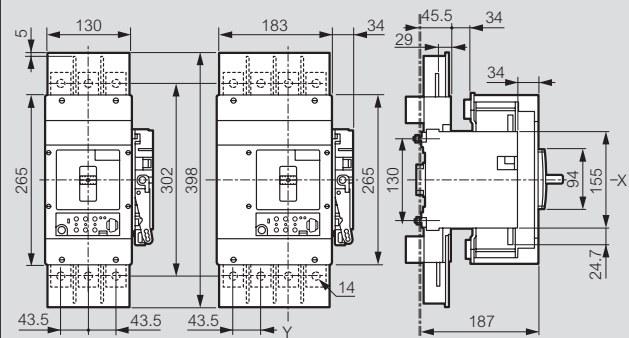

Draw-out version, rear terminals

Flat rear terminal

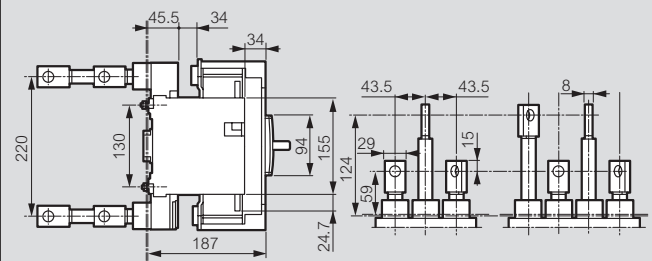

Rotary handle-direct on DPX³

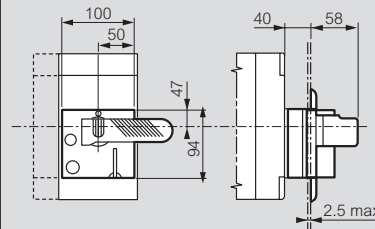

Terminal shields

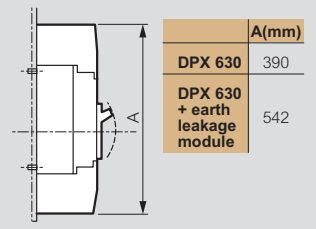

Rotary handle-vari-depth handle on door

Mounting with flexible seal

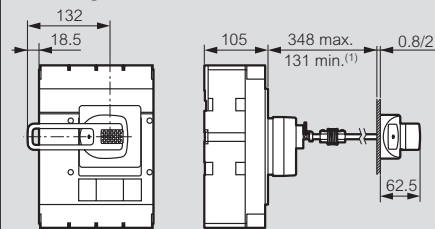

1: 75 mm without mechanical system

DPX³ 630

Electronic release

Reference(s) : **from 422 056 to 422 215 and**
from 422 498 to 422 537

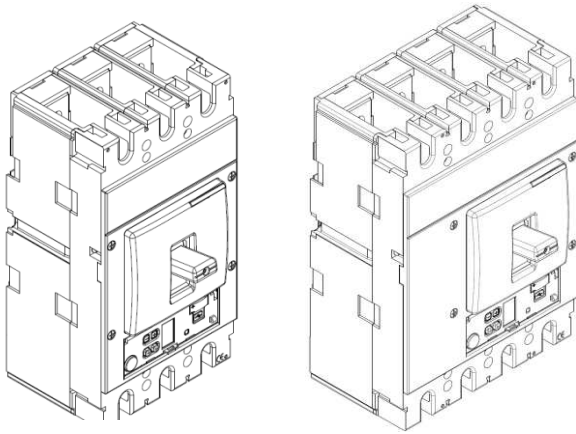

CONTENTS	PAGES
1. USE	1
2. RANGE	1
3. DIMENSIONS	1
4. OVERVIEW	2
5. ELECTRICAL AND MECHANICAL CHARACTERISTICS	2
6. CONFORMITY	3
7. EQUIPMENTS AND ACCESSORIES	3
8. CURVES AND TABLES	6

1. USE

DPX³ "moulded case" circuit breaker offers optimal solutions to answer to protection requirements of tertiary and industrial installations.

2. RANGE

	S1		S2		S2 + measure		Sg		Sg + measure	
	36kA		36kA		36kA		36kA		36kA	
<i>I_n</i> (A)	3P	4P	3P	4P	3P	4P	3P	4P	3P	4P
250	422498	422503	422056	422061	422096	422101	422136	422141	422176	422181
320	422499	422504	422057	422062	422097	422102	422137	422142	422177	422182
400	422500	422505	422058	422063	422098	422103	422138	422143	422178	422183
500	422501	422506	422059	422064	422099	422104	422139	422144	422179	422184
630	422502	422507	422060	422065	422100	422105	422140	422145	422180	422185
	50kA		50kA		50kA		50kA		50kA	
	3P	4P	3P	4P	3P	4P	3P	4P	3P	4P
250	422508	422513	422066	422071	422106	422111	422146	422151	422186	422191
320	422509	422514	422067	422072	422107	422112	422147	422152	422187	422192
400	422510	422515	422068	422073	422108	422113	422148	422153	422188	422193
500	422511	422516	422069	422074	422109	422114	422149	422154	422189	422194
630	422512	422517	422070	422075	422110	422115	422150	422155	422190	422195
	70kA		70kA		70kA		70kA		70kA	
	3P	4P	3P	4P	3P	4P	3P	4P	3P	4P
250	422518	422523	422076	422081	422116	422121	422156	422161	422196	422201
320	422519	422524	422077	422082	422117	422122	422157	422162	422197	422202
400	422520	422525	422078	422083	422118	422123	422158	422163	422198	422203
500	422521	422526	422079	422084	422119	422124	422159	422164	422199	422204
630	422522	422527	422080	422085	422120	422125	422160	422165	422200	422205
	100kA		100kA		100kA		100kA		100kA	
	3P	4P	3P	4P	3P	4P	3P	4P	3P	4P
250	422528	422533	422086	422091	422126	422131	422166	422171	422206	422211
320	422529	422534	422087	422092	422127	422132	422167	422172	422207	422212
400	422530	422535	422088	422093	422128	422133	422168	422173	422208	422213
500	422531	422536	422089	422094	422129	422134	422169	422174	422209	422214
630	422532	422537	422090	422095	422130	422135	422170	422175	422210	422215

3. DIMENSIONS

Implantation

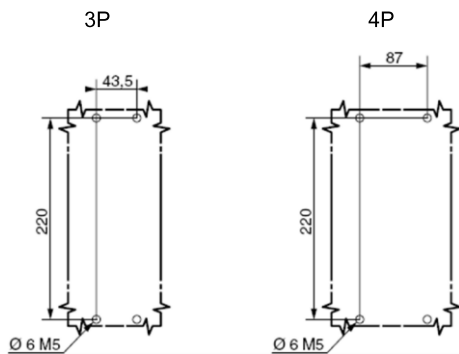

3. DIMENSIONS (NEXT)

Front terminals

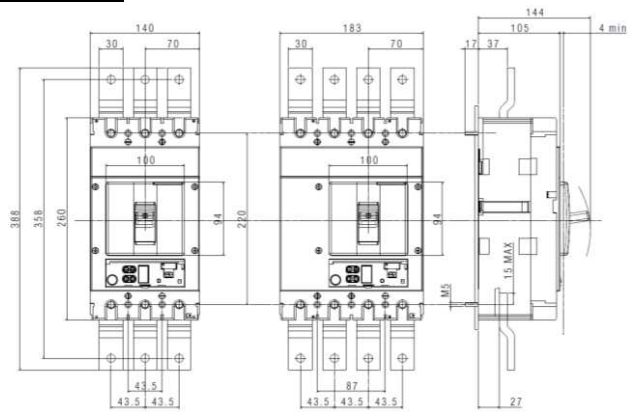

Plug-in version, rear terminals

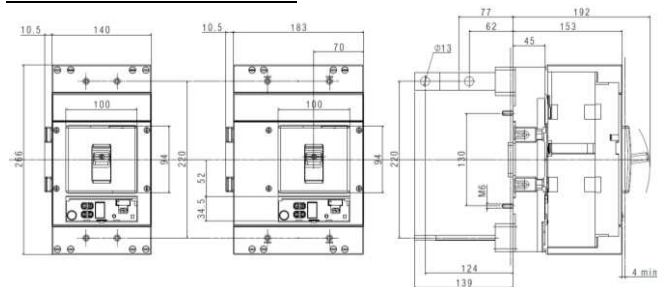

Draw-out version with automatic auxiliary contacts

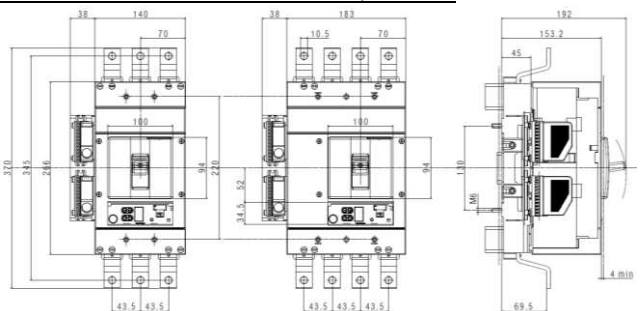

DPX³ 630

Electronic release

Reference(s) : from 422 056 to 422 215 and
from 422 498 to 422 537

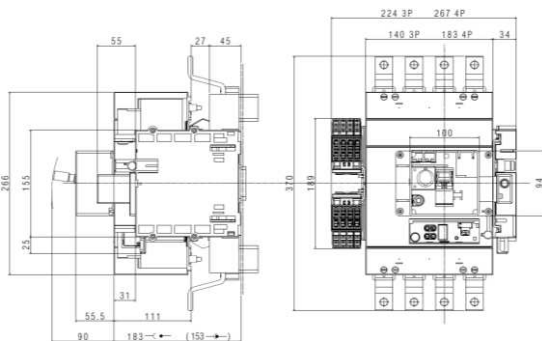

4. OVERVIEW

4.1 Supplied

Connection plates for bars:

- Width 32mm max

Seals for adjustment (supplied)

4.2 Mounting possibility

On plate:

- Vertical
- Horizontal
- Supply inverter type

5. ELECTRICAL AND MECHANICAL CHARACTERISTICS

Circuit breaker	DPX ³ 630 F/N/H/L
Uninterrupted nominal current I_n (A)	250 - 320 - 400 - 500 - 630
Short time admissible current I_{cw} (kA) (for 0.5s)	5 (up to 400A)
Isolated voltage U_i (V AC)	800
Maximum rated operating voltage U_e (V AC)	690
Rated impulse withstand voltage U_{imp} (kV)	8
Nominal frequency (Hz)	50 - 60
Operating temperature (°C)	-25 ÷ 70
Mechanical endurance (cycles)	20000
Mechanical endurance with motor control (cycles)	10000
Electrical endurance (cycles)	4000
Electrical endurance at 0.5 I_n (cycles)	8000
Category of use	B (up to 400A) and A (for 500A and 630A)
Type of trip	electronic
Electronic trip S1	yes
Electronic trip S2	yes
Electronic trip Sg	yes
Thermal adjustment (I_t)	$(0.4 - 1) \times I_n$
Magnetic adjustment (I_{sm})	$(1.5 \div 10) \times I_t$
Neutral adjustment S1	$(0, 0.5, 1) \times I_t$
Neutral adjustment S2, Sg ⁽¹⁾	$(0, 0.5, 1, 1.5, 2) \times I_t$
Dimensions (W x H x D) (mm)	140 x 260 x 105 (3P) 183 x 260 x 105 (4P)
Weight (kg)	4.5 (3P) - 6.4 (4P)

⁽¹⁾: for 1.5 x I_t and 2 x I_t , regulation must not exceed I_n

5.1 Breaking capacity (kA)

U_e/I_{cu}	Breaking capacity (kA) and I_{cs}			
	F	N	H	L
220/240 V AC	70	100	120	150
380/415 V AC	36	50	70	100
440/460 V AC	30	40	60	70
480/500 V AC	25	30	40	50
600 V AC	20	22	25	28
690 V AC	14	18	20	22
I_{cs} (% I_{cu})	100	100	100	70
Rated making capacity under short circuit I_{cm}				
I_{cm} (kA) at 415V	75.6	105	154	220

5.2 Nominal current (I_n) up to 50°C

I_n (A)	Assigned current trip thermal	
	L1 - L2 - L3	N
	250	250
320	320	0 - 160 - 320 - 480 - 640
400	400	0 - 200 - 400 - 600 - 800
500	500	0 - 250 - 500 - 750 - 1000
630	630	0 - 315 - 630 - 945 - 1260

5.3 Power losses per pole under I_n

I_n (A)	Power losses (W)									
	250		320		400		500		630	
Pole	Phase	Neutral	Phase	Neutral	Phase	Neutral	Phase	Neutral	Phase	Neutral
Cage terminals	7.5	7.5	12.3	12.3	19.2	19.2	22.1	22.1	35.0	35.0
Lugs	7.5	7.5	12.3	12.3	19.2	19.2	22.1	22.1	35.0	35.0
External lugs	8.2	8.2	13.5	13.5	21.1	21.1	25.1	25.1	39.8	39.8
Spreaders	9.0	9.0	14.7	14.7	22.9	22.9	26.7	26.7	42.3	42.3
Rear terminals	8.7	8.7	14.2	14.2	22.3	22.3	26.9	26.9	42.7	42.7
Plug-in version	15.0	15.0	24.7	24.7	38.5	38.5	52.3	52.3	83.0	83.0
Circuit breaker + RCD	10.6	10.6	17.4	17.4	27.2	27.2	34.6	34.6	54.9	54.9

Total power losses has calculated as the sum of losses of every accessory installed

5.4 Functioning in particular conditions

5.4.1 Temperature

°C	Influence of ambient temperature		
	Up to 50	60	70
I_n (A)	250	225	200
	320	288	256
	400	360	320
	500	450	400
	630	567	536

For derating temperature with other configuration, see table A.

5.4.2 Altitude

Altitude (m)	2000	3000	4000	5000
U_e (V)	690	590	520	460
I_n (A)	I_n	$0.98 \times I_n$	$0.93 \times I_n$	$0.9 \times I_n$

5.4.3 Use at 400Hz

Not possible with electronic release.

5.5 ELECTRONIC RELEASES

5.5.1 Version S1 - Adjustment of I_r , I_{sd}

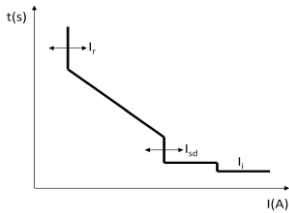
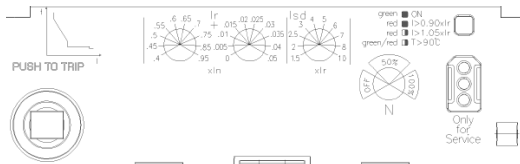

Long delay protection against overloads with an adjustable threshold bases on the RMS value of the current:

- $I_r = 0.4 \div 1 I_n$ (steps 1A)

Short delay protection against short-circuits with an adjustable I_{sd} threshold:

- $I_{sd} = 1.5 - 2 - 2.5 - 3 - 4 - 5 - 6 - 7 - 8 - 9 - 10 \times I_r$ (11 steps)

Instantaneous protection with fixed threshold : $I_i = 5kA$

5.5.2 Version S2 - Adjustment of I_r , T_r , I_{sd} , T_{sd}

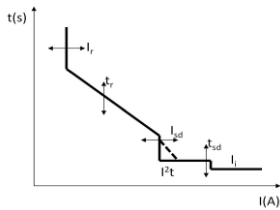
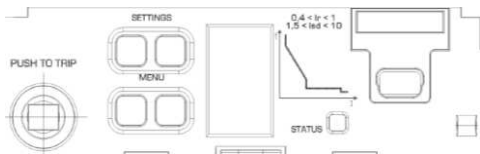

Long delay protection against overloads with an adjustable threshold bases on the RMS value of the current:

- $I_r = 0.4 \div 1 I_n$ (steps 1A)
- $T_r = 3 - 30s$ (3 - 5 - 10 - 15 - 20 - 25 - 30) (7 steps)

Short delay protection against short-circuits with an adjustable I_{sd} threshold:

- $I_{sd} = 1.5 - 2 - 2.5 - 3 - 4 - 5 - 6 - 7 - 8 - 9 - 10 \times I_r$ (11 steps)
- $T_{sd} = 0 - 100 - 200 - 300 - 400 - 500$ ms ($I = K$)
- $T_{sd} = 0 - 100 - 200 - 300 - 400 - 500$ ms ($I^2t = K$)

Instantaneous protection with fixed threshold $I_i = 5kA$

5.5.3 Version Sg – Adjustment of I_r , T_r , I_{sd} , T_{sd} , I_g , T_g

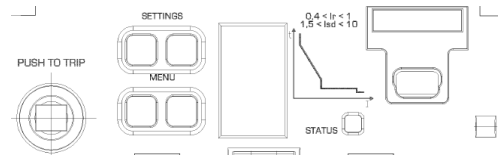

LCD display with adjustment buttons, battery case and USB port.

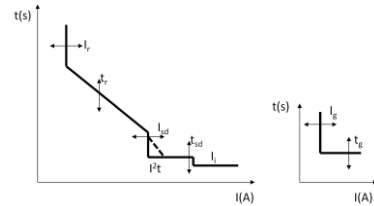

Long delay protection against overloads with an adjustable threshold bases on the RMS value of the current:

- $I_r = 0.4 \div 1 I_n$ (steps 1A)
- $T_r = 3 - 30s$ (3 - 5 - 10 - 15 - 20 - 25 - 30) (7 steps)

Short delay protection against short-circuits with an adjustable I_{sd} threshold :

- $I_{sd} = 1.5 - 2 - 2.5 - 3 - 4 - 5 - 6 - 7 - 8 - 9 - 10 \times I_r$ (11 steps)
- $T_{sd} = 0 - 100 - 200 - 300 - 400 - 500$ ms ($I = K$)
- $T_{sd} = 0 - 100 - 200 - 300 - 400 - 500$ ms ($I^2t = K$)

Instantaneous protection with fixed threshold $I_i = 5kA$

Measure of ground fault:

- $I_g : 0.2 - 0.3 - 0.4 - 0.5 - 0.6 - 0.7 - 0.8 - 0.9 - 1 \times I_n$ (9 steps) and OFF
- $T_g : 0.1 - 0.2 - 0.3 - 0.4 - 0.5 - 1$ s

DPX³ 630

Electronic release

Reference(s) : from 422 056 to 422 215 and
from 422 498 to 422 537

6. CONFORMITY

DPX³ range of product concerning circuit-breakers are in full compliance with the EN/IEC standard 60947-2.

The certificate are issued by LOVAG and/or by IECEE CB-scheme certification scheme.

All the product range are CE, CCC, EAC, ANCE marked.

DPX³ are full in compliance with the Shipping Register of Lloyds, RINA, Bureau Veritas, Germanische Lloyds, Norske Veritas and ABS.

6.1 MARKING

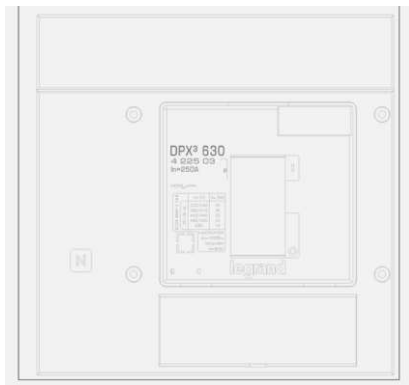

" Tropical climate " :

- execution II (all climates) according to guide UTE C63100

7. EQUIPMENTS AND ACCESSORIES

7.1 Earth leakage modules

Earth leakage characteristics for DPX ³ 630		
	Standard	with Led
Type	A - S	A - S
Uninterrupted nominal current I _n (A)	up to 630	up to 630
Rated isolated voltage U _i (V AC)	500	500
Rated operating voltage U _e (V AC) (50-60Hz)	500	500
Operating voltage (V AC) (50-60Hz)	230 ÷ 500	110 ÷ 500
Nominal frequency (Hz)	50 - 60	50 - 60
Operating temperature (°C)	-25 ÷ 70	-25 ÷ 70
Trip	electronic	electronic
Earth leakage time adjustments (s)	0 - 0.3 - 1 - 3	0 - 0.3 - 1 - 3
Earth leakage breaking capacity I _{dm} (% I _{cu})	60	60
Earth leakage protection adjustments I _{dn} (A)	0.03 ÷ 3	0.03 ÷ 3
Side-by-side mounting	no	no
Underneath mounting	yes	yes
50% Earth fault detection contact I _{dn}	no	yes
Clip on rail DIN 35	no	no
Dimensions (W x H x D) (mm) for 4P	183 x 152 x 105	183 x 152 x 106

(For power losses, see table 5.3)

Standard

400A	3P	ref. 0 260 60
	4P	ref. 0 260 61
630A	3P	ref. 0 260 64
	4P	ref. 0 260 65

LED version

400A	4P	ref. 0 260 63
630A	4P	ref. 0 260 67

7.2 Releases

- shunt releases (Power consumption = 300 VA) with voltage

24 V AC and DC	ref. 4 222 39
48 V AC and DC	ref. 4 222 40
110 V AC and DC	ref. 4 222 41
230 V AC and DC	ref. 4 222 42
400 V AC and DC	ref. 4 222 43
- undervoltage releases (Power consumption = 5 VA) with voltage

24 V DC	ref. 4 222 44
24 V AC	ref. 4 222 45
48 V DC	ref. 4 222 46
110 V AC	ref. 4 222 47
230 V AC	ref. 4 222 48
400 V AC	ref. 4 222 49
- time-lag undervoltage releases (800 ms)

Time-lag modules with voltage	
24 V AC and DC	ref. 0 261 92
230 V AC	ref. 0 261 90
400 V AC	ref. 0 261 91
Universal Release	ref. 4 226 23

7.3 Auxiliary contact

Changeover switch 3A – 250 VAC ref. 4 210 11

To show the state of the contacts or opening of the DPX³ on a fault:

Auxiliary contact (standard) **C**
Fault signal **S**

Auxiliary contact		
Nominal voltage (V _n)	V (AC or DC)	24 to 250
Intensity (A)	24 V DC	5
	48 V DC	1.7
	110 V DC	0.5
	230 V DC	0.25
	110 V AC	4
	230/250 V AC	3

Configurations:

DPX³ 630 → 2 auxiliary contact + 1 fault signal + 1 release

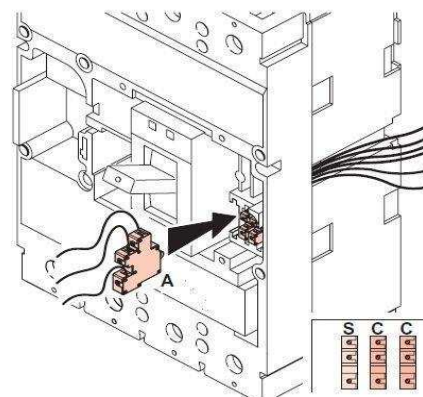

DPX³ 630

Electronic release

Reference(s) : **from 422 056 to 422 215 and**
from 422 498 to 422 537

7.4 Rotary handles

Direct on DPX³

- Standard (black) ref. 0 262 41
- For emergency use (red / yellow) adapting on standard handle ref. 4 222 38

Vari-depth handle IP55

- Standard (black) ref. 0 262 81
- For emergency use (red / yellow) adapting on standard handle ref. 0 262 82

Locking accessories

- Profalux type (cod.HBA90GPS6149) for vari-depth handle ref. 0 262 93
- Ronis type (cod.ABA90GEL6149)for vari-depth handle ref. 0 262 94

7.5 Motor-driven handles

Front operated

- Voltage 24 V AC and DC ref. 0 261 40
- Voltage 48 V AC and DC ref. 0 261 41
- Voltage 230 V AC ref. 0 261 44

Locking accessories

- Ronis type (cod.ABA90GEL6149) ref. 0 261 59
- Profalux type (cod.HBA90GPS6149) ref. 0 261 58

7.6 Mechanical accessories

Insulated shields

- Set of 3 ref. 0 262 30

Sealable terminal shields

- Set of 2 3P ref. 0 262 44
- Set of 2 4P ref. 0 262 45

Terminal covers to guarantee IP20

- Set of 2 3P ref. 4 222 34
- Set of 2 4P ref. 4 222 35

Padlocks

- Accessories to lock in open position ref. 0 262 40

7.7 Connection accessories

Cage terminals

- Set of 4 terminals for cables 300mm² max (rigid) or 240mm² max (flexible) Cu/Al ref. 0 262 50
- Set of 4 terminals for cables 2x240mm² max (rigid) or 2x180mm² max (flexible) Cu/Al ref. 0 262 51

Extended front terminals

- Set of 4 ref. 0 262 47

Spreaders

- Set of 3 (incoming or outgoing 3P) ref. 0 262 48
- Set of 4 (incoming or outgoing 4P) ref. 0 262 49

Rear terminals

(use to connect fixed version with front terminals into fixed version with rear terminals)

- Set of swivel terminals, incoming or outgoing
 - 3P ref. 0 263 50
 - 4P ref. 0 263 51
- Set of flat rear terminals, incoming or outgoing
 - 3P ref. 0 263 52
 - 4P ref. 0 263 53

7.8 Plug-in version

(A plug-in is a DPX³ fitted with tulip contacts mounted on a base)

Terminals for plug-in & draw-out base

- Set of 6 terminals (3P) ref. 4 222 20
- Set of 8 terminals (4P) ref. 4 222 21

Tulip contact

- Set of tulip contact (supplied with an incoming/outgoing protective cover)

3P ref. 0 265 50
4P ref. 0 265 51

Bases

- front terminal mounting base
 - 3P ref. 4 222 22
 - 4P ref. 4 222 23
- flat rear terminal mounting base
 - 3P ref. 4 222 24
 - 4P ref. 4 222 25

Bases with earth leakage underneath mounting

- front terminal mounting base ref. 4 222 26
- Flat rear terminal mounting base ref. 4 222 27

Accessories

- Set of 2 extractor handles ref. 4 222 28
- Set of connectors (6 pins) ref. 0 098 19
- Set of connectors (24 pins – 3x8 or 2x12) ref. 4 222 29
- Signal contact (plugged-in / drawn-out) ref. 0 265 74

7.9 Draw-out version

(A DPX³ draw-out version is a plug-in DPX³ fitted with a "Débro-lift" mechanism which can be used to withdraw the DPX³ while keeping it on its base)

"Débro-lift" mechanism

- For DPX³ base only
 - 3P ref. 4 222 31
 - 4P ref. 4 222 32
- For DPX³ 4P base with earth leakage module ref. 4 222 33

Key lock for "Débro-lift" mechanism

- For DPX³ only
 - Ronis type (cod.ABA90GEL6149) ref. 0 265 76
 - Profalux type (cod.HBA90GPS6149) ref. 0 263 48
- For motorized DPX³ or with rotarv handle
 - Ronis (cod.ABA90GEL6149) ref. 0 265 78
 - Profalux (cod.HBA90GPS6149) ref. 0 265 77

Accessories for "Débro-lift" mechanism

- Isolated handle for drawing-out ref. 0 265 75
- Signal contact (plugged-in / drawn-out) ref. 0 265 74
- Support plate for draw-out version ref. 4 222 36
- Automatic auxiliary contacts (6 pin) for D/O version (2pieces installable max.) ref. 4 222 30

7.10 Supply inverter type

(one plate with interlock for two devices)

- Fixed version ref. 0 264 09
- Plug-in/draw out version ref. 0 264 04

DPX³ 630

Electronic release

Reference(s) : from 422 056 to 422 215 and
from 422 498 to 422 537

7.11 Supply

- Auxiliary supply (input 24 V AC/DC) ref. 4 210 83

7.12 RS485 ModBus communication interface

- To connect electronic DPX³ to an RS485 ModBus communication network ref. 4 210 75

7.13 Web server

- For remote viewing of values collected on electricity meters and multi-function measuring units
 - 32 metering points ref. 0 261 78
 - Unlimited metering points ref. 0 261 79

7.14 Software

- To display values collected on electricity meters and multi-function measuring units on a PC connected to the network
 - 32 metering points ref. 0 261 88
 - Unlimited metering points ref. 0 261 89

7.15 Touch screen

- To show data collected by DX³, DPX³, DMX³, EMDX³. It can manage up to 8 devices ref. 0 261 56

8. CURVES

8.1 TRIPPING CURVE

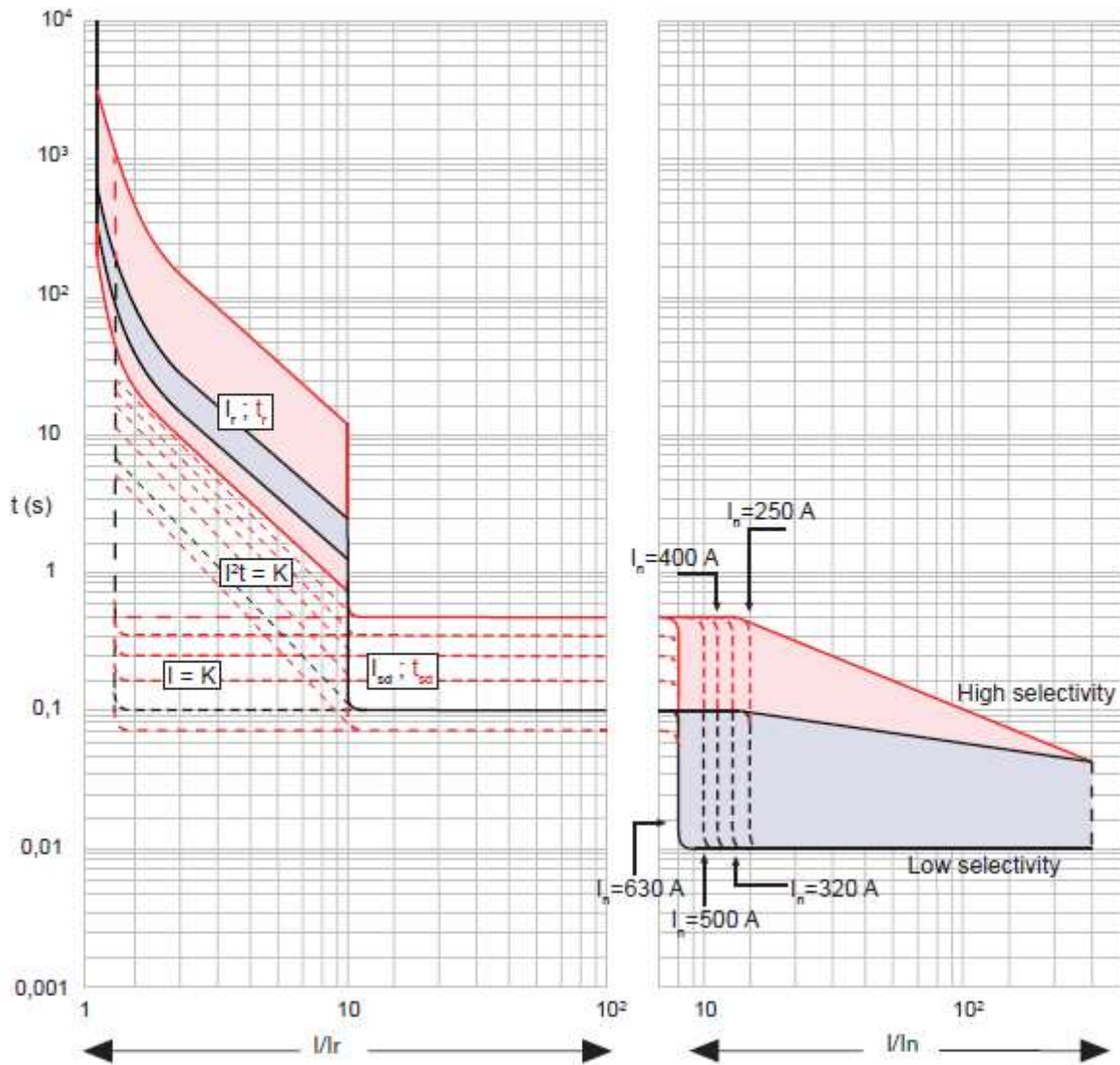

$I_{cu} = 36-50-70-100 \text{ kA}$ $I_{max} = 630 \text{ A}$ 3-4 P $U_o = 415 \text{ Vac}$

Value	Description
t	time
I	current
I_n	rated current
I_r	long time setting current
t_r	long time delay
I_{sd}	short time setting current
t_{sd}	short time delay
$I^2t = K$	Constant pass-through energy setting
$I = K$	Constant tripping time setting
Black area	For S1, S2 and Sg versions
Red Area	Only for S2 and Sg versions

8.1 TRIPPING CURVE (NEXT)

Only Sg version

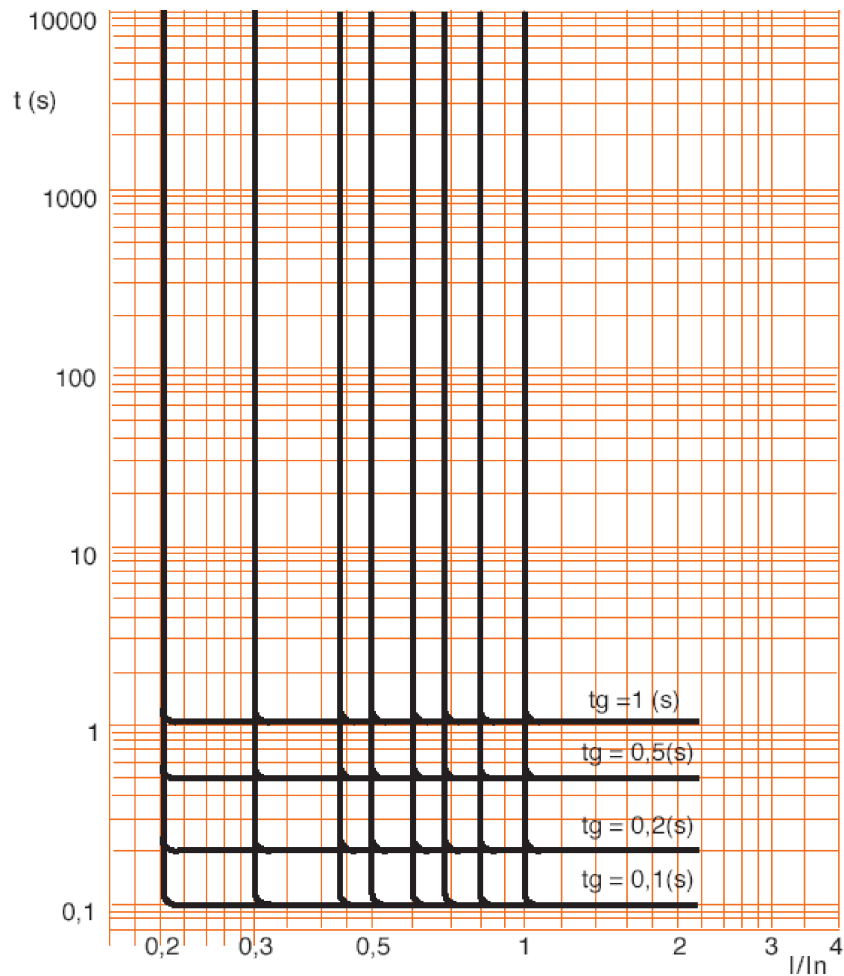

$I_{max} = 630A$ 3-4 P $U_e = 415Vac$

Value	Description
t	time
I	current
I_n	rated current
t_g	Ground fault time delay

8.2 RESTRICTED CURVE IN THERMAL CONSTRAINT

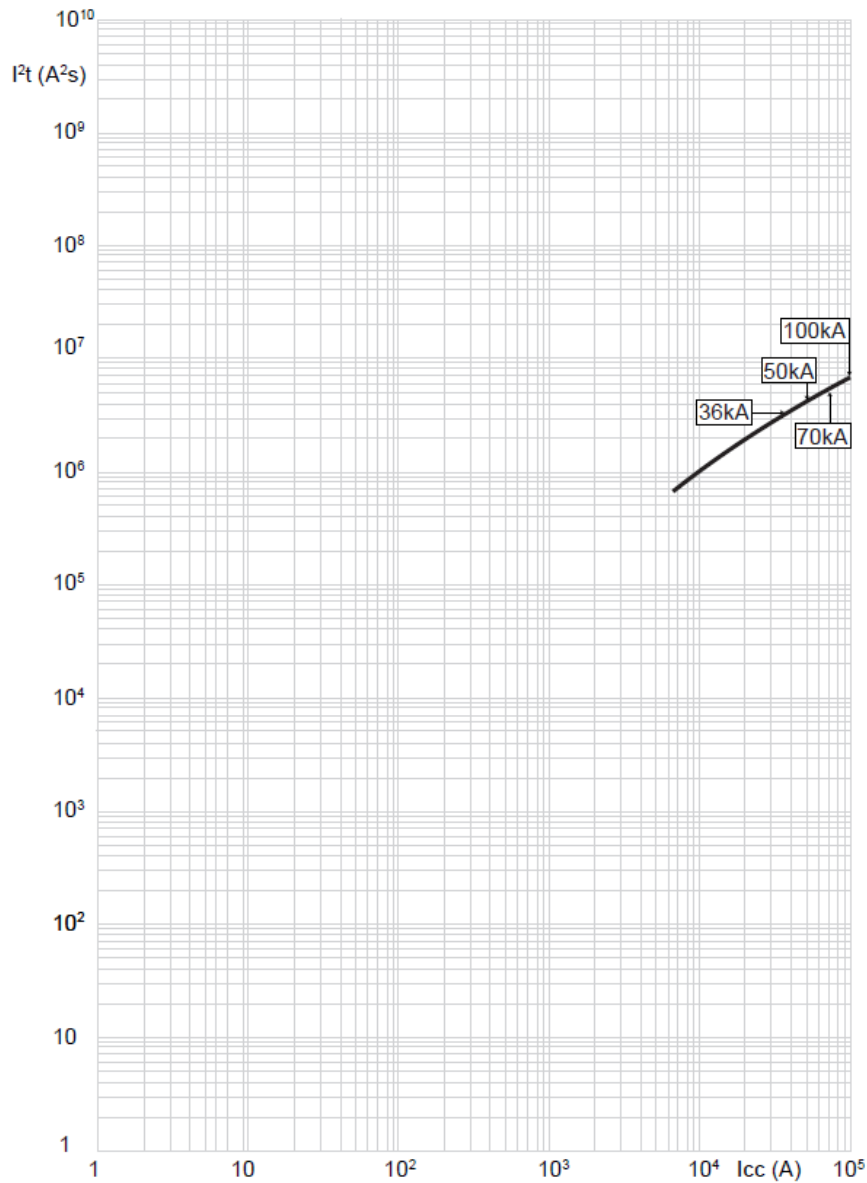

$I_{cu} = 36-50-70-100$ kA $I_{max} = 630A$ 3-4 P $U_o = 415Vac$

Value	Description
I_{cc}	short circuit current
I^2t	pass-through specific energy

8.3 RESTRICTED CURRENT CURVE

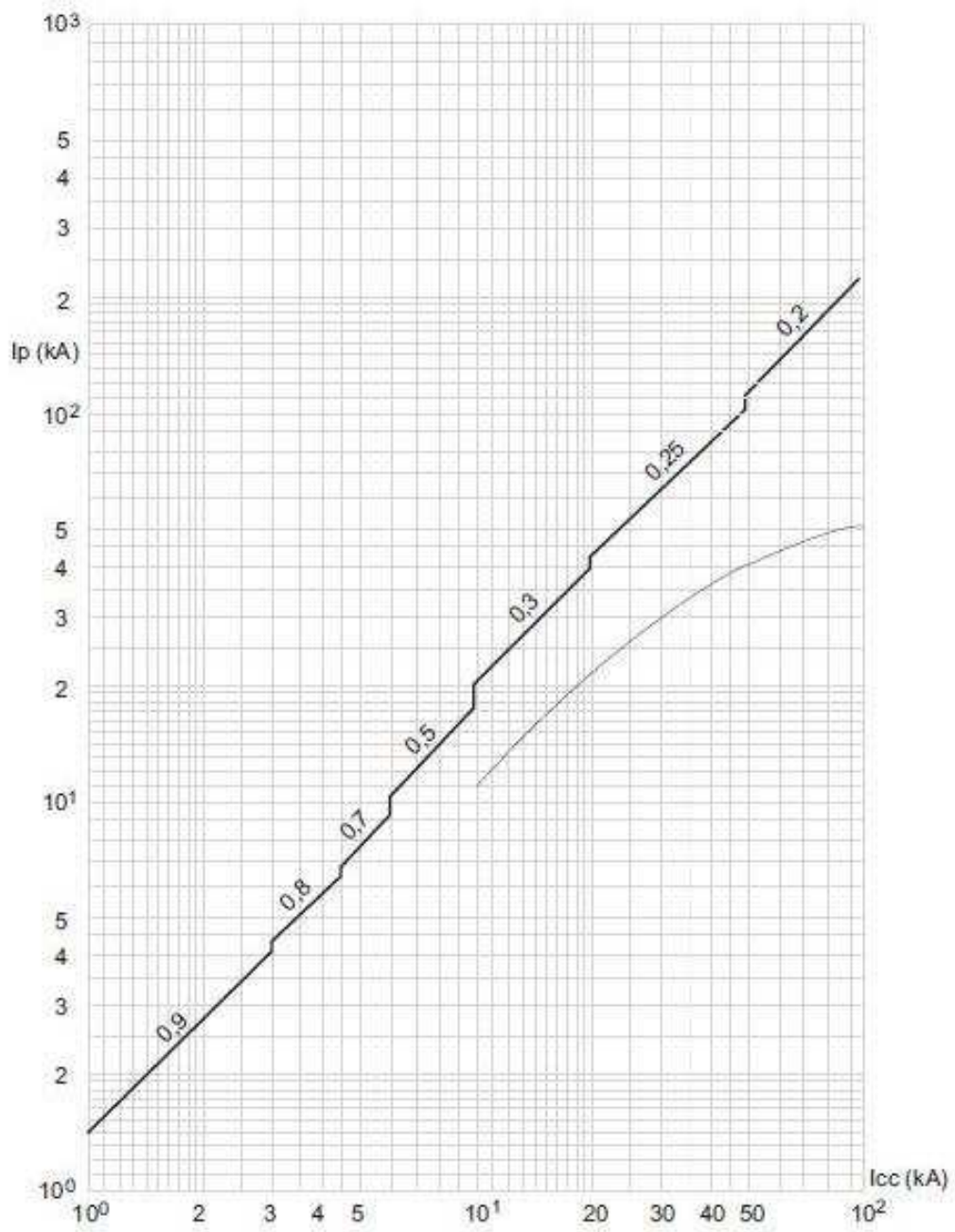

$I_{cu} = 36-50-70-100 \text{ kA}$ $I_{max} = 630A$ 3-4 P $U_e = 415Vac$

Value	Description
I_{cc}	short circuit current
I_p	peak current

DPX³ 630

Electronic release

Reference(s) : from 422 056 to 422 215 and
from 422 498 to 422 537

A) Derating Temperature and configurations

		30°C		40°C		50°C		60°C		70°C	
		I _{max} (A)	I _r / I _n	I _{max} (A)	I _r / I _n	I _{max} (A)	I _r / I _n	I _{max} (A)	I _r / I _n	I _{max} (A)	I _r / I _n
DPX ³ 630 fixed	Cage terminals, flexible cable	630	1	630	1	630	1	599	0.95	567	0.9
	Lugs, flexible cable	630	1	630	1	630	1	567	0.9	536	0.85
	Lugs, rigid cable	630	1	630	1	630	1	599	0.95	567	0.9
	Spreaders, flexible cable	630	1	630	1	630	1	536	0.85	504	0.8
	Rear flat staggered terminals, flexible cable	630	1	630	1	630	1	567	0.9	536	0.85
	Rear tang terminals, flexible cable	630	1	599	0.95	599	0.95	504	0.8	473	0.75
DPX ³ 630 fixed + RCD	Cage terminals, flexible cable + RCD	630	1	630	1	536	0.85	504	0.8	473	0.75
	Lugs, flexible cable + RCD	599	0.95	599	0.95	536	0.85	504	0.8	473	0.75
	Lugs, rigid cable + RCD	630	1	599	0.95	536	0.85	504	0.8	473	0.75
	Spreaders, flexible cable + RCD	630	1	630	1	536	0.85	504	0.8	473	0.75
	Rear flat staggered terminals, flexible cable + RCD	630	1	630	1	536	0.85	504	0.8	473	0.75
	Rear tang terminals, flexible cable + RCD	599	0.95	599	0.95	567	0.9	536	0.85	504	0.8

B) Breaking capacity in DC (kA)

Circuit breaker	I _n (A)	1 pole			2 poles in series			3 poles in series				4 poles in series				Protection		
		≤55-60V	≤110-125V	250V	≤110-125V	250V	400V	≤110-125V	250V	400V	500V	Thermal	Magnetic	Earth leakage				
DPX ³ 630 (I _{cu} = 36kA)	250 - 320 - 400	40	40	36	N/A	N/A	40	N/A	N/A	N/A	40	N/A	1.5 I _n AC	not available				
DPX ³ 630 (I _{cu} = 50kA)	250 - 320 - 400	45	45	40	N/A	N/A	45	N/A	N/A	N/A	45	N/A	1.5 I _n AC	not available				
DPX ³ 630 (I _{cu} = 70kA)	250 - 320 - 400	45	45	40	N/A	N/A	45	N/A	N/A	N/A	45	N/A	1.5 I _n AC	not available				
DPX ³ 630 (I _{cu} = 100kA)	250 - 320 - 400	50	50	45	N/A	N/A	50	N/A	N/A	N/A	50	N/A	1.5 I _n AC	not available				
DPX ³ 630 (I _{cu} = 36kA)	500 - 630	40	40	36	N/A	N/A	40	N/A	N/A	N/A	40	N/A	1.5 I _n AC	not available				
DPX ³ 630 (I _{cu} = 50kA)	500 - 630	45	45	40	N/A	N/A	40	N/A	N/A	N/A	40	N/A	1.5 I _n AC	not available				
DPX ³ 630 (I _{cu} = 70kA)	500 - 630	45	45	40	N/A	N/A	45	N/A	N/A	N/A	45	N/A	1.5 I _n AC	not available				
DPX ³ 630 (I _{cu} = 100kA)	500 - 630	50	50	45	N/A	N/A	50	N/A	N/A	N/A	50	N/A	1.5 I _n AC	not available				

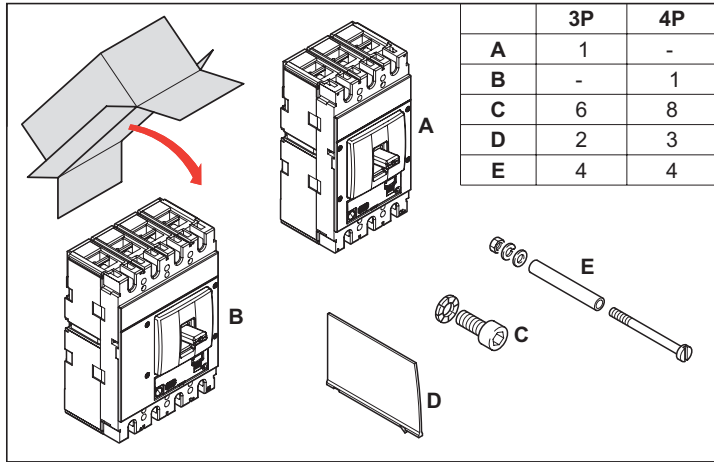

	3P	4P
A	1	-
B	-	1
C	6	8
D	2	3
E	4	4

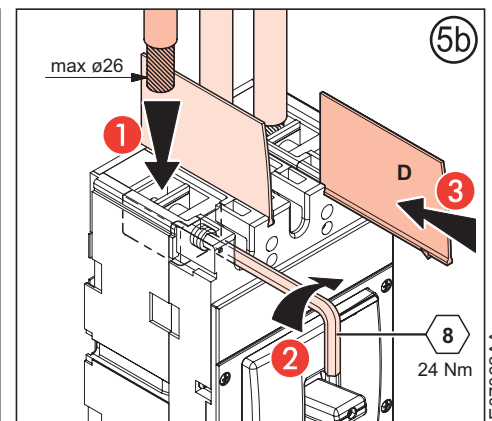
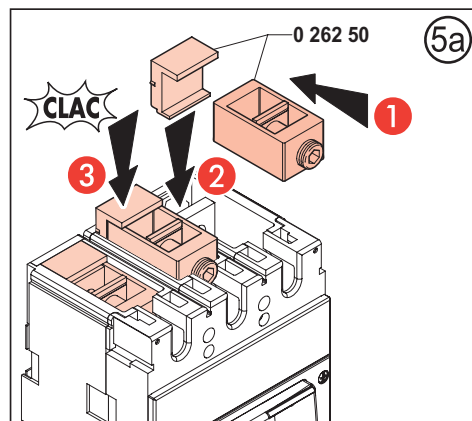
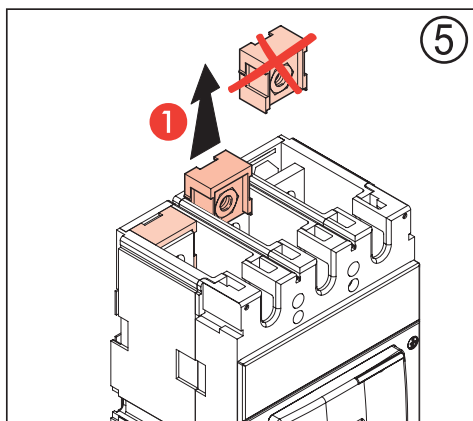
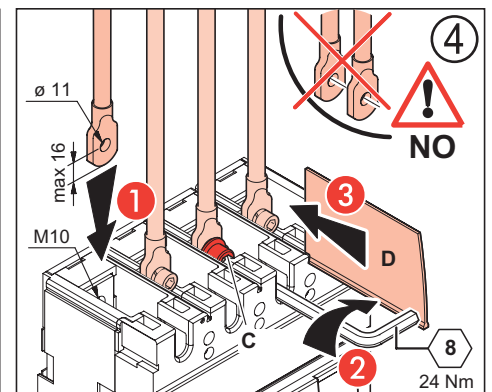
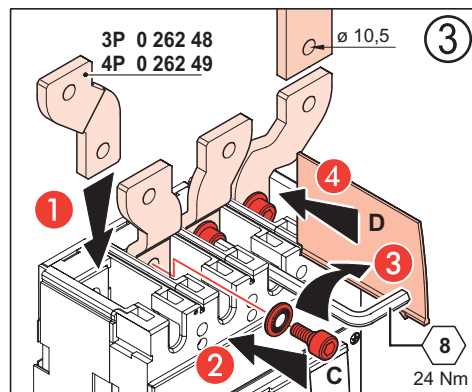
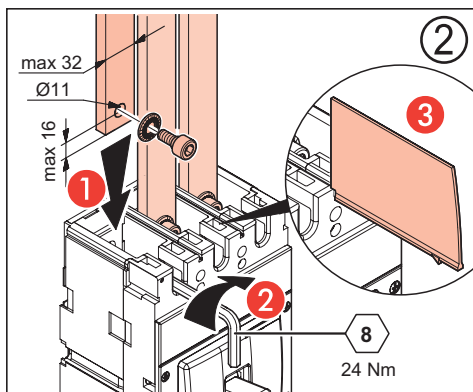
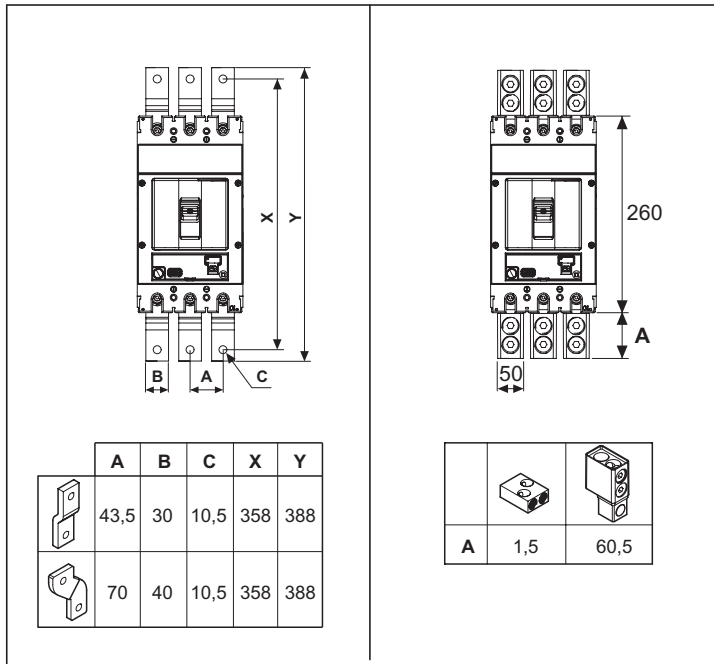
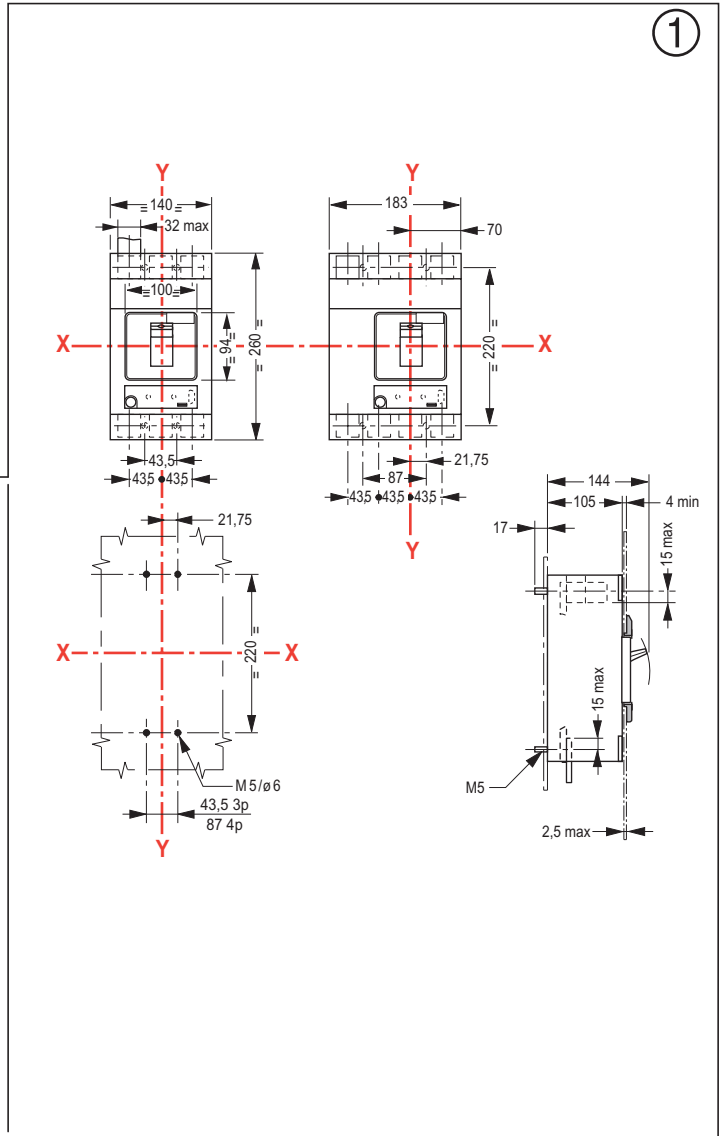

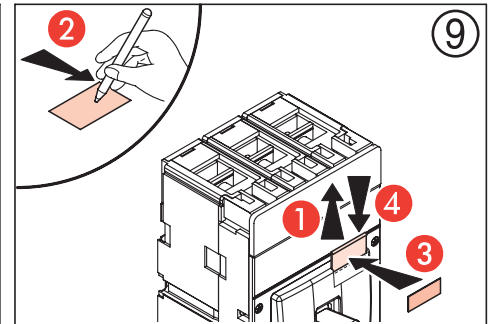
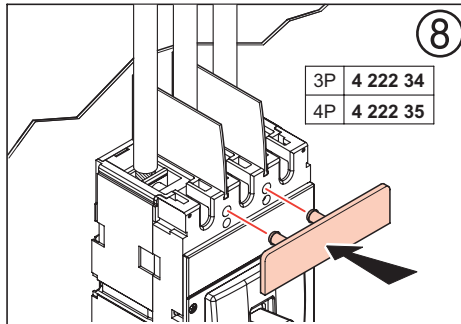
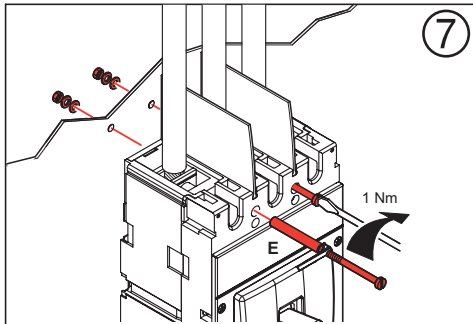
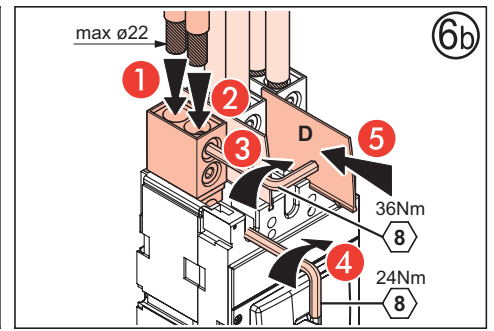
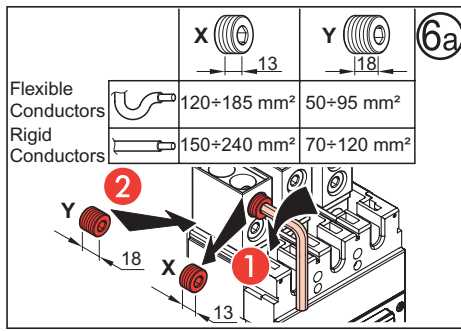
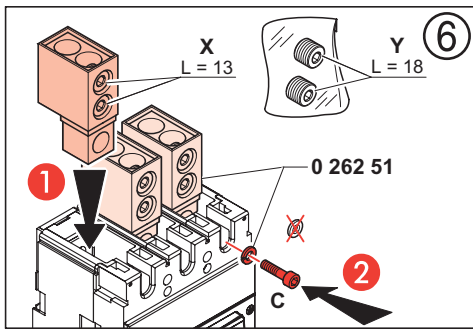

Consignes de s'urt

Ce produit doit être installé conformément aux règles d'installation et de préférence par un électricien qualifié. Une installation et une utilisation incorrectes peuvent entraîner des risques de choc électrique ou d'incendie. Avant d'effectuer l'installation, lire la notice, tenir compte du lieu de montage spécifique au produit. Ne pas ouvrir, démonter, altérer ou modifier l'appareil sauf mention particulière indiquée dans la notice. Tous les produits Legrand doivent exclusivement être ouverts et réparés par du personnel formé et habilité par Legrand. Toute ouverture ou réparation non autorisée annule l'intégralité des responsabilités, droits à remplacement et garanties. Utiliser exclusivement les accessoires de la marque Legrand.

(FR) (BE) (CA) (LU) (CH)



Safety instructions

This product should be installed in compliance with installation rules, preferably by a qualified electrician. Incorrect installation and use can lead to risk of electric shock or fire. Before carrying out the installation, read the instructions and take account of the product's specific mounting location. Do not open up, dismantle, alter or modify the device except where specifically required to do so by the instructions. All Legrand products must be opened and repaired exclusively by personnel trained and approved by Legrand. Any unauthorised opening or repair completely cancels all liabilities and the rights to replacement and guarantees. Use only Legrand brand accessories.

(GB) (CA) (IN) (IE) (US)



Sicherheitshinweise

Dieses Produkt darf nur durch eine Elektro-Fachkraft eingebaut werden. Bei falschem Einbau bzw. Umgang besteht das Risiko eines elektrischen Schlages oder Brandes. Vor der Installation die Anleitung lesen, den produktspezifischen Montageort beachten. Das Gerät vorbehaltlich besonderer, in der Betriebsanleitung angegebener Hinweise nicht öffnen, zerlegen, beschädigen oder abändern. Alle Produkte von Legrand dürfen ausschließlich von durch Legrand geschultes und anerkanntes Personal geöffnet und repariert werden. Durch unbefugte Öffnung oder Reparatur erlöschen alle Haftungs-, Ersatz- und Gewährleistungsansprüche. Ausschließlich Zubehör der Marke Legrand benutzen.

(DE)



Consignas de seguridad

Este producto debe instalarse conforme a las normas de instalación y preferiblemente por un electricista cualificado. Una instalación y una utilización incorrectas pueden entrañar riesgos de choque eléctrico o de incendio. Antes de efectuar la instalación, leer las instrucciones, tener en cuenta el lugar de montaje específico del producto.

No abrir, desmontar, alterar o modificar el aparato salvo que esto se indique específicamente en las instrucciones. Todos los productos Legrand deben ser abiertos y reparados exclusivamente por personal formado y habilitado por Legrand. Cualquiera apertura o reparación no autorizada anula la totalidad de las responsabilidades, derechos a sustitución y garantías. Utilizar exclusivamente los accesorios de la marca Legrand.

(ES) (CL) (CO) (GR) (MX) (PE) (US) (VE)



Istruzioni di sicurezza

Questo prodotto deve essere installato in conformità con le regole d'installazione e di preferenza da un elettricista qualificato. L'eventuale installazione e utilizzo improprio dello stesso possono comportare rischi di shock elettrico o incendio. Prima di procedere all'installazione, leggere attentamente le istruzioni associate e individuare un luogo di montaggio idoneo in funzione del prodotto. Non aprire, smontare, alterare o modificare l'apparecchio eccetto speciale menzione indicata nel manuale. Tutti i prodotti Legrand devono essere esclusivamente aperti e riparati da personale adeguatamente formato e autorizzato da Legrand. Qualsiasi apertura o riparazione non autorizzata comporta l'esclusione di eventuali responsabilità, diritti alla sostituzione e garanzie. Utilizzare esclusivamente accessori a marchio Legrand.

(IT) (CH)



Instruções de segurança

Este produto deve ser instalado de acordo com as regras de instalação e de preferência por um electricista qualificado. A instalação e o uso incorrectos podem provocar riscos de choque eléctrico ou de incêndio. Antes de efectuar a instalação, ler as instruções e ter em conta a localização adequada para a montagem do produto. Não abrir, desmontar, alterar ou modificar o aparelho salvo especificação em contrário nas instruções do produto. Todos os produtos Legrand só devem ser abertos e reparados exclusivamente por pessoal formado e autorizado pela Legrand. Qualquer abertura ou reparação não autorizada cancela todas as responsabilidades, direitos de substituição e garantias. Utilizar exclusivamente os acessórios da marca Legrand.

(PT)



Меры предосторожности

Установка данного изделия должна выполняться в соответствии с правилами монтажа и предпочтительно квалифицированным электриком. Неправильный монтаж или нарушение правил эксплуатации изделия могут привести к возникновению пожара или поражению электрическим током. Перед монтажом необходимо внимательно ознакомиться с данной инструкцией, а также принять во внимание требования к месту установки изделия.

Запрещается вскрывать корпус изделия, а также разбирать, выводить из строя или модифицировать изделие, кроме случаев, оговоренных в инструкции. Вскрытие и ремонт изделий марки Legrand могут выполняться только специалистами, обученными и допущенными к таким работам компанией Legrand. Несанкционированное вскрытие или выполнение ремонтных работ посторонними лицами лишает законной силы любые требования об ответственности, замене или гарантийном обслуживании. При ремонте или гарантийном обслуживании использовать только запасные части марки Legrand.

(RU)



Przepisy bezpieczeństwa

Produkt ten powinien być montowany zgodnie z zasadami instalacji, najlepiej przez wykwalifikowanego elektryka. Niepoprawna instalacja lub złe użytkowanie mogą spowodować ryzyko porażenia prądem lub pożaru. Przed przystąpieniem do instalacji, zapoznać się z instrukcją i uwzględnić miejsce montażu urządzenia.

Nie otwierać, nie demontować ani nie modyfikować urządzenia, jeśli nie ma na ten temat specjalnej wzmianki w instrukcji. Wszystkie produkty Legrand mogą być otwierane i naprawiane wyłącznie przez pracowników przeszkolonych i upoważnionych przez Legrand. Każde otwarcie lub naprawa dokonane bez odpowiedniego upoważnienia zwalnia Legrand od wszelkiej odpowiedzialności, powoduje utratę prawa do wymiany produktu i wygaśnięcie gwarancji. Używać wyłącznie oryginalnych części marki Legrand.

(PL)



Güvenlik talimatları

Bu ürün montaj kurallarına uygun olarak ve tercihen yetkili bir elektrikçi tarafından yerleştirilmelidir. Hatalı bir yerleştirme ve kullanımı, elektrik çarpmasına veya yangına neden olabilir. Yerleştirmeden önce, talimatları okuyun ve ürüne özgü montaj yerine dikkat ediniz. Kılavuzda aksi belirtilmediği sürece cihazı açmayın, sökmez veya üzerinde değişiklik yapmayın. Tüm Legrand ürünlerinin yalnız Legrand tarafından eğitilmiş ve yetkilendirilmiş personel tarafından açılması ve tamir edilmesi gerekir. İzin verilmeyen herhangi bir açılma veya tamir, tüm sorumlulukları, değiştirme haklarını ve garantileri iptal eder. Yalnızca Legrand marka aksesuarları kullanın.

(TR) (CY)



安全说明

该产品应由拥有电工资格的人进行安装。错误的安装和使用会导致发生触电或火灾等危险。











安装前，请仔细阅读安装说明并且考虑产品特殊的安装位置。

除安装说明上特殊要求外，不要随意拆开、拆除以及改动该装置。

所有罗格朗的产品都只能被罗格朗培训并认可的人员拆开和维修。任何未经授权的拆开或维修将被完全取消更换和保证的权利。

DPX³

electrical characteristics

																																					
DEVICES	DPX ³ 160 thermal magnetic				DPX ³ 250 thermal magnetic				DPX ³ 250 electronic release				DPX ³ 630 thermal magnetic				DPX ³ 630 electronic release				DPX ³ 1600 thermal magnetic				DPX ³ 1600 electronic release												
Mounting	On rail  or on plate				On rail  or on plate				On rail  or on plate				On plate				On plate				On plate				On plate												
Breaking capacity (kA) (EN 60947-2 and IEC 60947-2)	16 kA	25 kA	36 kA	50 kA	25 kA	36 kA	50 kA	70 kA	25 kA	36 kA	50 kA	70 kA	36 kA	50 kA	70 kA	100 kA	36 kA	50 kA	70 kA	100 kA	36 kA	50 kA	70 kA	100 kA	36 kA	50 kA	70 kA	100 kA									
380/415 V~	16	25	36	50	25	36	50	70	25	36	50	70	36	50	70	100	36	50	70	100	36	50	70	100	36	50	70	100									
220/240 V~	25	35	50	65	40	60	100	100	40	60	100	100	70	100	120	170	70	100	120	170	70	100	120	170	70	100	120	170									
Breaking capacity (% Icu)	100	100	100	100	100	100	100	100	100	100	100	100	100	100	100	100	100	100	100	100	100	100	100	100	100	100	100	100									
Characteristic of use	50/60 Hz												50/60 Hz																								
Nominal frequency	50/60 Hz												50/60 Hz																								
Maximum rated operating voltage Ue	690 V (500 V with integrated e.l.c.bs)				690 V (500 V with integrated e.l.c.bs)				690 V (500 V with integrated e.l.c.bs)				690 V~				690 V~				690 V~				690 V~												
Category of use	A				A				A				A				A: In 630 A - B: In 200 to 400 A				A				B												
Thermal magnetic adjustment	0,8 to 1 In				0,8 to 1 In				-				0.8 to 1 In				-				0.8 to 1 In				-												
Thermal	0,8 to 1 In				0,8 to 1 In				-				0.8 to 1 In				-				0.8 to 1 In				-												
Magnetic	10 In (400 A for 16 A and 25 A sizes)				5 to 10 In				-				5 to 10 In				-				5 to 10 In				-												
Electronic protection adjustment	-				-				Ir : 0,4 to 1 In I _{sd} : 1,5 to 10 Ir				-				S2 Sg Ir = 0.4 - 1 x In Ir = 3-30 s I _{sd} = 1.5 - 10 Ir tsd (I=K) = 0-500 ms tsd (I≠K) = 0-500 ms I _g = 0.2 - 1 x In I _g = 0.1 - 1 s				-				S2 Sg Ir = 0.4 - 1 x In Ir = 3-30 s I _{sd} = 1.5 - 10 Ir tsd (I=K) = 0-500 ms tsd (I≠K) = 0-500 ms I _g = 0.2 - 1 x In I _g = 0.1 - 1 s												
S2	-				-				-				-				-				-				-												
Sg	-				-				-				-				-				-				-												
Maximum cable cross-section	150 mm ²				150 mm ²				150 mm ²				300 mm ² or 2 x 240 mm ²				300 mm ² or 2 x 240 mm ²				2 or 4 x 240 mm ²				2 or 4 x 240 mm ²												
Rigid cable	150 mm ²				150 mm ²				150 mm ²				300 mm ² or 2 x 240 mm ²				300 mm ² or 2 x 240 mm ²				2 or 4 x 240 mm ²				2 or 4 x 240 mm ²												
Flexible cable	120 mm ²				120 mm ²				120 mm ²				240 mm ² or 2 x 185 mm ²				240 mm ² or 2 x 185 mm ²				2 or 4 x 185 mm ²				2 or 4 x 185 mm ²												
Copper bar and lug width	18 mm				28.5 mm ⁽¹⁾				28.5 mm ⁽¹⁾				32 mm				32 mm				50 mm				50 mm												
Tightening torque	8 Nm				10 Nm				10 Nm				15 Nm				15 Nm				20 Nm				20 Nm												
Nominal current (In) at 40 °C (A)	16	25	40	63	80	100	125	160	100	160	200	250	40	100	160	250	250	320	400	500	630	250	320	400	500	630	500	630	800	1000	1250	500	630	800	1000	1250	1600
In (A)	16	25	40	63	80	100	125	160	100	160	200	250	40	100	160	250	250	320	400	500	630	250	320	400	500	630	500	630	800	1000	1250	500	630	800	1000	1250	1600
Phase	16	25	40	63	80	100	125	160	100	160	200	250	40	100	160	250	250	320	400	500	630	250	320	400	500	630	500	630	800	1000	1250	500	630	800	1000	1250	1600
N	16	25	40	63	80	100	125	160	100	160	200	250	40	100	160	250	250	320	400	500	630	0 - 50 - 100 % of phase value				500	630	800	1000	1250	0 - 50 - 100 % of phase value						
N/2	-	-	-	-	-	-	-	-	-	-	-	-	-	-	-	-	-	250	250	250	320	-				-	-	-	500	630	-						
Magnetic threshold (Im) (A) ⁽²⁾ of DPX ³ thermal magnetic	Fixed				Adjustable				Adjustable				Adjustable																								
In (A)	16	25	40	63	80	100	125	160	100	160	200	250	-	-	-	-	250	320	400	500	630	-				500	630	800	1000	1250	-						
Phase	400	400	400	630	800	1000	1250	1600	125-250	200-400	315-630	500-1000	-	-	-	-	1250-2500	1600-3200	2000-4000	2500-5000	3150-6300	-				2500-5000	3150-6300	4000-8000	5000-10000	6250-12500	-						
N	400	400	400	630	800	1000	1250	1600	125-250	200-400	315-630	500-1000	-	-	-	-	1250-2500	1600-3200	2000-4000	2500-5000	3150-6300	-				2500-5000	3150-6300	4000-8000	5000-10000	6250-12500	-						
N/2	-	-	-	-	-	-	-	-	-	-	-	-	-	-	-	-	-	1000-2000	1250-2500	1600-2500	2000-4000	-				-	-	-	2500-5000	3150-6000	-						
Endurance (cycles)	8000				8000				8000				5000				5000				4000				4000												
Electrical	8000				8000				8000				5000				5000				4000				4000												
Mechanical	25000				20000				20000				10000				20000				10000				10000												
Electronic earth leakage module	without or integrated				without or integrated				without or integrated				downstream e.l.c.bs.				downstream e.l.c.bs.				-				-												
Type	without or integrated				without or integrated				without or integrated				downstream e.l.c.bs.				downstream e.l.c.bs.				-				-												

1: Copper bars only
2: Trip current for 50/60 Hz. For direct current, multiply by 1.5

 For DPX³ magnetic release only, Please, consult us