

P 17 Tempra combined units LV 16 to 63 A

interlocked switched sockets

16-32 A			without rail				with empty Din rail			
<ul style="list-style-type: none"> • IP 44, IP 55, IP 66 according to IEC 60529 and EN 60529 • IK 08 according to IEC 62262 • Conform to IEC 60439-1 • Supplied without cable glands • Self-extinguishing: 650 °C 			125 x 220 mm				125 x 280 mm			
			IP 44		IP 55		IP 44		IP 66	
Pack	Cat.Nos	Pack	Cat.Nos	Pack	Cat.Nos	Pack	Cat.Nos	Pack	Cat.Nos	
200 to 250 V 50/60 Hz	16 A	2P+E	1	0 566 01	1	0 566 21	1	0 566 41	1	0 566 61
	32 A	2P+E	1	0 566 09	1	0 566 29	1	0 566 49	1	0 566 69
380 to 415 V 50/60 Hz	16 A	3P+E	1	0 566 05	1	0 566 25	1	0 566 45	1	0 566 65
		3P+N+E	1	0 566 06	1	0 566 26	1	0 566 46	1	0 566 66
	32 A	3P+E	1	0 566 13	1	0 566 33	1	0 566 53	1	0 566 73
		3P+N+E	1	0 566 14	1	0 566 34	1	0 566 54	1	0 566 74

63 A			with empty Din rail	
<ul style="list-style-type: none"> • IP 66 according to IEC 60529 and EN 60529 • IK 08 according to IEC 62262 • Conform to IEC 60439-1 • Supplied without cable glands • Self-extinguishing: 650 °C 				
			Pack	Cat.Nos
380 to 415 V 50/60 Hz	63 A	3P+E	1	0 589 18
		3P+N+E	1	0 572 99

110 V combined units
Please consult us

Interlocked switched sockets with small flange **p. 342**



P 17 Tempra combined units LV 16 to 63 A

interlocked switched sockets

■ Dimensions

Without rail
LV 16/32 A

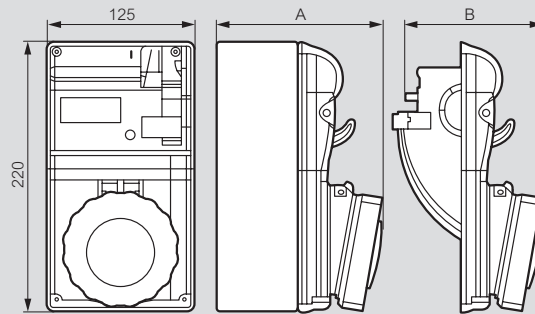

	IP 44 Cat.Nos	Dimensions (mm)		IP 55 Cat.Nos	Dimensions (mm)		
		A	B		A	B	
LV 16 A	2P+E	0 566 01	127	122	0 566 21	133	128
	3P+E	0 566 05	129	124	0 566 25	134	129
	3P+N+E	0 566 06	130	125	0 566 26	135	130
LV 32 A	2P+E	0 566 09	138	133	0 566 29	143	138
	3P+E	0 566 13	138	133	0 566 33	143	138
	3P+N+E	0 566 14	139	134	0 566 34	144	139

With empty Din rail
LV 16/32 A

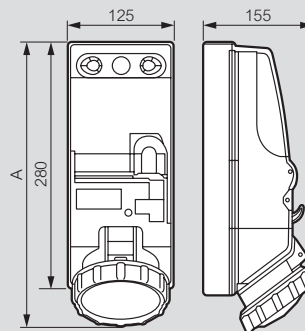

	A	
	IP 44	IP 66
LV 16 A	290	300
LV 32 A	295	310

LV 63 A

Cat.Nos 0 589 18 and 0 572 99

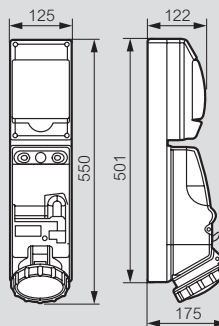

P17 combined units

Cat. Nos: 566 XX - 572 XX - 577 XX - 589 XX

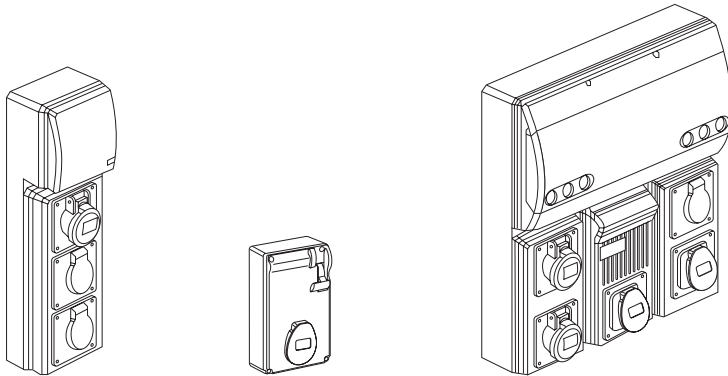

CONTENTS	Page
1. Description	1
2. Use	1
3. Range	1-4
4. Dimensions	4-9
5. Connection	9
6. Technical characteristics	9-10
7. Wiring diagrams	11-15
8. Standards	16
9. Accessories	16

1. DESCRIPTION

- Product for distributing power close to equipment
- Supply of several current types (amps/volts) for industrial and/or domestic pin configuration
- Power supply for one or more devices
- Protection of users and circuits:
 - off-load connection and disconnection provided by units equipped with switched socket with double mechanical interlock
 - protection by MCB, RCBO, RCD (RCCB)
- Material: plastic
- Colour: RAL 7035
- IK08
- IP44, IP55, IP66

2. USE

- Switch with double mechanical interlock:
 - 1st interlock: switch cannot be turned on unless a plug has been inserted
 - 2nd interlock: plug cannot be removed when the switch is on
- Marking of the switch ON and OFF positions
- Transparent window to view protection devices
- Cable entries to be drilled
- Equipped or to be equipped with panel mounting sockets with standard fixing centres (70 x 70)
- Plug-in system: socket can be wired quickly in the cover independently of the box already fixed to the wall

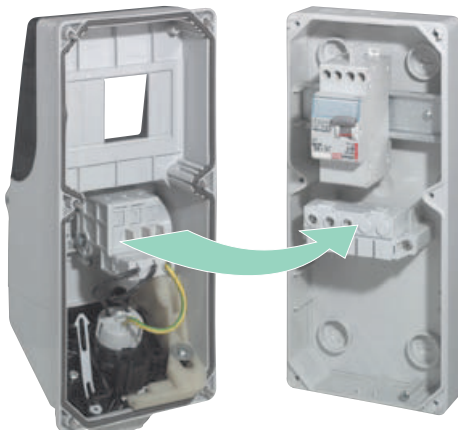

3. RANGE

3.1 Single socket units

- Single socket units with switch (surface and panel mounting version) 16 and 32 A
- Single socket units with switch and rail (surface and panel mounting version) 16 and 32 A
- Single socket unit 63 A

400 W	63 A		Panel mounting socket with switch	Single unit with switch and junction box	Single unit with switch and rail (5 modules)
			3P+E	572 94	572 98
		3P+N+E	572 95	589 10	572 99

- Single ELV combined unit

24 V	16 A	2P	Panel mounting socket without rail with transformer 150 VA	Panel mounting socket with protection device and transformer 160 VA	Surface mounting socket without rail with transformer 150 VA
			589 26	589 25	589 27

3.2 Multi-socket combined units

Combined units with 2 IP44 sockets

Cat. No. 589 20 (can take up to 3 sockets)

External dimensions: W 265 x H 441 mm

12 Lexic modules max.

- 1 x 16 A 2P 24 V faceplate version socket with transformer 150 VA
- 1 x 16 A 2P+E 230 V IP44 socket
- 1 x blanking plate for a third socket
- 1 x 2-pole MCB 6 A (Cat. No. 064 64 or 407 780)
- 1 x 2-pole MCB 16 A (Cat. No. 064 68 or 407 784)
- 1 x 2-pole MCB 32 A (Cat. No 064 61 or 407 777)

Cat. No. 589 21 (can take up to 3 sockets)

External dimensions: W 265 x H 441 mm

12 Lexic modules max.

- 1 x 16 A 2P+E 230 V IP44 socket
- 1 x 32 A 3P+N+E 400 V IP44 socket
- 1 x blanking plate for a third socket
- 1 x 2-pole MCB 16 A (Cat. No. 064 68 or 407 784)
- 1 x 4-pole MCB 32 A (Cat. No. 065 66 or 407 901)

P17 combined units

Cat. No.(s) : 566 XX - 572 XX - 577 XX - 589 XX

3. RANGE (continued)

Cat. No. 589 30

External dimensions: W 125 x H 371 mm
5 Lexic modules max.
2 x 16 A 2P+E 230 V IP44 sockets
1 x 2-pole MCB 20 A (Cat. No. 064 69 or 407 785)

Cat. No. 589 31

External dimensions: W 125 x H 371 mm
5 Lexic modules max.
2 x 16 A 2P+E 250 V domestic pin configuration sockets
1 x 2-pole MCB 20 A (Cat. No. 064 69 or 407 785)

Cat. No. 589 32

External dimensions: W 125 x H 371 mm
5 Lexic modules max.
1 x 16 A 2P+E 230 V IP44 socket
1 x 16 A 3P+E 400 V IP44 socket
1 x 4-pole MCB 20 A (Cat. No. 065 64 or 407 899)

Cat. No. 589 37

External dimensions: W 125 x H 371 mm
5 Lexic modules max.
1 x 16 A 2P+E 230 V IP44 socket
1 x 16 A 2P+E 250 V domestic pin configuration socket
1 x 2-pole MCB 20 A (Cat. No. 064 69 or 407 785)

Combined units with 3 IP44 sockets

Cat. No. 589 33

External dimensions: W 125 x H 421 mm
5 Lexic modules max.
2 x 16 A 2P+E 250 V domestic pin configuration sockets
1 x 16 A 2P+E 230 V IP44 socket
1 x 2-pole MCB 20 A (Cat. No. 064 69 or 407 785)

Cat. No. 589 34 (can take up to 4 sockets)

External dimensions: W 265 x H 441 mm
12 Lexic modules max.
2 x 16 A 2P+E 250 V domestic pin configuration sockets
1 x 16 A 2P+E 230 V IP44 socket
1 x 2-pole MCB 20 A (Cat. No. 064 69 or 407 785)
1 x blanking plate for a fourth socket

Combined unit with 4 IP44 sockets

Cat. No. 589 35 (can take up to 5 sockets)

External dimensions: W 265 x H 501 mm
12 Lexic modules max.
2 x 16 A 2P+E 250 V domestic pin configuration sockets
1 x 16 A 2P+E 230 V IP44 socket
1 x 32 A 3P+E 400 V IP44 socket
1 x 2-pole MCB 20 A (Cat. No. 064 69 or 407 785)
1 x 3-pole MCB 32 A (Cat. No. 064 91 or 407 832)
1 x 4-pole RCCB 63 A (Cat. No. 086 95 or 411 662)
1 x blanking plate for a fifth socket

Cat. No. 589 36 (can take up to 5 sockets)

External dimensions: W 265 x H 501 mm
12 Lexic modules max.
2 x 16 A 2P+E 250 V domestic pin configuration sockets
1 x 16 A 2P+E 230 V IP44 socket
1 x 32 A 3P+N+E 400 V IP44 socket
1 x 2-pole MCB 20 A (Cat. No. 064 69 or 407 785)
1 x 4-pole MCB 32 A (Cat. No. 065 66 or 407 901)
1 x 4-pole RCCB 63 A (Cat. No. 086 95 or 411 662)
1 x blanking plate for a fifth socket

3. RANGE (continued)

Combined units with 5 IP44 sockets

Cat. No. 589 22

External dimensions: W 405 x H 441 mm
18 Lexic modules max.
1 x 16 A 2P 24 V ELV socket
1 x 16 A 2P 24 V ELV socket with transformer 150 VA
1 x 16 A 2P+E 250 V domestic pin configuration socket
1 x 16 A 2P+E 230 V IP44 socket
1 x 16 A 3P+E 400 V IP44 socket
1 x 4-pole RCCB 40 A (Cat. No. 086 94 or 411 661)
1 x 2-pole MCB 6 A (Cat. No. 064 64 or 407 780)
1 x 3-pole MCB 16 A (Cat. No. 064 88 or 407 829)
1 x 2-pole MCB 2 A (Cat. No. 064 61 or 407 777)
1 x 2-pole MCB 20 A (Cat. No. 064 69 or 407 785)

3.3 Multi-socket combined units with faceplates

To be equipped with 16 A sockets with standard fixing centres (70 x 70) only or domestic pin configuration sockets 576 71 and 576 72.

Cat. Nos.	No. of modules	Characteristics	Ext. dim. (HxW)
577 07	5	for 3 x 16 A sockets	421 x 125
577 08	12	for 4 x 16 A sockets	441 x 265
577 09	18	for 6 x 16 A sockets	441 x 405

3.4 Self assembly combined units: bases for junctions

Cat. Nos.	Characteristics	Ext. dim. (HxW)
577 00	for 1 interlocked socket or 1 faceplate 280 x 125	421 x 125
577 01	for 2 interlocked sockets or 2 faceplates 280 x 125	501 x 265
577 02	for 3 interlocked sockets or 3 faceplates 280 x 125	501 x 405

Note: Some Cat. Nos. in this range will only be sold until stocks run out.

3.5 Combined unit for use in refrigerated containers

Cat. No. 657 106

Combined unit 3P+E 32 A 440 V - earth at 3 o'clock - with switch and IP 66/67 socket outlet

Perishable goods are transported in refrigerated containers by road, sea and rail all over the world. The power is supplied by a combined unit designed for use in refrigerated containers by long haulage companies (container terminals, transit areas, railway stations, ports, airports, warehouses, ships, etc.).

Associated mobile products:

Plug: 657 126

Mobile socket: 657 146

Associated fixed product:

Panel mounting socket: 657 116

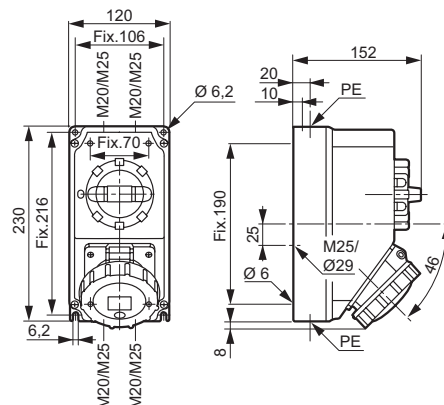

P17 combined units

Cat. Nos.: 566 XX - 572 XX - 577 XX - 589 XX

3. RANGE (continued)



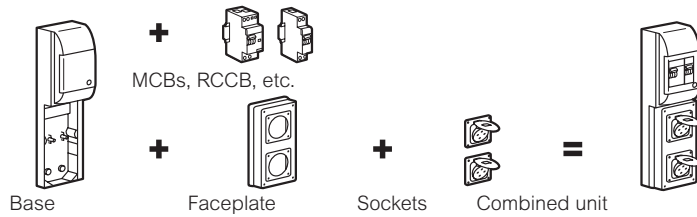

3.5 Self assembly combined units: bases and boxes

Example configuration of a combined unit







COMBINED UNITS HEIGHT 220 MM TO 441 MM

BASES FOR 220 X 125 MM FACEPLATES

Surface mounting box	Base for up to 2 x 16 A sockets	Base for up to 4 x 16 A sockets	Base for up to 6 x 16 A sockets
			
220 x 125 mm ⁽⁵⁾	371 x 125 mm ⁽⁵⁾ 5-module DIN rail	441 x 265 mm ⁽⁵⁾ 13-module DIN rail	441 x 405 mm ⁽⁵⁾ 20-module DIN rail
Pack	Cat. No	Pack	Cat. No
1	0 577 10 ⁽⁷⁾	1	0 589 38 ⁽⁷⁾





Take wall mounting lugs
Cat. No. 0 019 69

220 X 125 MM FACEPLATES

1 x 16 or 32 A socket	2 x 16 A sockets	1 x 63 A socket	Plain plate
			
Pack	Cat. No	Pack	Cat. No
5	0 577 12	5	0 577 13 ⁽²⁾





COMBINED UNITS HEIGHT 280 MM TO 501 MM

BASES FOR 280 X 125 MM FACEPLATES

Surface mounting box	Base for up to 3 x 16 A sockets	Base for up to 6 x 16 A sockets	Base for up to 9 x 16 A sockets
			
280 x 125 mm ⁽⁵⁾	421 x 125 mm ⁽⁵⁾ 5-module DIN rail	501 x 265 mm ⁽⁵⁾ 13-module DIN rail	501 x 405 mm ⁽⁵⁾ 20-module DIN rail
Pack	Cat. No	Pack	Cat. No
3	0 577 11 ⁽⁷⁾	1	0 577 20 ⁽⁷⁾

Take wall mounting lugs
Cat. No. 0 019 69

280 X 125 MM FACEPLATES

2 x 16 A or 32 A sockets	1 x 16 or 32 A socket and 1 x 63 A socket	3 x 16 A sockets ⁽³⁾	Plain plate
			
Pack	Cat. No	Pack	Cat. No
4	0 577 18 ⁽²⁾	2	0 577 19 ⁽²⁾

(1) Can take a key-operated lock Cat. No. 0 577 35 - (2) Supplied with blanking plate

(3) To be mounted horizontally except 16 A domestic pin sockets which must be mounted vertically (IP44 with plug inserted)

(4) IP 54 cover closed - IP 44 connected (5) External dimensions: H x W - (6) For faceplate Cat. No. 0 577 17/19

(7) Can be pole-mounted using kit Cat. No. 0 364 46/47/48/49 (see data sheet in e-catalogue for compatibility) - (8) See 1 + 7 - (9) Wiring required for pilot wire

P17 combined units

Cat. No.(s) : 566 XX - 572 XX - 577 XX - 589 XX

3. RANGE (continued)

3.6 Most common combinations

Possible combinations with bases for 220 x 120 mm faceplates

Bases	Total number of sockets	Possible socket combinations	Choice of faceplate according to socket rating		
			16 A	32 A	63 A
0 577 10 or 0 589 38	1	1 x 16 A or 1 x 32 A or 1 x 63 A	0 577 12	0 577 12	0 577 17
	2	2 x 16 A interlocked socket	0 577 13	-	-
0 577 05	2	2 x 16 A or 2 x 32 A or 2 x 63 A	0 577 12 x 2	0 577 12 x 2	0 577 17 x 2
		1 x 16 A + 1 x 32 A	0 577 12	0 577 12	-
	3	1 x 16 or 32 A + 1 x 63 A	0 577 12	-	0 577 17
		3 x 16 A	0 577 12 + 0 577 13	-	-
		2 x 16 A + 1 x 32 A	0 577 13	0 577 12	-
0 577 06	3	2 x 16 A + 1 x 63 A	0 577 13	-	0 577 17
		4 x 16 A	0 577 13 x 2	-	-
		3 x 16 A or 3 x 32 A or 3 x 63 A	0 577 12 x 3	0 577 12 x 3	0 577 17 x 3
	4	1 x 16 or 32 A + 2 x 63 A	0 577 12	-	0 577 17 x 2
		2 x 16 or 32 A + 1 x 63 A	0 577 12 x 2	-	0 577 17
		2 x 16 A + 1 x 32 A + 1 x 63 A	0 577 13	0 577 12	0 577 17
5	2 x 16 A + 2 x 32 A	0 577 13	0 577 12 x 2	-	
	2 x 16 A + 2 x 63 A	0 577 13	-	0 577 17 x 2	
	4 x 16 A + 1 x 32 A	0 577 13 x 2	0 577 12	-	
6	4 x 16 A + 1 x 63 A	0 577 13 x 2	-	0 577 17	
6	16 A	0 577 13 x 3	-	-	

Possible combinations with bases for 280 x 125 mm faceplates

Bases	Total number of sockets	Possible socket combinations	Choice of faceplate according to socket rating		
			16 A	32 A	63 A
0 577 11 or 0 577 20	2	2 x 16 A or 2 x 32 A	0 577 18	-	-
	3	3 x 16 A	0 577 14	-	-
0 577 03	4	4 x 16 A or 4 x 32 A	0 577 18 x 2	-	-
		2 x 16 or 32 A + 2 x 63 A	0 577 19 x 2	-	-
	5	3 x 16 or 32 A + 1 x 63 A	0 577 18 + 0 577 19	-	-
		3 x 16 A + 1 x 16 or 32 A + 1 x 63 A	0 577 14 + 0 577 19	-	-
0 577 04	6	3 x 16 A + 2 x 16 or 32 A	0 577 14 + 0 577 18	-	-
		6 x 16 A or 32 A	0 577 18 x 3	-	-
		3 x 16 or 32 A + 3 x 63 A	0 577 19 x 3	-	-
	7	5 x 16 or 32 A + 1 x 63 A	0 577 18 x 2 + 0 577 19	-	-
		4 x 16 or 32 A + 2 x 63 A	0 577 18 + 0 577 19 x 2	-	-
		3 x 16 A + 2 x 16 or 32 A + 2 x 63 A	0 577 14 + 0 577 19 x 2	-	-
	8	3 x 16 A + 4 x 16 or 32 A	0 577 14 + 0 577 18 x 2	-	-
		3 x 16 A + 3 x 16 or 32 A + 1 x 63 A	0 577 14 + 0 577 18 + 0 577 19	-	-
	9	6 x 16 A + 1 x 16 or 32 A + 1 x 63 A	0 577 14 x 2 + 0 577 19	-	-
9	6 x 16 A + 2 x 16 or 32 A	0 577 14 x 2 + 0 577 18	-	-	
9	16 A	0 577 14 x 3	-	-	

4. DIMENSIONS

Surface or panel mounting 16/32 A single unit with switch

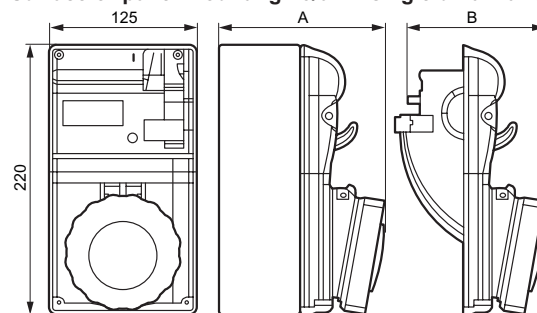

	IP 44 Cat. No.	Dimensions (mm)		IP 55 Cat. No.	Dimensions (mm)		
		A	B		A	B	
LV 16 A	2P+E	566 01	127	122	566 21	133	128
	3P+E	566 05	129	124	566 25	134	129
	3P+N+E	566 06	130	125	566 26	135	130
LV 32 A	2P+E	566 09	138	133	566 29	143	138
	3P+E	566 13	138	133	566 33	143	138
	3P+N+E	566 14	139	134	566 34	144	139

Refer to these dimensions for similar Cat. Nos.

Surface or panel mounting 16/32 A single unit with rail and switch

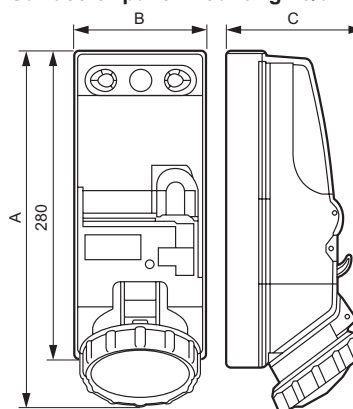

	IP 44 Cat. No.	Dimensions (mm)			IP 55 Cat. No.	Dimensions (mm)			
		A	B	C		A	B	C	
LV 16 A	2P+E	566 40/41	290	125	155	566 60/61	300	125	155
	3P+E	566 45	290	125	155	566 65	300	125	155
	3P+N+E	566 46	290	125	155	566 66	300	125	155
LV 32 A	2P+E	566 49	295	125	155	566 69	310	125	155
	3P+E	566 53	295	125	155	566 73	310	125	155
	3P+N+E	566 54	295	125	155	566 74	310	125	155

Refer to these dimensions for similar Cat. Nos.

Surface mounting 63 A single unit with switch (without rail)

Cat. Nos 572 98/589 10

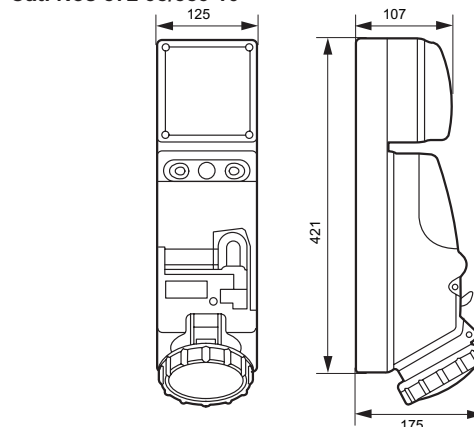

P17 combined units

Cat. No.(s) : 566 XX - 572 XX - 577 XX - 589 XX

4. DIMENSIONS (continued)

Surface mounting 63 A single unit with switch and rail
Cat. Nos. 572 99/589 18

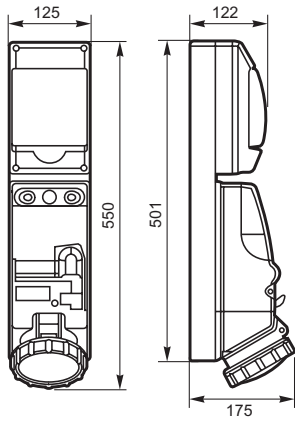

Panel mounting 63 A single unit with switch
Cat. Nos. 572 94/95

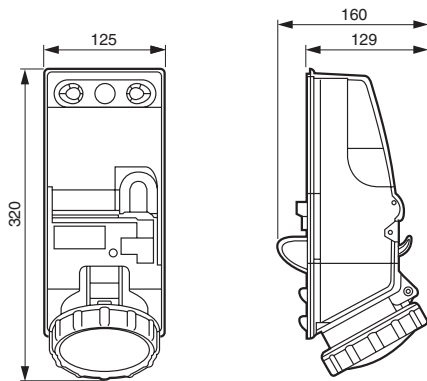

ELV sockets and combined units
Cat. No. 589 25

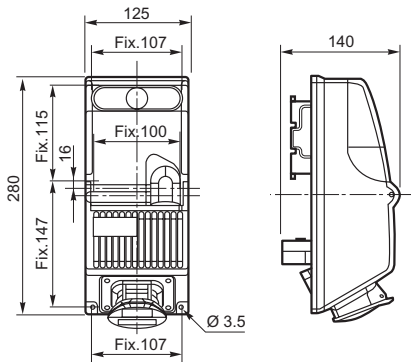

Cat. No. 589 26

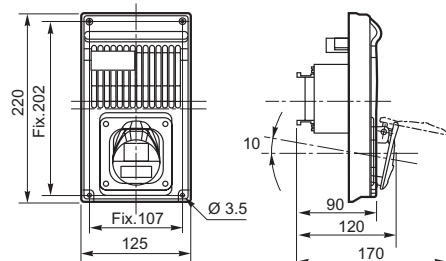

4. DIMENSIONS (continued)

Cat. No. 589 27

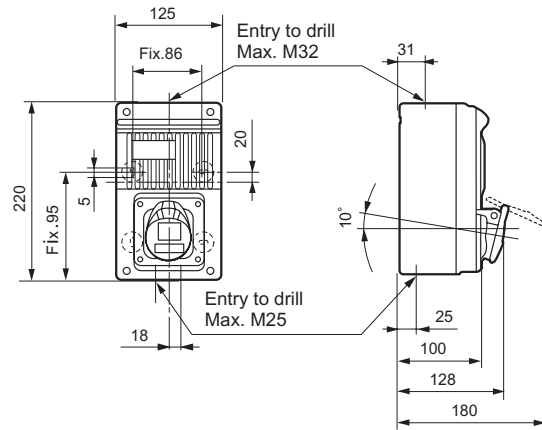

2 sockets with MCB and transformer
Cat. No. 589 20

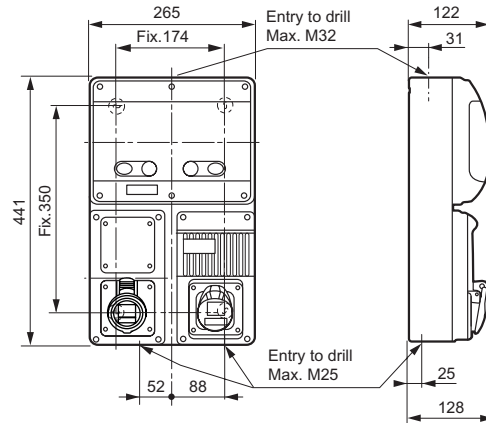

2 sockets with MCB
Cat. No. 589 21

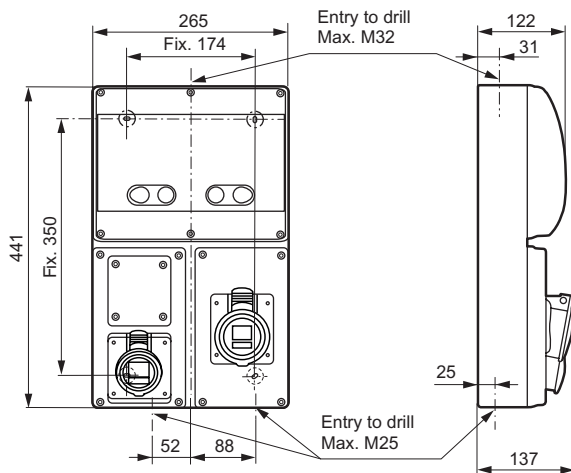

P17 combined units

Cat. No.(s) : 566 XX - 572 XX - 577 XX - 589 XX

4. DIMENSIONS (continued)

5 sockets with MCB + RCCB + transformer

Cat. No. 589 22

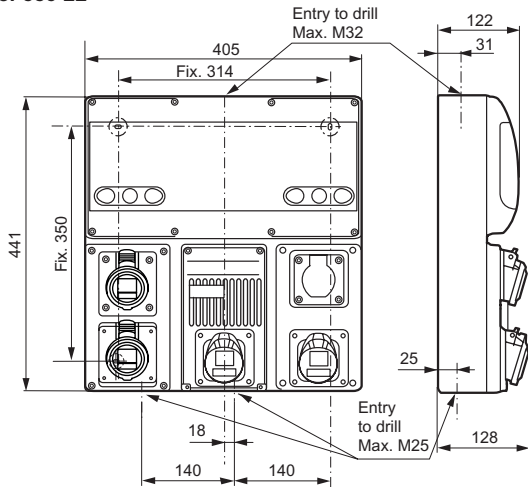

2 sockets with MCB
Cat. Nos. 589 30/32

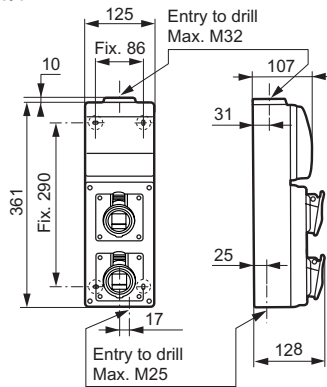

Cat. No. 589 31

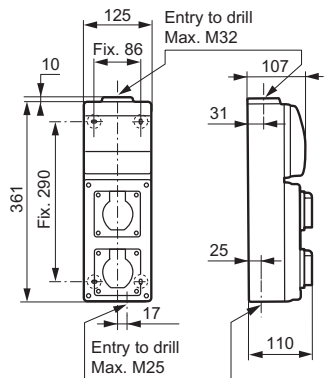

Cat. No. 589 37

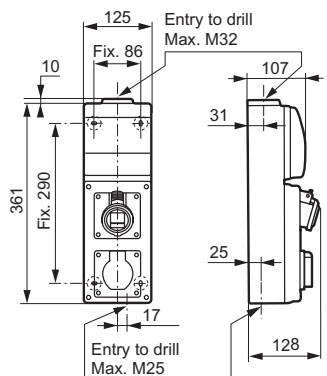

4. DIMENSIONS (continued)

3 sockets with MCB

Cat. No. 589 33

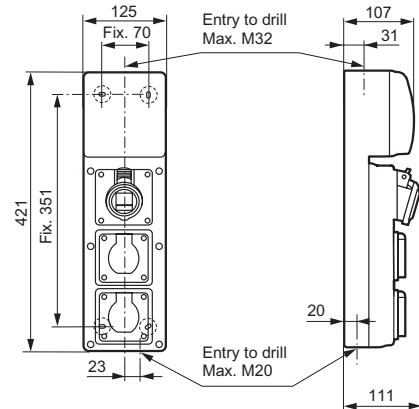

Cat. No. 589 34

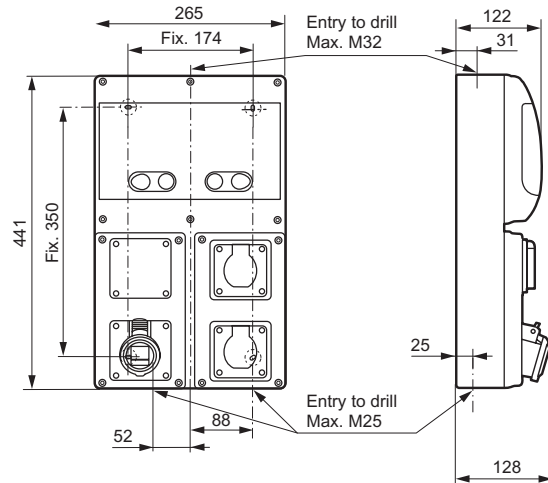

4 sockets with MCB and RCCB

Cat. Nos. 589 35/36

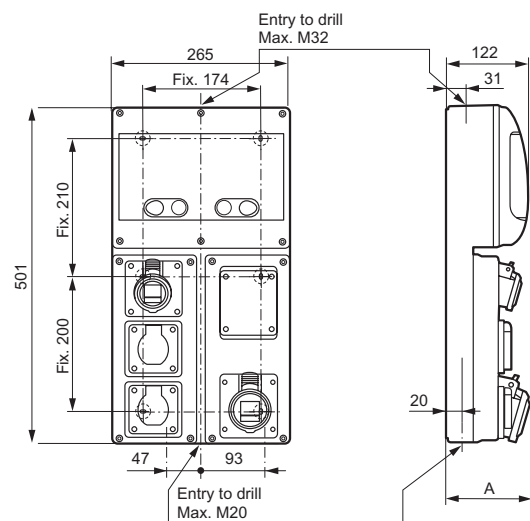

	A
589 35	119
589 36	120

P17 combined units

Cat. No.(s) : 566 XX - 572 XX - 577 XX - 589 XX

4. DIMENSIONS (continued)

Multi-socket combined units equipped with faceplates
Cat. No. 577 07

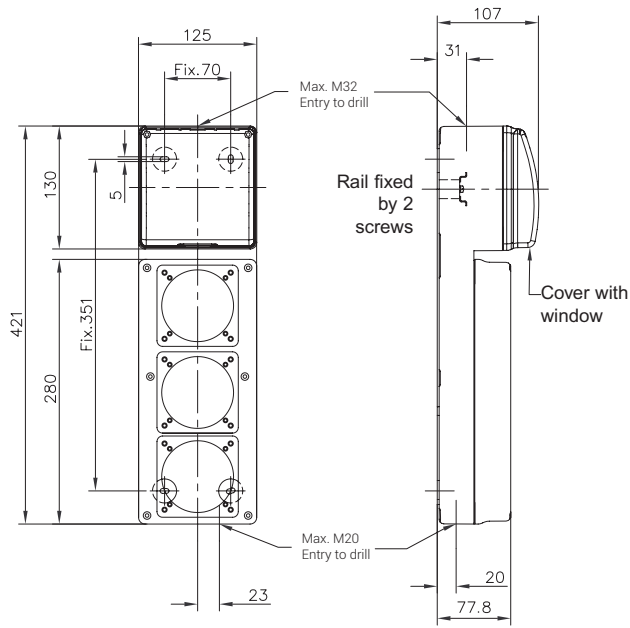

4. DIMENSIONS (continued)

Cat. No. 577 09

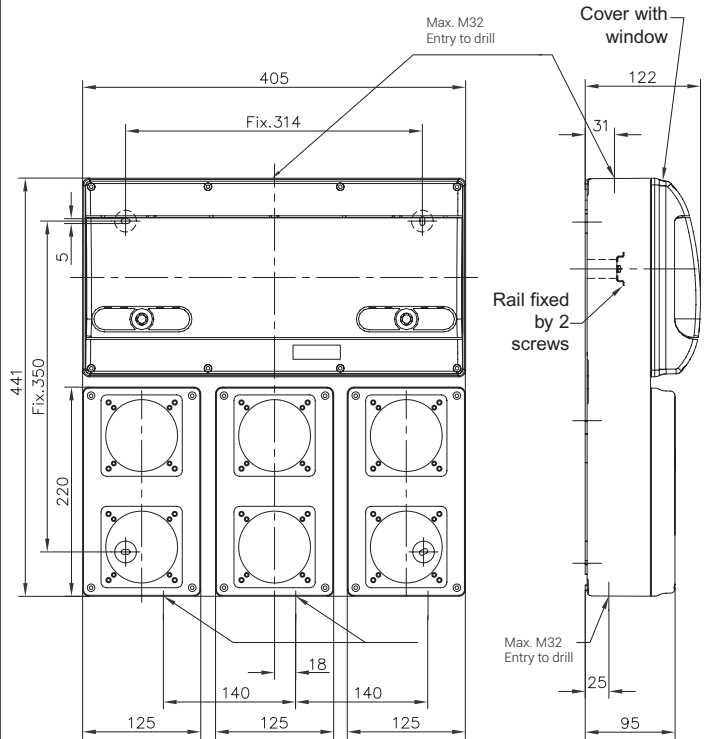

Cat. No. 577 08

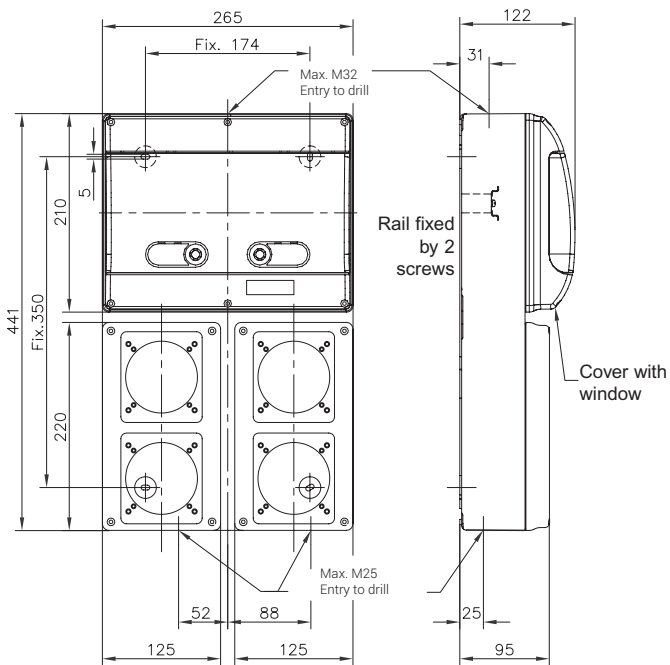

P17 combined units

Cat. No.(s) : 566 XX - 572 XX - 577 XX - 589 XX

4. DIMENSIONS (continued)

Bases

Cat. Nos. 577 01/03

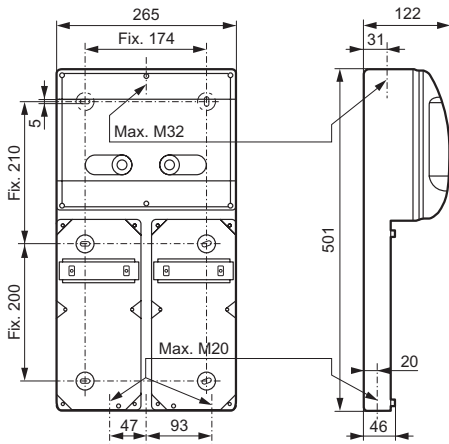

Cat. Nos. 577 02/04

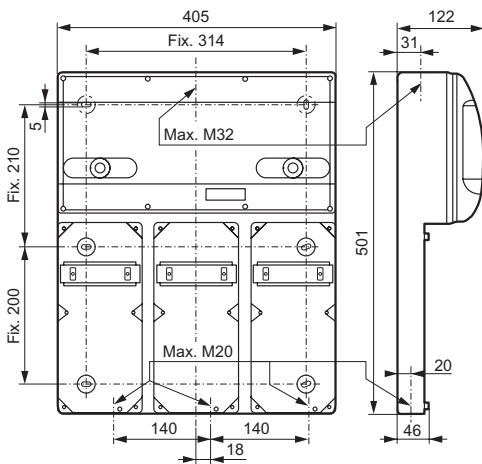

Cat. No. 577 05

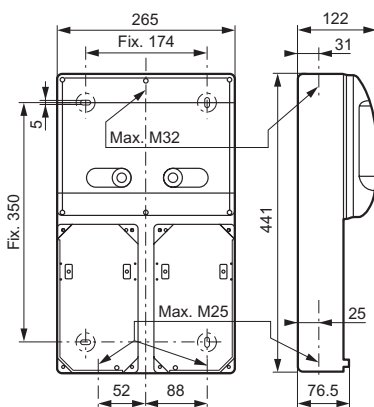

4. DIMENSIONS (continued)

Cat. No. 577 06

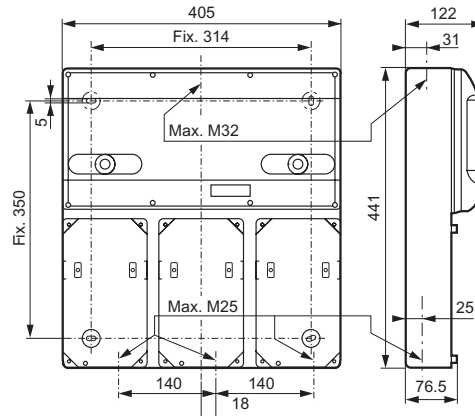

Cat. Nos. 577 00/20

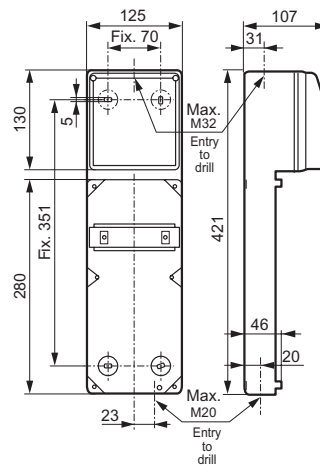

Cat. No. 589 38

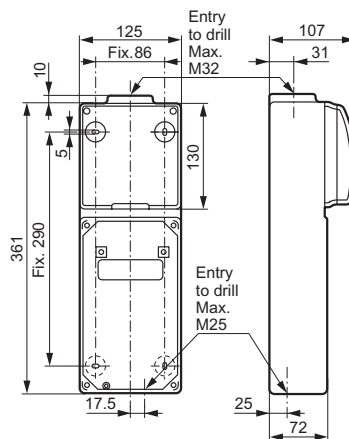

6. TECHNICAL CHARACTERISTICS

6.5 Operating temperatures

- With mechanical interlock only: -20 °C/+100 °C
- With protection (MCB/RCCB): -15 °C/+40 °C

Reminder of circuit breaker derating according to ambient temperature.

A standardised circuit breaker is adjusted to operate at In at an ambient temperature of 30 °C.

The nominal characteristics of this device are modified according to the ambient temperature inside the cabinet or the enclosure where the circuit breaker is located.

In	Ambient temperature/IM					
	-10 °C	0	10 °C	20 °C	30 °C	40 °C
0.5 A	0.6	0.57	0.55	0.52	0.5	0.47
0.8 A	0.96	0.92	0.88	0.84	0.8	0.76
1 A	1.17	1.1	1.07	1.03	1	0.97
2 A	2.34	2.21	2.14	2.06	2	1.94
3 A	3.5	3.36	3.24	3.12	3	2.88
4 A	4.7	4.44	4.28	4.12	4	3.88
6 A	7	6.6	6.4	6.18	6	5.8
8 A	9.6	9.2	8.8	8.4	8	7.6
10 A	11.5	11.1	10.7	10.3	10	9.7
13 A	15	14.3	13.9	13.4	13	12.6
16 A	18.7	18	17.3	16.6	16	15.4
20 A	23.2	22.4	21.6	20.8	20	19.2
25 A	29.5	28.3	27.2	26	25	24
32 A	37.8	36.5	34.9	33.3	32	30.7
40 A	48	46	44	42	40	38
50 A	60	57.5	55	52.5	50	47.5
63 A	75.6	72.5	69.9	66.1	63	59.8

6.6 Resistance to chemical agents

	Housing	Window
Aqueous solutions		
Cold water	++	++
Warm water	+	++
Steam	--	++
5% saline solution	++	++
Oxygenated water	-	++
Water + detergent	+	-
Water + surfactants	+	+
Formic aldehyde	-	++
Alcohols		
Ethanol	+	+
Methanol	+	-
Propanol	++	-
Butanol	++	-
Glycols		
Ethylene glycol	-	+
Phenols	-	-
Cresols	-	-
Bases		
Ammonia	+	-
Sodium hydroxide (caustic soda)	++	-
Sodium hypochlorite (bleach 12°)	++	+
Potassium hydroxide (potash)	++	-
Oxidizing strong acids		
Concentrated acetic acid	+	++

6. TECHNICAL CHARACTERISTICS (continued)

	Housing	Window
Nitric acid 5%	-	++
Sulfuric acid 10%	+	++
Hydrochloric acid 30%	-	+
Perchloric acid 70%	-	+
Hydrofluoric acid 70%	-	++
Chromic acid 50%	+	+
Phosphoric acid 30%	+	+
Weak acids		
Diluted acetic acid < 25%	++	++
Citric acid	++	++
Lactic acid	++	++
Formic acid	-	-
Uric acid	++	+
Animal oils and fats		
Lard	+	-
Butter, cream	++	++
Vegetable oils and fats		
Linseed oil	++	-
Groundnut/olive oil	++	+
Castor oil	++	++
Glycerin	-	-
Mineral oils and fats		
Paraffin (vaseline)	++	++
Engine oil	-	-
Silicone oil	++	++
Cutting oil	+	-
Hydraulic fluid	+	--
Hydrocarbons		
Unleaded petrol	+	-
Diesel oil	+	+
Kerosene	+	+
White spirit	+	-
Chlorinated solvents		
Trichloroethylene	-	--
Trichloroethane	-	-
Perchloroethylene	-	--
Methyl chloride	--	--
Carbon tetrachloride	-	--
Chloroform	--	--
Aromatic solvents		
Benzen	-	-
Toluene	-	-
Xylene	-	-
Aliphatic solvents		
Hexane	-	+
Heptane	-	-
Fluoride solvents		
Trichlorofluoromethane	-	--
Ketones		
Acetone	--	--
Methyl ethyl ketone	--	--
Ethyl acetate	--	--
Terpenes		
Turpentine	-	-

Resistance to chemical agents at ambient temperature according to risk of exposure by spraying

- (++) excellent resistance (continuous exposure)
- (+) good resistance (long-term exposure)
- (-) limited resistance (brief exposure possible)
- (--) poor resistance (exposure to be avoided)

P17 combined units

Cat. No.(s) : 566 XX - 572 XX - 577 XX - 589 XX

7.WIRING DIAGRAMS

Cat. No. 589 20

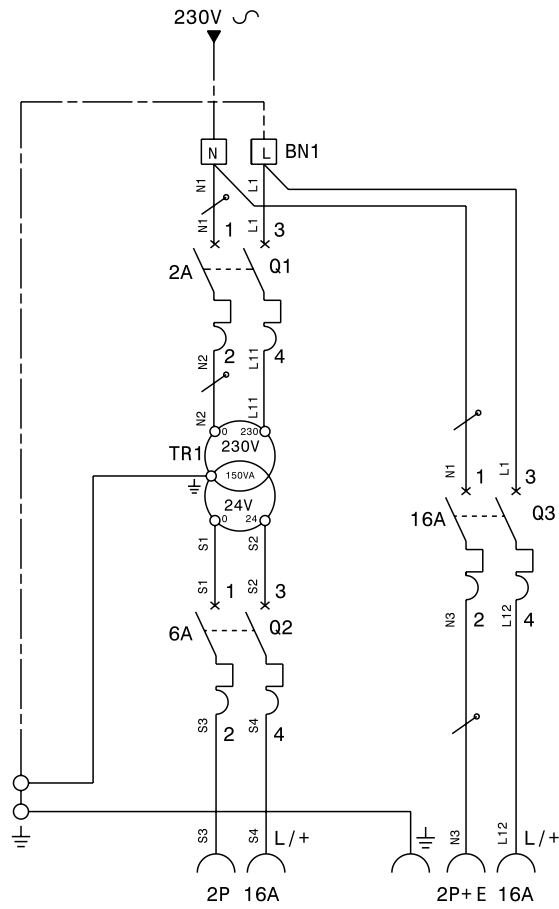

Cat. No. 589 21

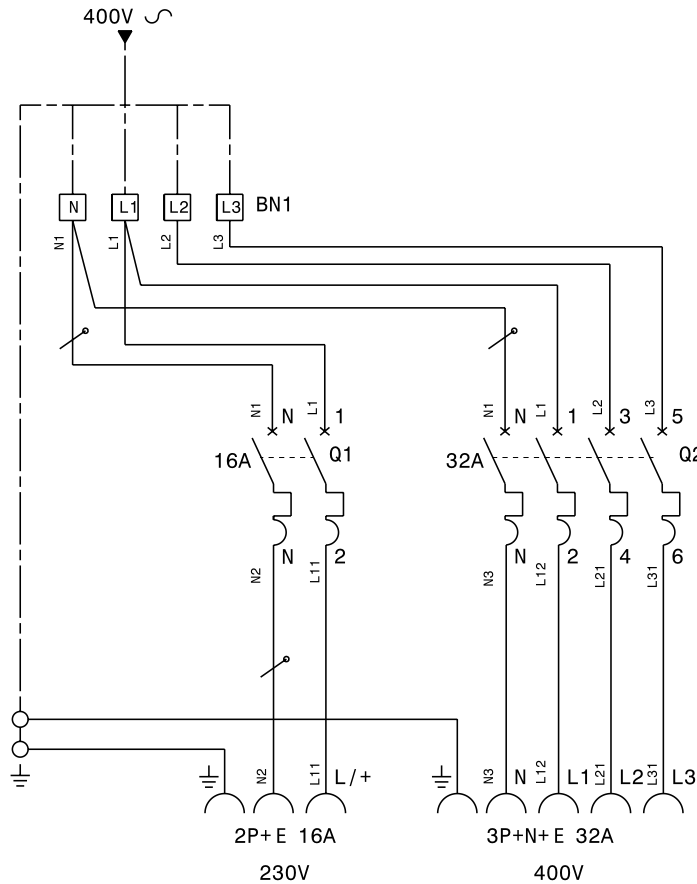

P17 combined units

Cat. No.(s) : 566 XX - 572 XX - 577 XX - 589 XX

7. WIRING DIAGRAMS (continued)

Cat. No. 589 22

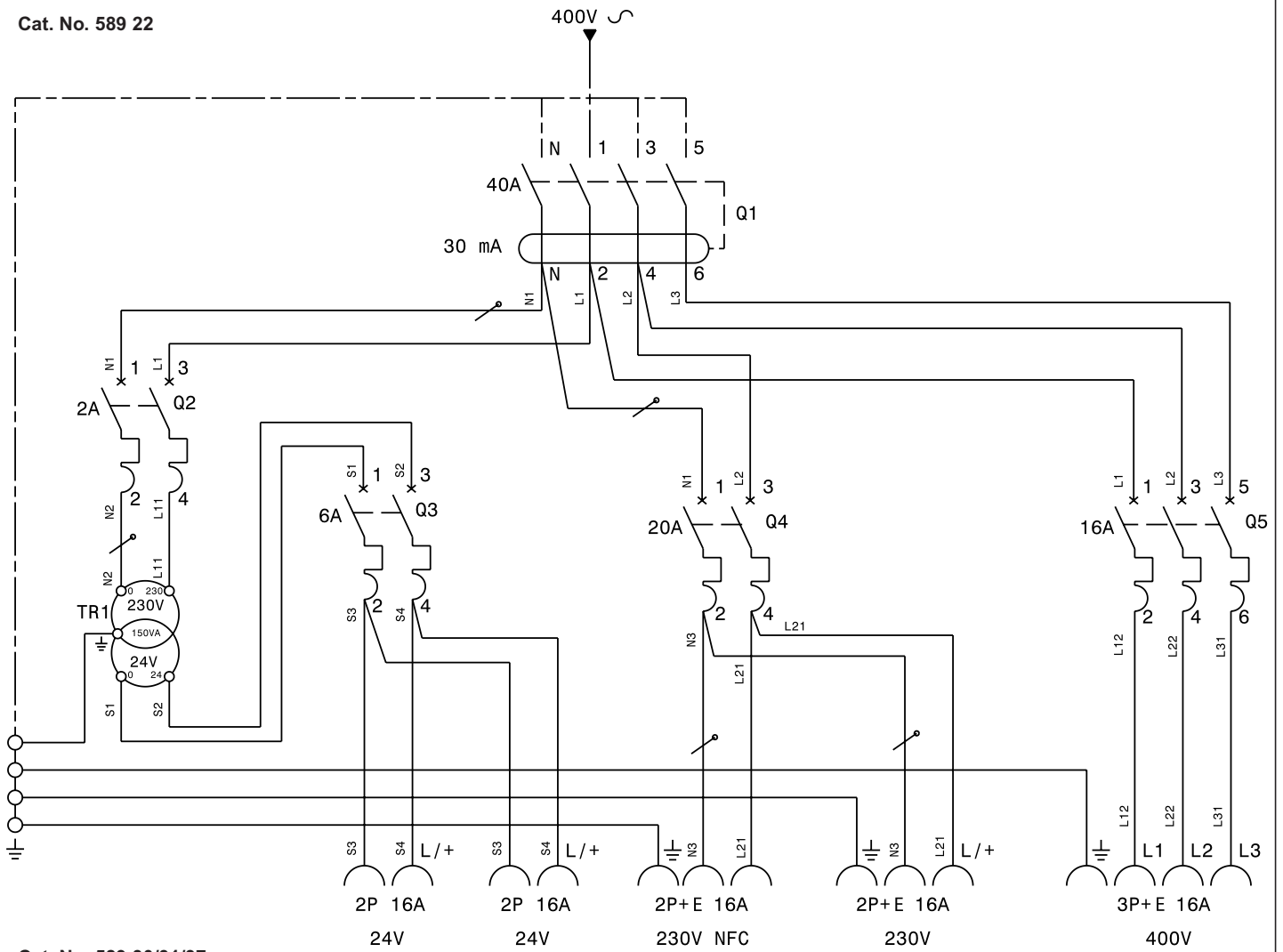

Cat. No. 589 30/31/37

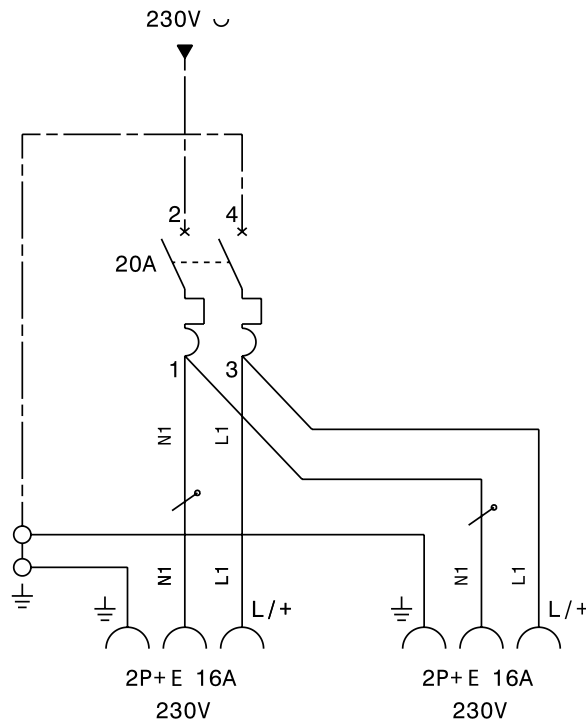

7. WIRING DIAGRAMS (continued)

Cat. No. 589 32

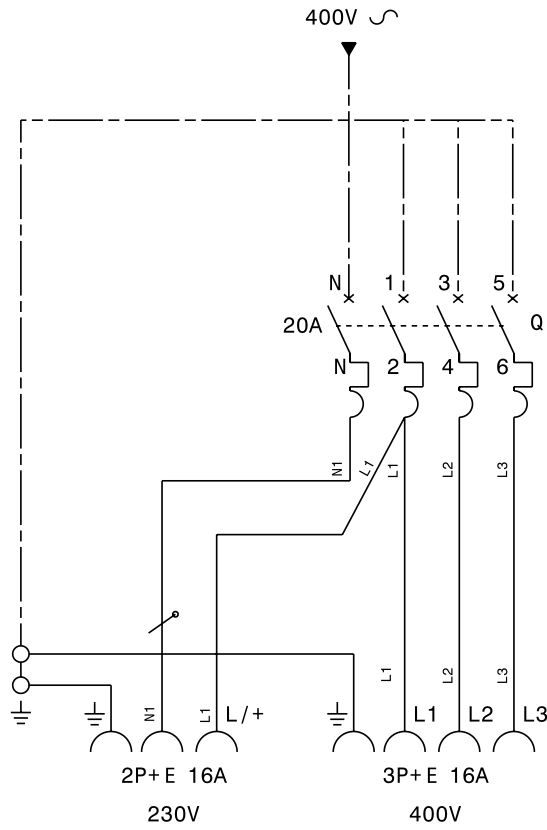

Cat. No. 589 33/34

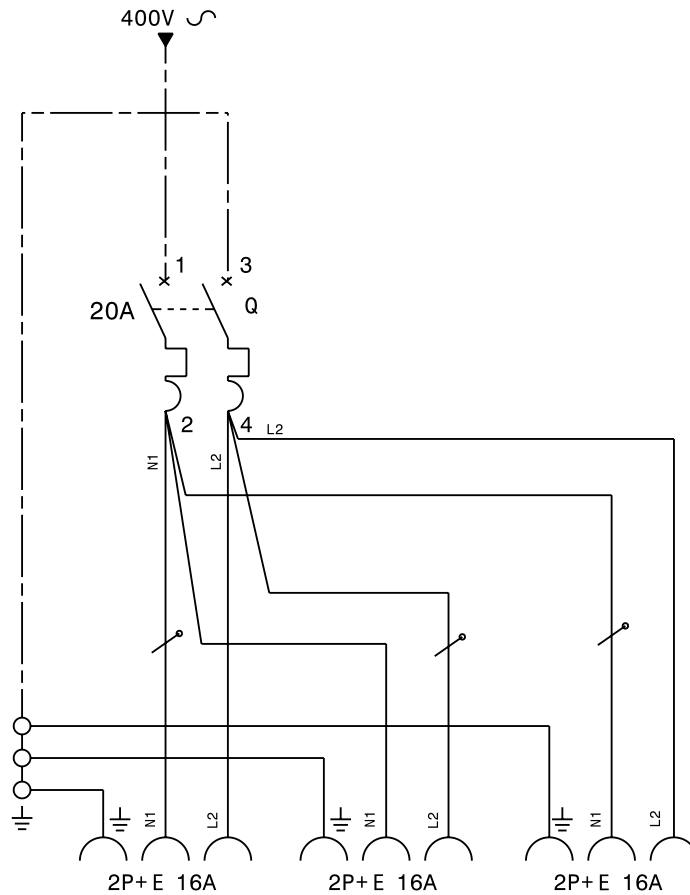

P17 combined units

Cat. No.(s) : 566 XX - 572 XX - 577 XX - 589 XX

7. WIRING DIAGRAMS (continued)

Cat. No. 589 35

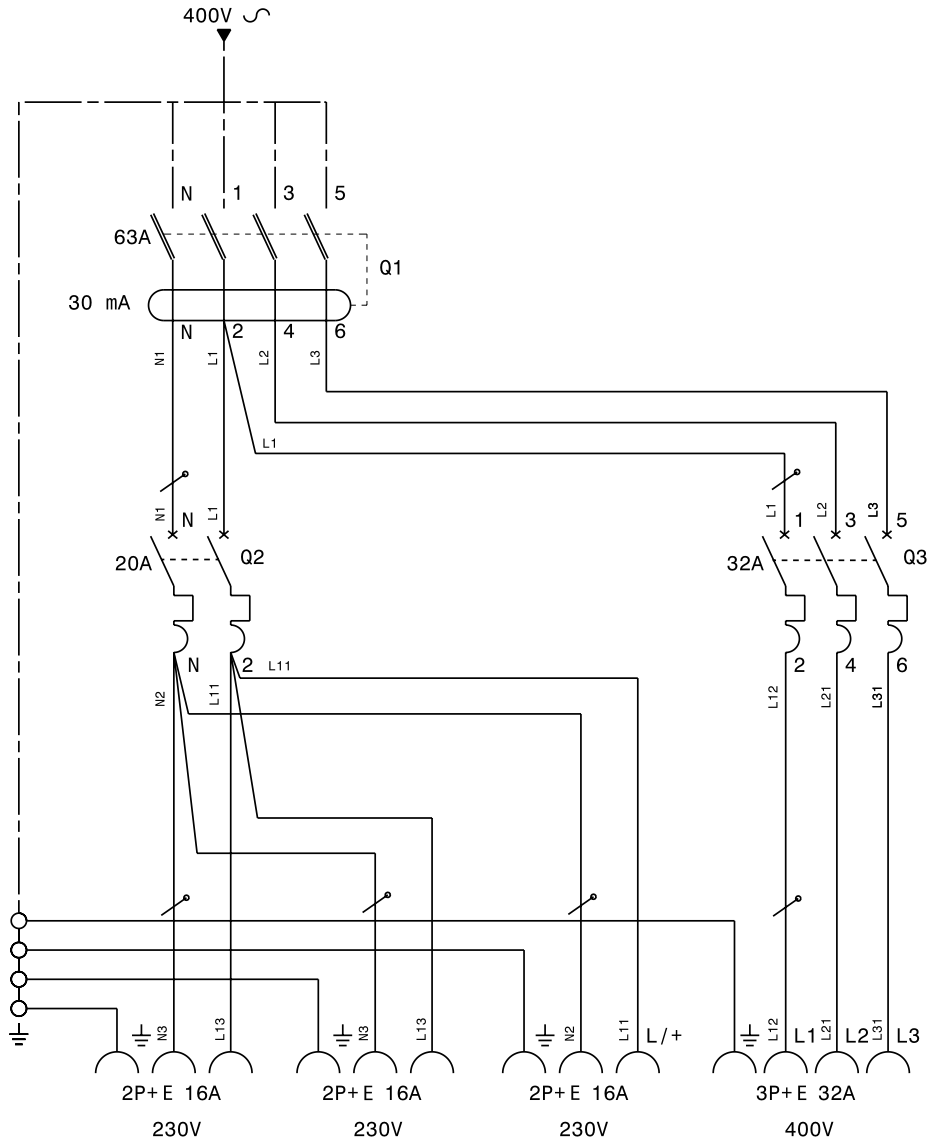

7. WIRING DIAGRAMS (continued)

Cat. No. 589 36

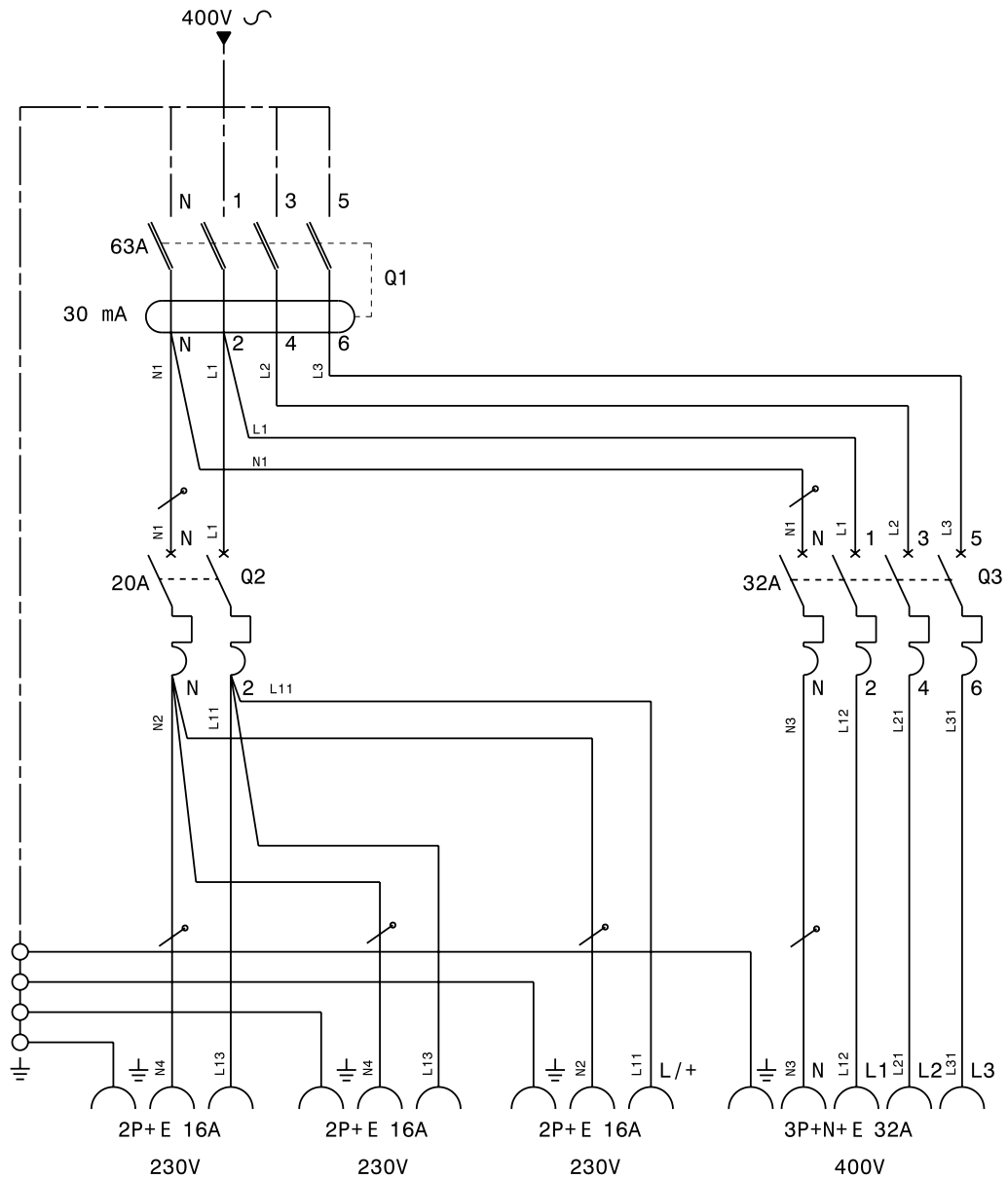

P17 combined units

Cat. No.(s) : 566 XX - 572 XX - 577 XX - 589 XX

8. STANDARDS

- EN 60309-1 and IEC 60309-1
- EN 60309-2 and IEC 60309-2
- EN 60529 and IEC 60529
- EN 62262 and IEC 62262
- EN 60439-1 and IEC 60439-1

9. ACCESSORIES

9.1 Handles



Supplied with lugs to wind the cable for combined unit with:
 5 Lexic modules (577 20/589 33): **Cat. No. 577 37**
 12 Lexic modules: **Cat. No. 577 38**
 18 Lexic modules: **Cat. No. 577 39**

9.2 Key lock

Cat. No. 577 35



For locking the viewing window for optimum safety

9.3 Emergency stop and emergency break

Plates with Osmoz buttons

Osmoz emergency stop button

Cat. No. 577 40

For cutting off the power supply to the units
 Plate fixed on pre-drilled faceplate
 Supplied in parts ready for assembly
 Supplied with push-pull 2 NC contact block

Osmoz emergency break button

Cat. No. 577 45

For cutting off the power supply to the units
 Plate fixed on pre-drilled faceplate
 Supplied in parts ready for assembly
 Supplied with push-pull 1 NO contact block

9.4 IP55 adaptor

Cat. No. 053 948

Takes Mosaic mechanisms
 2 modules (except special surface mounting type)
 No support frame needed



9.5 Wall mounting lug

Cat. No. 001 969

Set of 4 wall mounting lugs
 for 265 and 405 mm combined units
 Vertical and horizontal mounting



9.6 Vertical plate mounting kit

Cat. Nos. 036 446/47/48/49

	36446	36447	36448	36449
57701/03/05	---	---		---
57702/04/06	---	---	---	
57700/10 57711/20 58933		---	---	---
58930/31/32 58937/38		---	---	---
58940/41 58942/43	---		---	---
58950/51/52 58953/54/57	---		---	
59841		---	---	---
59843	---		---	---
59846	---		---	---
58922/34 58935/36 59847/48	---	---		---

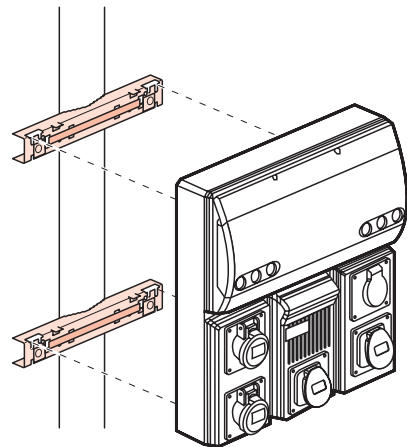

9.7 Tensioner/crimper tool

Cat. No. 036 445

Used for tensioning and crimping the cable sleeve

566 00/01/05/06/09/13/14/20/21/22/26/29/33/34
566 40/41/45/46/49/50/53/54/60/61/63/65/66/69/73/74
572 00/01/05/06/07/08/09/10/11/12/13/14/15/16
572 20/21/22/23/24/25/26/27/28/29/30/31/32/33/34/35/36
572 40/41/42/43/44/45/46/47/48/49/50/52/51/53/54/55/56
572 60/61/62/63/64/65/66/67/68/69/70/71/72/73/74/75/76

